

Salas SSLV1.1 BIB boards guide (DocRev2)

This is a guide of how to tackle the Salas "Back in Black" shunt regulator PCB

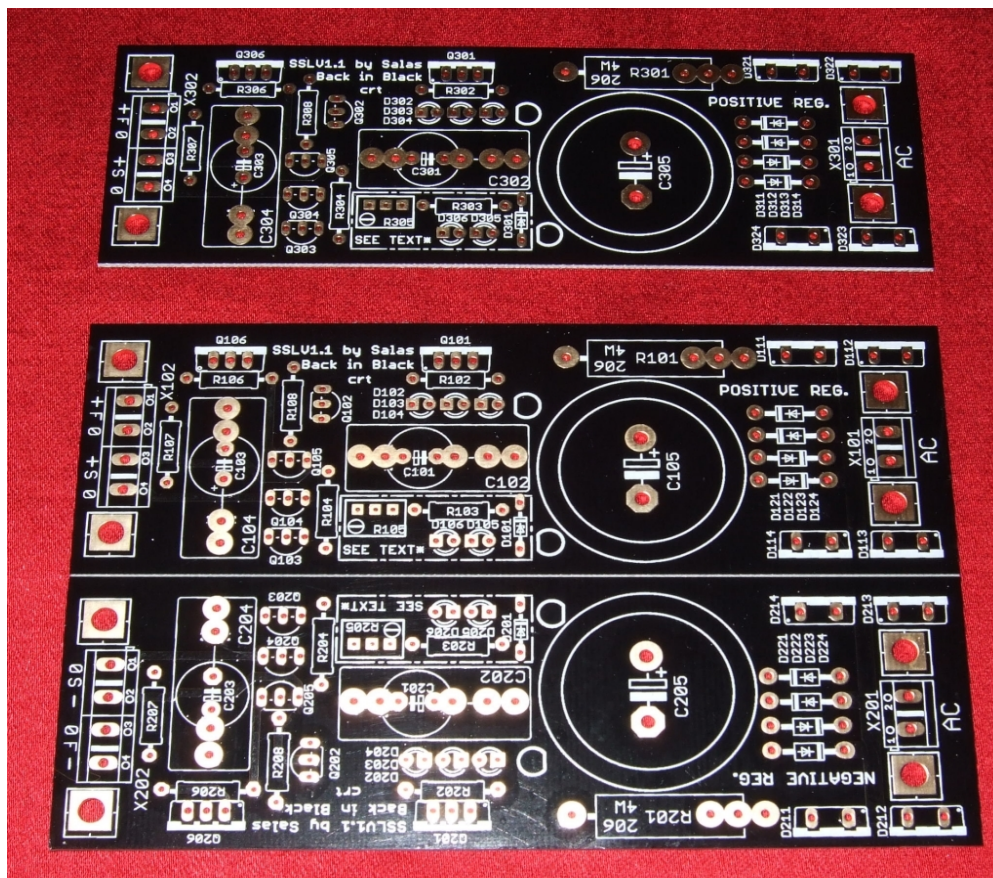

Intro

A shunt regulator is a dynamically corrected DC PSU with all its voltage control elements arranged parallel to its load. There are advantages of very low and relatively even and extended output impedance when using such a PSU. The V1.1BIB regulator is also biased high by a MOSFET CCS (constant current source). That helps insulating it better from the on board preceding rectification and capacitor filter loop. It also imposes no dynamic current changes to that loop. This version belongs to V1 family. It has enhanced performance and options. This type is the most stable and flexible for general use without fixes, much special knowledge or assistance. The performance and adjust are adequate for a range of applications that span from digital source circuits, Wi-Fi audio network DACs, T-Amps, to analogue line level gain circuits, buffers, power amp's voltage amplification stages, MM, and MC phonographic pre-amplifiers.

Remote Sensing

This PCB works on remote sensing 4 wire "Kelvin" outputs. Remote sensing is good for disregarding the wiring resistance issue to correctly measuring the load demands by the regulator's error amplifier and effectively brings the load in touch with the regulator no matter the distance. Keeps the impedance low and gives you freedom of proximity to the circuits and arrangement. The wiring can be manageable gauge that way. Should be twisted pairs which you can twist yourself.

Specs

Three 128x42x1.6mm LWH double layer plated through holes 2 OZ copper boards. 2 positive and 1 negative polarity sections arranged as one 128x126x1.6mm entity with grooved lines between them. Can break apart easily in sections to be used/placed individually or not.

Color: Immersion gold pads on both sides, white graphics & letters, black shiny epoxy boards.

ACV input range: 6.3-36V

DCV output range: 5-45V with Mosfet, 2.5-45V with BJT output

Current draw: 100mA minimum, 1.5A maximum with IRF9610

Output arrangement: 4 wire remote sensing

Voltage drop across regulator: Get a transformer that for DC gives you at least 5V extra from your target voltage. 7-10V is better against mains fluctuations, transformer regulation with high current etc.

Description

There are X10 & X30 for positive polarity, X20 negative polarity sections. X10 & X20 are arranged side by side symmetrically to be used as one non separated +/- polarity regulator if so desired.

*The photographs are from prototypes, little changes may appear on the finals.

Each one has an AC input side, a voltage reference/adjustment middle section, and a 4 wire DC output side. The two TO-220 power semiconductors are arranged along the side edges for access to floor or side mounted heat sinks.

Assembly Instructions

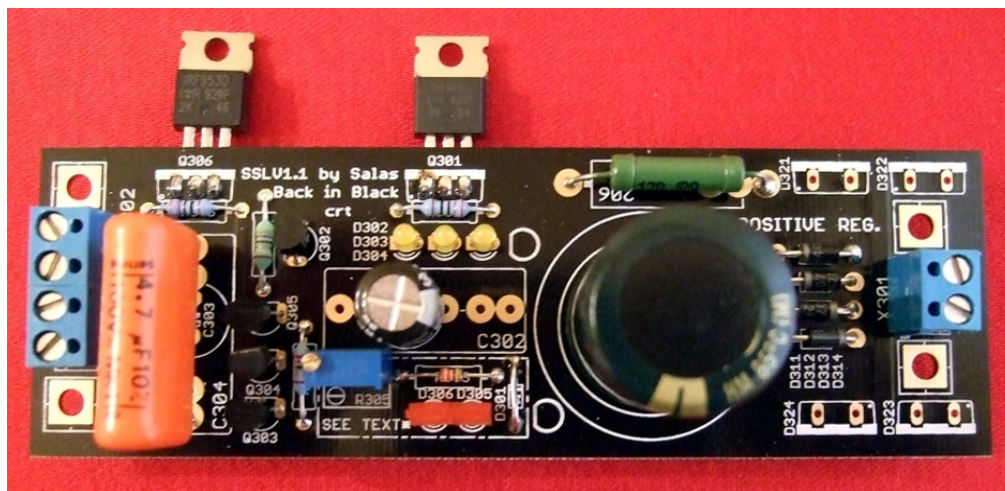

You must know the load needs in DCV and current. According to those you decide the transformer ACV & VA, the voltage reference parts (see appendix 1), and the R101(201,301) current setting value. Its good to spare current in the regulators if you have the sinking surface, it enhances the performance. 70-150mA excess on top of max load demand is usual practice for normal operation. Current setting is governed by the voltage across R101 divided by its value in Ohm. That voltage is the difference of the LEDS forward drop minus the MOSFET VGS curve reading at a given current bias. Higher current sparing and dissipation is allowed by some demanding "hot-rod" users, subjectively preferred. See last page for more explanations on how VGS works and how to project a suitable setting resistor.

You start by populating with the lower profile parts such as resistors, small diodes, TO-92 semis, then you go to taller parts like capacitors, for easy positioning when soldering. There are D symbols for correct LED orientation, the flat side denotes cathode (shorter legs to square pads). After assembly you insulate & sink the power semiconductors, you wire* a dummy load resistor on output, and you connect a Volt meter to it. Lastly you attach the AC secondary of a fused mains transformer to spec. You set any trimmer half quarter left. After power-on all LEDs should be lit, there must be some voltage showing on the meter, wait a little for the Vref filter capacitor to charge and voltage to stop climbing to it (if with Ecap), then you turn the trimmer to achieve nominal voltage output. You check for 10 minutes that nothing is overheating, and you tweak the trimmer for compensating any voltage drift due to have reached cruising temperature by then. If OK, go power your target circuit.

***IMPORTANT:** These are 4 wire output ONLY remote load sensing circuits. You must use 2 wires from +F, +S and two wires from F0,S0 points shown on board. Or F-, S- & OS, OF on negative polarity. The +F, +S wires meet at +V side of a load circuit, the F0, S0 at ground side. F-, S- meet at the -V side of a load circuit, the OS, OF at ground side. With a test dummy resistor floating load the sides have no meaning as long as the wires meet correctly same side as pairs described. If the wiring misses a pair or its done wrong, there can be damage to the regulators. Be sure that the connector's screws are tight.

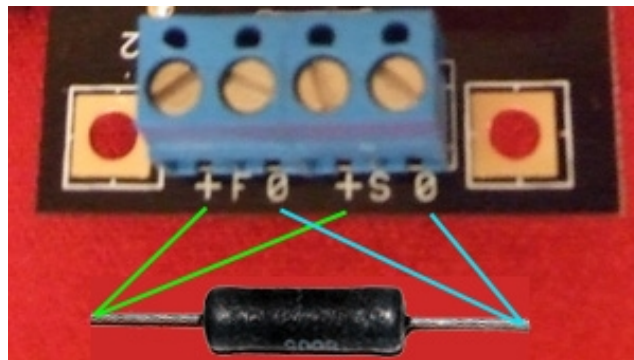

The dummy load resistor should be creating consumption around your real projected load current value so you can evaluate the kind of dissipation created on the sinks when in service. $I = V_{out}/R$. The dissipation on the dummy will be $I * V_{out}$. A 5W resistor will be enough in most cases.

Appendixes

1. The voltage reference area on the boards is the rectangle with SEE TEXT* mark. That includes places for two LEDs, one Zener, one resistor and one trimmer. Here is an picture from X30.

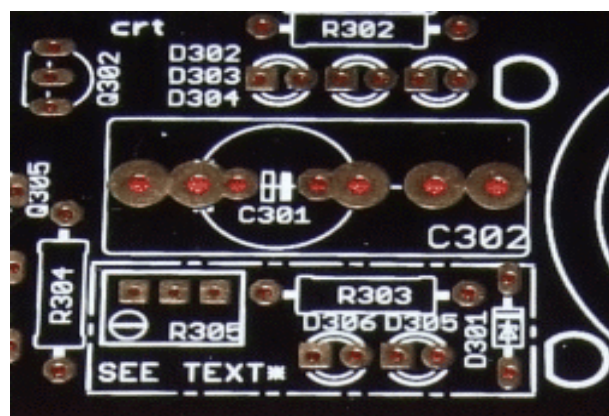

Examples for 3mA (in circuit) Q303 CCS current. R303=R103,203 also. Q303=Q103,203.

- a. 2.5-5.5V Vout BJT output reg. 1 red 1.9V LED, 1K trimmer. Other parts jumper.
 - b. 5V Vout Mosfet reg. 2 1.9V LED, 220 Ohm R303. Other parts jumper.
 - c. 10V-25V Mosfet reg. 2 1.9V LED, 1.8 kOhm R303. 5K trimmer. Other parts jumper.
 - d. 38V Mosfet reg. 2 1.9V LED, 33V 1/2W Zener, 220 Ohm R303. Other parts jumper.
 - e. 25-40V Mosfet reg. 2 1.9V LED, 6.8k R303, 5K trimmer. Other parts jumper.
- Prefer C302 MKT except for very sensitive digital like clocks or MC phono. There use C301 Electrolytic. Also when using fixed voltage with Zener.

Read below about inside works:

A typical flexible choice is a variable resistance "Norton" reference. R303 plus R305 will be dropping voltage as much as their total value $(R303+R305)*IQ303$. The LEDs help stability. The Zener position is shorted. Knowing your voltage target you can assign the larger resistance part to the fixed resistor R303 for being more stable and use a small value trimmer for fixing the voltage. $\frac{3}{4}$ to the resistor and $\frac{1}{4}$ to trimmer is practical. If you want it more general voltage span, then you may use small 220R R303 and a 10K trimmer value to cover wide settings. LEDs and Q304 will be contributing to total Vo. $D305+D306+Q303V_{be}$ give $\sim 4.4V$ additional. With 1.9V Vf (forward voltage drop) LEDs that is. LEDs rated for Vf @ 2-5mA will do fine.

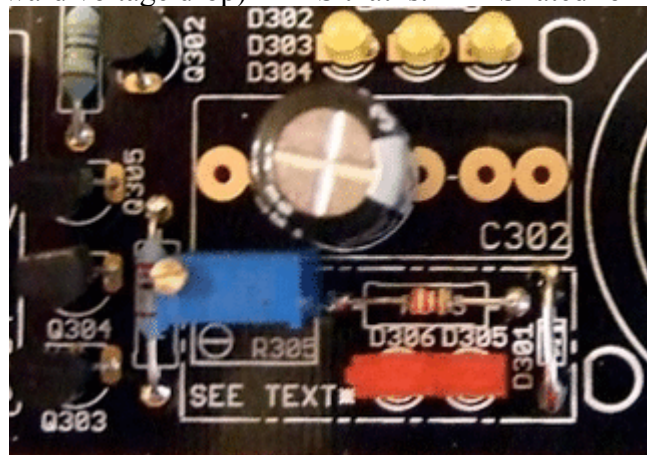

You could use instead a Zener based configuration. Will give a fixed low drift voltage setting. Add R303 220R 1/4W to aid noise filtering, jumper the LEDs and the trimmer positions. Use 220uF C302 50V. Not an MKT. Zeners need more filtering. There will be additional 0.6V from Q304 Vbe and R303's Voltage drop. $VR303=R303*IQ303$. Factor in the extra voltages. Q303 JFET will be weaker for IDSS in circuit from what you had measured with a 9V battery. A circa 4mA IDSS 9V testing JFET gives you around 3mA. If you still want keep the LEDs for indication, they will be adding their Vf too as in the first example. The higher the target Vout the more reliable a Zener reference is for low drift VS a resistor reference. You experiment and decide your priorities. A fully resistive choice can have smoother and lower noise spectrum to filter and lends for C102,202,302 MKT. 4.7uF-10uF. 10uF filters better. Electrolytic 220uF is even more efficient a filter for sensitive digital and MC phono stages, still for many buffer, line, MM, the MKT can be arguably enough and can give a different subjective impression you may prefer. More linear than Ecap. You taste in your application, you decide. The reg takes both.

2. Mosfet/BJT output

The Q106,206,306 (depending on which section board you work) is the shunt current element. If you need less than 5V output it has to be BJT due to Mosfet's $\sim 4V_{gs}$. Bipolar's Vbe is less. R106,206,306 MUST be 27R for BJT. Mosfet gives best low Zout.

The BJT is flat Zo and stable also. BOM lists the Mosfet and BJT type suitable.

3. Input section diodes & smoothing capacitor

For up to 200mA CCS current, MUR120 (DO-15 size) and 4700uF C105(205,305) are sufficient. For higher currents MUR820 TO-220 diodes and 10.000uF are recommended. There are positions for both diode types. You can use one or other, don't populate both. MUR820 will not need extra sinking for up to 1A. If sunk they need be insulated. See two examples of lighter and heavier current equipped prototype builds.

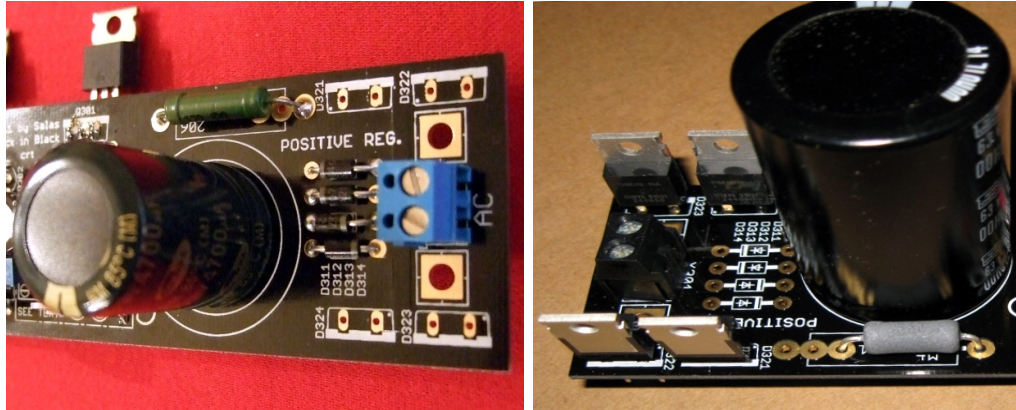

4. Output Zobel/Ecap

There is C104(204,304) Cout position. There an MKT & R107(207,307) form a Zobel. That way, given the minimal ESR of a plastic capacitor, the R element stays defined as designed in. An electrolytic can be used also as per BOM, in that case the R107,207,307 position MUST be shorted with a jumper. It is speedier using the Zobel, plastics are more linear also, still an Ecap is sometimes needed since it has bigger value and gives more damping if a load is much reactive or has unpredicted parallel parts on its rails, like very small decoupling elements, should you will notice instabilities cooperating with the reg. If there are no problems even with heavy current loads, the MKT + R is best.

5. JFETS/IDSS

Toshiba 2SK117GR is used, has shown better stability as a CCS than 2SK170 in this reg and more bandwidth. The noise is on par with 2SK170 but the capacitance is half. Its -Vp is also suitable for the small voltage margins in some crucial positions in this design.

By testing a few, 3-5mA IDSS range in the GREEN(GR) group were plenty.

You should select yours for falling in that range also, by following this tutorial:

http://www.diamondstar.de/transistor_matching_jfet.html

There is no need for strict matching, use your lower ones from the 3-5mA subgroup for Q102,202,302, your medium ones for Q103,203,303, and your stronger ones for Q105,205,305. Last but not least, 2SK117GR is currently cheaper and more available.

6. Sinking

Q101,201,301 is the CCS Mosfet. Q106,206,306 is the shunt element. Q101 will dissipate the $(DC_{in}-DC_{out}) * CCS$ current setting. Q106 will dissipate $DC_{out} * (CCS - LoadCurrent)$. From those Wattage products the sinking needs can be projected. If you will use a common sink 2C/W for 10W total dissipation, its temperature will rise +20 degrees C from ambient for instance. In most situations for up to 200mA settings and medium DCouts, sinking on metal enclosure floor or sides proves much tolerable. The

power semis can be set upright for side sinking or underneath for parallel sinking as in the picture. For low CCS setting and DCout, individual clip on sinks can do. Check the above $P=I*V$ conditions in your application thoroughly before any working attempts!

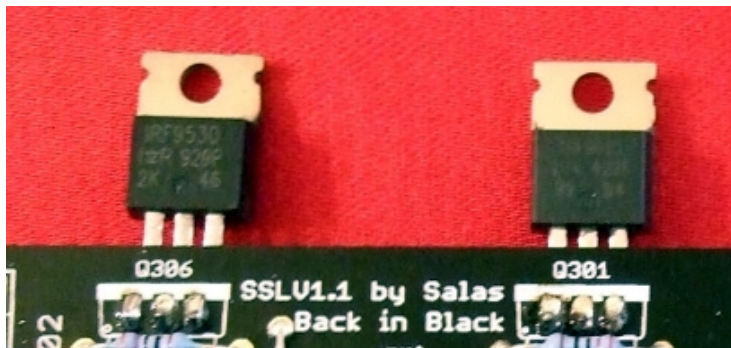

7. PARTS TYPES & VALUES LIST TO PRODUCE YOUR B.O.M.

Q101,301 IRF9610. Q201 IRF610

Q106,306 IRF9530, BJT MJE15031/15029 *About sinking for the power semis read appendix 6

Q206 IRF530, BJT MJE15030/15028

Q102,202,302,103,203,303,105,205,305 2SK117GR 3-5mA

Q104,304 BC550C

Q204 BC560C

(Dxx2,3,4) LEDs 3X or 4X 3-5mm Vf 2.1V per PCB section. 20mA. Color Green, Yellow.

(Dxx5,6) LEDs 2X 3-5mm Vf 1.9V per PCB section. 20mA. Color Red.

D101,201,301 Zener 0.5W *Refer to appendix 1.

Diodes MUR120 up to 200mA CCS. MUR820/40/60 for "hot-rod" or more. 4 per PCB section

C102,202,302,104,204,304 4,7uF-10uF/63V MKT radial 15-22.5mm lead pitch (PCM). 5-10%.

Examples: WIMA MKS4 4.7u/63, Vishay MKT1822 4.7u/63, KEMET (RIFA) MMK 10u/63.

Available at Mouser etc, MKS4 also on E-bay. **See appendixes 1&4 before ordering.

C101,201,301 220uF/50-63V. C103,203,303 47uF/50-63V. Preferred types for all: Nichicon Muse, Panasonic FC, Elna Silmic II. *Refer to appendix 1&4 before ordering.

C105,205 4700uF/63V pitch 10mm snap-in up to 200mA. 10000uF/63V 10mm snap-in "hot-rod"

R101,201,301 3 times higher W spec than their dissipation (voltage across each x CCS current).

*Refer to end of text on how to calculate their Ohmic values. 3-5W spec will usually be enough.

R102,202,302 270R. R106,206,306 270R/27R. 270R for MOSFET output. 27R for BJT output. 1/4W

R108,208,308 47R 1/4W

R104,204,304,107,207,307 1R 1/4W

For R103,203,303 1/4W resistors & R105,205,305 Trimmer Bourns 3296Y style, read appendix 1

X101,201,301 Molex 2 screw terminals 5mm pitch. X102,202,302 4 screw (or 2X 2screw interlocking). Silicon TO-220 pads, insulated screws, thermal grease for the power semis.

Transformer 50VA. 80VA hot-rod. Fuse to Tx primary rating. Calculate min 5VDCin more than DCout

GENERAL NOTE. Matching of LEDs and JFETS is not crucial. The reg will work anyway.

8. Schematics (BJT & MOSFET output, positive & negative)

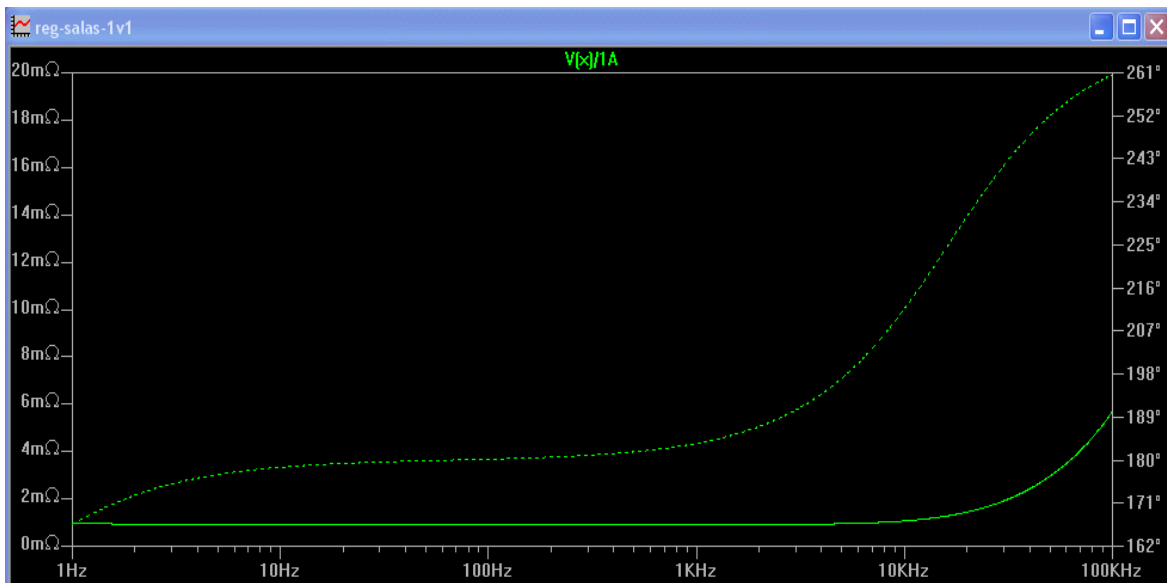
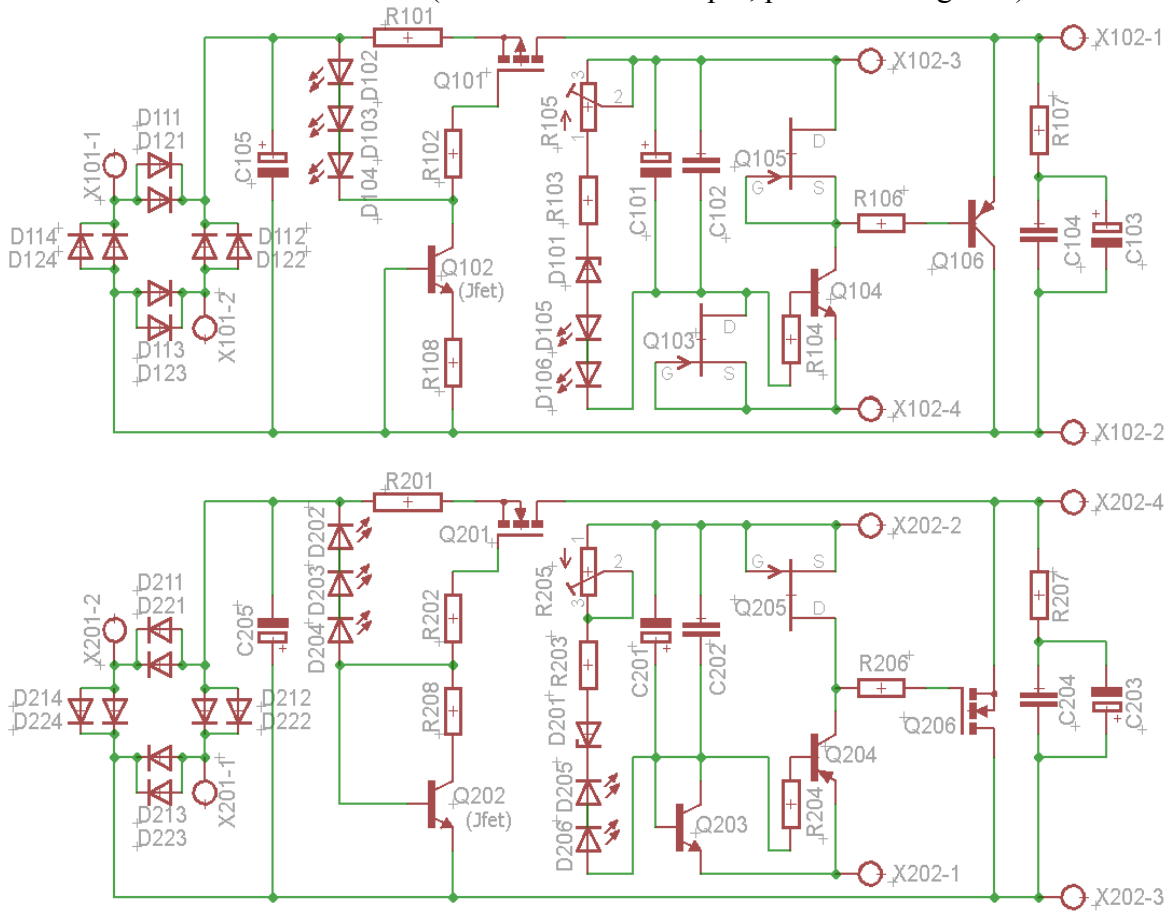

9. Simulation of output impedance for CCS=0.5A* "hot-rod" shunt=MOSFET

Same conditions (0,5A CCS, 50mA load), shunt=BJT.

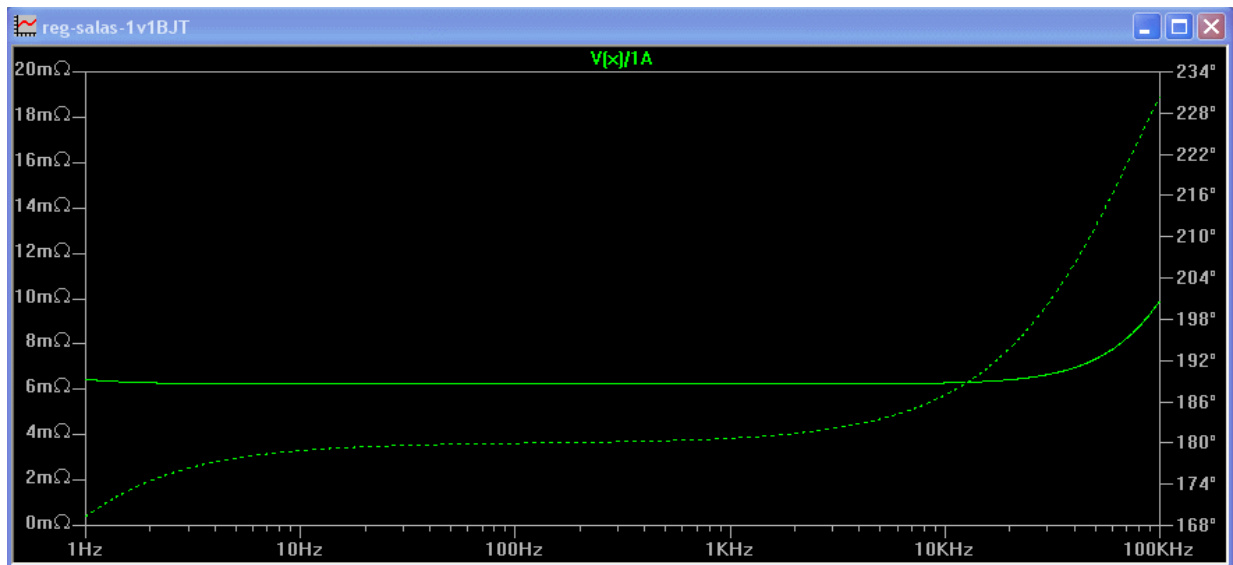

*By reading the ID/VGS curve you can have an idea of VGS at your projected CCS current. The curve differs enough in production, it is silicon wafer process related. This one is for the IRF9610. At current of 0.5A, it reads about 5.1V for instance. That value has to be subtracted from what forward drop is available by the LEDs array. What remains is the voltage across R101(201,301). By dividing that drop with R101 value in Ohm, the CCS current setting is found. In the newer batch of SSLV1.1 boards, 4 LED positions are available for ease in higher current settings. They can either be used for 3 LEDs and one of them be a wire jumper, or be fully populated if your current demands push VGS and your resistors stock fits higher values. Excess voltage across R101 when there is enough to set the CCS with fewer LEDs, only creates excess dissipation, gives no advantages. A ballpark example would be 15 Ohm and 4 green LEDs or 4.7 Ohm and 3 green LEDs for circa 200mA CCS.

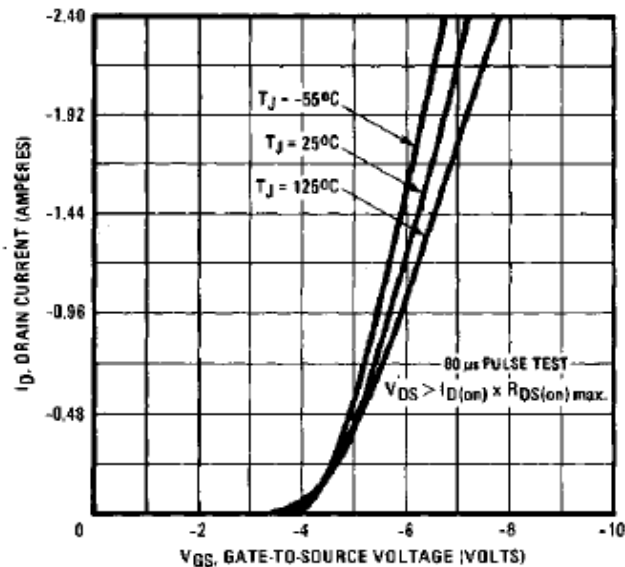

Written by Salas on May 2011. Thanking Crt & Tea-Bag for help, DiyA for enduring us all. :-)
No trade copying or reproduction of the circuitry, PCB, or text is endorsed without Salas's consent.

