



**CONTENTS**

- 1. Features . . . . . 1
- 2. Accessories. . . . . 1
- 3. Precautions . . . . . 2
- 4. Controls and connectors . . . . . 7
- 5. How to obtain the displays . . . . . 15
- 6. Method for connecting signals . . . . . 17
- 7. Measuring procedure . . . . . 20
- 8. Adjustments. . . . . 28
- 9. Maintenance . . . . . 29
- 10. Specifications . . . . . 29
- 11. External view . . . . . 33
- 12. Schematic diagrams . . . . . 35

### NOTE

- This instrument should be adjusted at an ambient temperature of  $+20^{\circ}\text{C}$  for best overall accuracy.  
Allow at least 15 minutes warmup before proceeding.
- Polyvinyl chloride (PVC) film is attached on the enclosure and the front panel of the oscilloscope to protect the metal surface. If the PVC film is damaged by scratches, remove it.
- To clean the enclosure or the front panel, use neutral detergent. Refrain from using thinner, benzine, alcohol or other chemicals.
- For safety operation, be sure to connect the ground lead of the GND (ground) terminal to earth ground, if a two-wire AC power system is used.  
Failure to complete the ground system may allow the chassis and cabinet of this instrument to be elevated above ground potential and pose a shock hazard.

## 1. FEATURES

The Hitachi V-212 [V-211] \* is a portable-type, advanced-class oscilloscope with a bandwidth of DC to 20 MHz designed with the emphasis on operability and portability and has following features.

\* [ ] : Specifications of V-211

### (1) Wide bandwidth:

The instrument has a bandwidth from DC to 20 MHz.

### (2) High sensitivity:

Sensitivity is 1 mV/div

### (3) Large 6" screen:

Employment of a large square CRT makes waveforms easier to observe.

### (4) Internal graticule:

Employment of an internal graticule CRT permits waveforms observation to be made without parallax error.

### (5) ALT TRIG

Even an observation of two waveforms of different frequencies, the waveform of the each channel is stably triggered.

(V-212 only)

### (6) TY synchronization:

Employment of a new TV sync separator circuit allows the instrument to observe TV signals stably.

## 2. ACCESSORIES

This instrument is shipped with the following standard accessories.

- 2 [1] Probes (AT-10 AQ 1.5)
- 1 AC power supply cord
- 1 Operation manual

### 3. PRECAUTIONS

Precautions to be observed to lengthen the service life of this instrument.

#### Installation site

- \* Avoid installing instrument in an extremely hot or cold place.
  - Avoid placing this instrument in a place exposed to sunlight for a long period of time, in a closed car in mid-summer, or near a room heating device such as a stove.
  - The operating maximum ambient temperature is +40°C.
- \* Do not use instrument that has been left outdoors on a cold winter day.

The operating ambient temperature is 0°C or more.

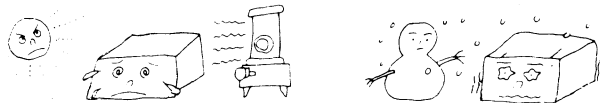

- \* Avoid moving the instrument rapidly from a hot place to a cold place or vice versa, or condensation may form inside of the instrument.
- \* Keep the instrument away from damp air, water, and dust. Unexpected trouble may be caused when the instrument is placed in a damp or dusty place.

The operating ambient humidity is 35–85%.

Since an accidental intrusion of liquid may also cause troubles, do not place a liquid-filled containers such as a vase on the oscilloscope.

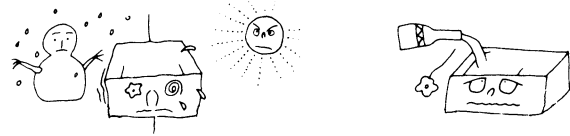

- \* Do not place the instrument in a place where vibration is strong. Avoid using the instrument at a place vibrating violently. Since the oscilloscope is a precision instrument, excessively strong vibrations may cause damage.
- \* Do not place the instrument near a magnet or magnetic body. An oscilloscope is an equipment using electron beam. Therefore, do not bring a magnet close to the instrument or do not use the instrument near an equipment generating strong magnetic force.

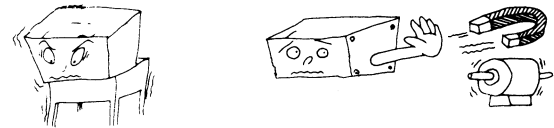

#### Handling

- \* Do not put a heavy objects on the oscilloscope.
- \* Do not block the ventilation holes.

- \* Do not apply a heavy shock to the oscilloscope.

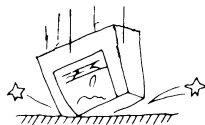

- \* Do not insert a wire, pin, etc. through the ventilation hole.
- \* Do not drag the set, leaving the probe attached to it.

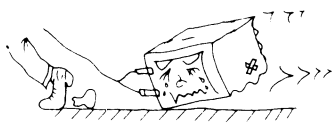

- \* Do not leave a hot soldering iron on the cabinet or the screen.
- \* Do not try to turn the instrument upside down. Otherwise, knobs may be broken.

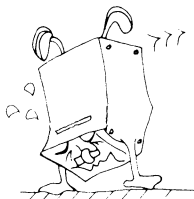
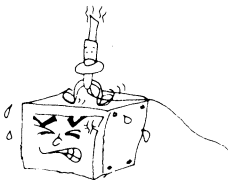

- \* Do not use the instrument upright, leaving BNC cable connected to EXT BLANKING terminal on the rear panel. Otherwise, the cable may be damaged.

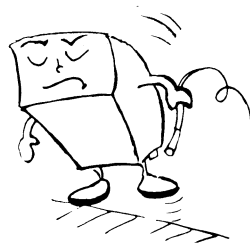

### When not in use

When not in use, put the dust-proof cover on the instrument and store it with care.

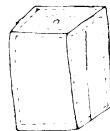

### When operation is faulty

Recheck the operating procedure and if problem persists, contact a nearby service station or agent.

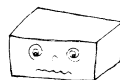

## Care and repair

- \* Removal of stain from the case.
  - When the outside of the case is stained, remove the stain by first wiping it lightly with a cloth moistened with neutral washing agent and then wipe the surface with a dry cloth.
- \* Never use strongly volatile agent such as benzine and thinner.



- When the panel surface is stained, remove the stain in similar way with a clean, soft cloth. When heavy stains are present, first remove the stains by wiping the surface lightly with a cloth moistened with diluted neutral washing agent or with alcohol and then wipe thoroughly with a dry cloth.
- When dust has accumulated on the inside, remove it by using dry brush, or by using the exhaust of a compressor or a vacuum cleaner. By a SERVICE PERSONNEL.

**NOTE:** When opening the case, pull out the power supply plug beforehand without fail.

When cleaning the inside, insure beforehand that no

electricity remains in the condensers of the power supply circuit. "NOT FOR AN OPERATOR"

## \* Cleaning of CRT

Dirty surface of CRT screen tends to cause measuring errors. The screen surface becomes accessible when the bezel is removed.

Remove the stains on CRT and filter by using a clean and soft cloth, paying attention not to impair them.

When the stain is extremely heavy, wash them with neutral washing agent and then leave them stand until the moisture is removed naturally.

- If the screen is installed while it is moistened, water rings may be formed and the waveform may be blurred to become hard to observe. Pay attention not to leave finger prints on it.

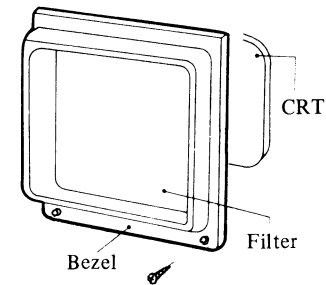

## Operation precautions

### \* Check the line voltage.

The operating voltage range of this oscilloscope is as shown below. Check the line voltage without fail before turning on the power switch.

Rating	Line Voltage (50/60Hz)
AC100V	AC 90V – 110V
AC120V	AC108V – 132V
AC220V	AC198V – 242V
AC240V	AC216V – 264V

Nominal volts  $\pm 5\%$  at 400Hz.

Prior to shipment, the voltage selector is set properly. When the oscilloscope is intended to be used on a different voltage, relocate the voltage selector in the procedures which follow.

- 1) Disconnect the power connector.
- 2) Insert a screwdriver into the right side of the cap and remove the fuse holder cap.
- 3) Mount the fuse holder cap into the fuse holder so that the marking of the correct voltage faces up.
- 4) Connect the power connector.

### \* Use only specified fuses.

In order to protect the circuit against overcurrent, a fuse of 2A (for AC100V or AC120V) or 1A (for AC220V or AC240V) is used on the primary side of power supply. When this fuse is blown out, check thoroughly the cause, repair any faulty point present, and then replace with a specified fuse. Do not try to use the fuse other than the specified ones. Otherwise, fault may be caused or danger may be invited.

(Particularly, do not use a fuse different from the specified one in current capacity and in length.) The standards of the fuses are as follows.

	Shape (Diameter x length) mm	JIS type name
2A	5.2 $\phi$ x 20	MQ4 – 2A (250V 2A UL)
1A	5.2 $\phi$ x 20	MQ4 – 1A (250V 1A UL)

### \* Do not increase the brightness too much.

Do not increase the brightness of the spot and trace too much. Your eyes may be strained and the fluorescent surface of CRT may be burnt.

**\* Do not apply an excessive voltage.**

The input withstand voltage of each input connector and probe input is as follows. Never apply a voltage higher than specified.

INPUT direct,	300V (DC + AC peak at 1 kHz)
When probe is used	400V (DC + AC peak at 1 kHz)
EXT TRIG INPUT	300V (DC + AC peak)
EXT BLANKING	30V (DC + AC peak)

### Calibration Interval

To maintain instrument accuracy, perform the calibration of the V-212[V-211] at least every 1000 hours of operation, or every six months if used infrequently.

## 4. CONTROLS AND CONNECTORS

### (1) Power supply and CRT

Operating voltage and fuse

This model can be operated from either a 100-volt, a 120-volt, a 220-volt or a 240-volt nominal line voltage source.

The line Voltage Selector on the rear panel, converts the instrument from one operating range to another. In addition, this Selector changes the primary connections of the power transformer to allow selection of one of four regulating ranges. The Selector also includes the line fuse. Use the following procedure to convert this instrument between nominal line voltage or regulating ranges.

1. Disconnect the instrument from the power source.
2. To convert from 100-volts nominal to 220-volts nominal line voltage or vice versa, pull out the Voltage Selector switch, and plug it back into the desired holes. Change power-cord set to match the power-source outlet.
3. Before applying power to the instrument, check the voltage indicator tabs on the Selector.

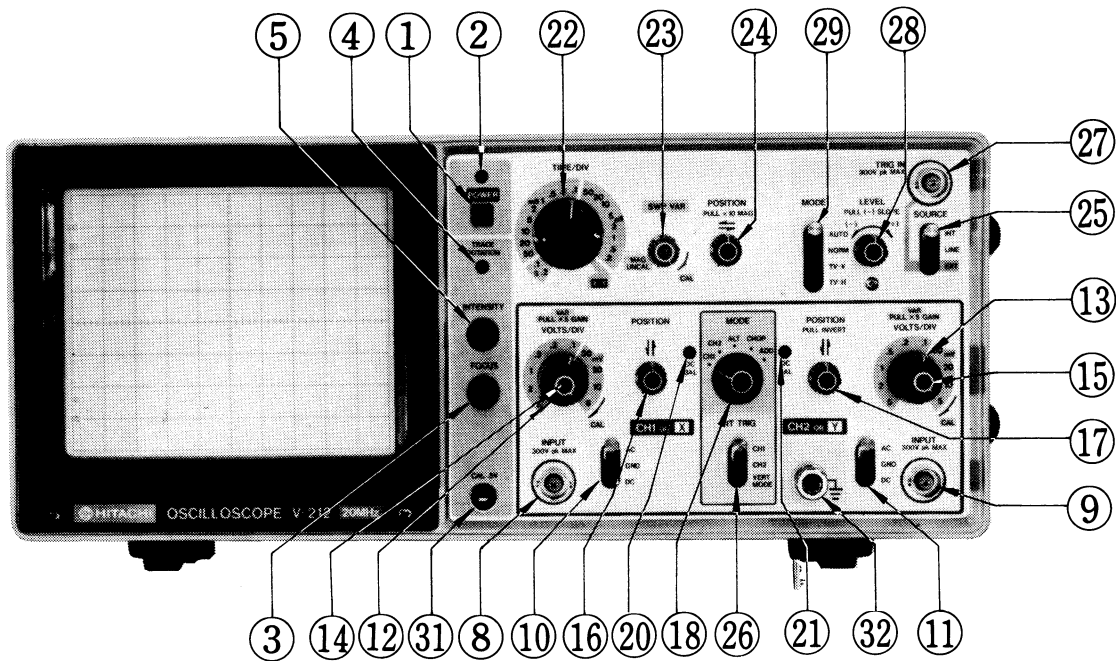

Fig. 4-1 V-212 Front View

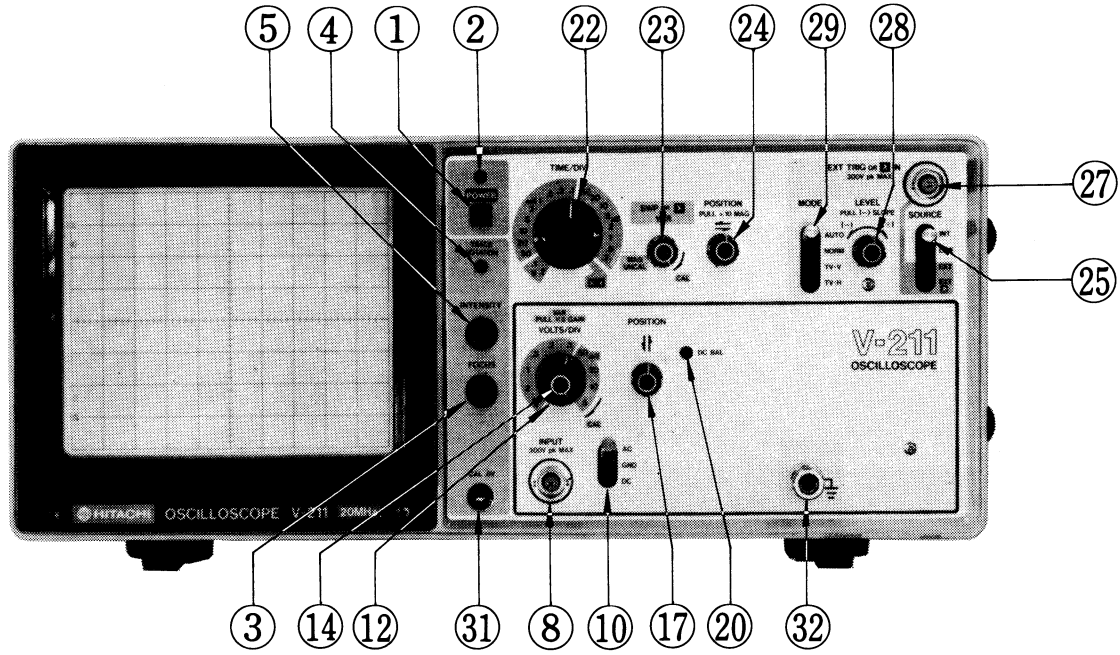

Fig. 4-2 V-211 Front View

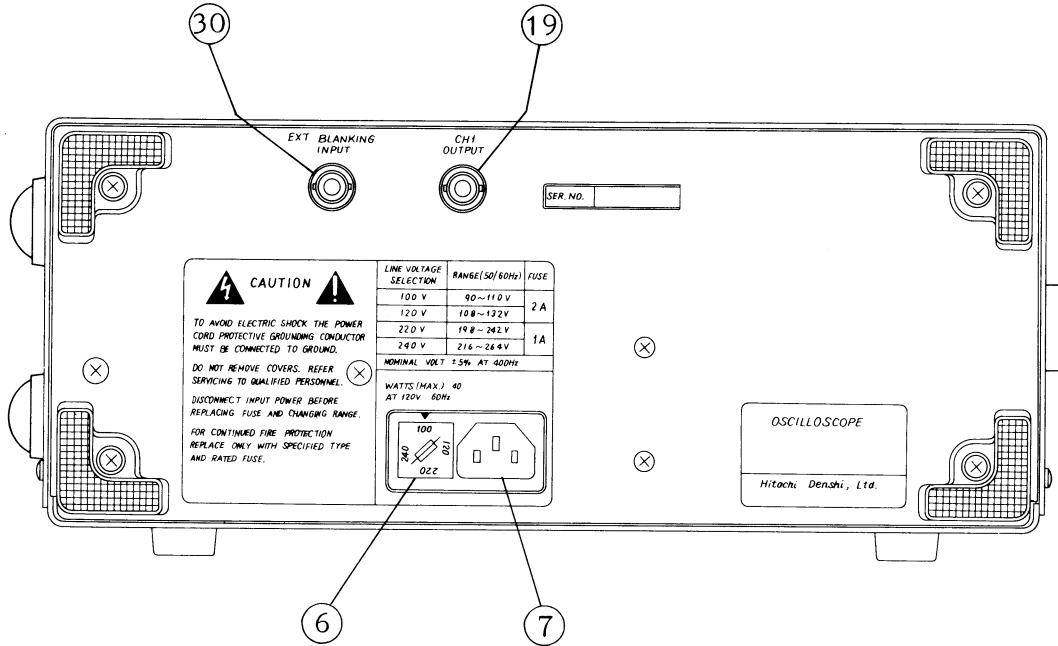

Fig. 4-3 V-212/V-211 Rear View

① **POWER switch**

The **POWER** is set on at the pushed-in position, and set off at the released position

② **POWER lamp**

This lamp goes on in red when the power supply is in ON state.

③ **FOCUS control**

After obtaining an appropriate brightness by operating **INTENSITY**, adjust **FOCUS** until the display is clearest.

④ **TRACE ROTATION control**

Used to aline the trace of CRT with the horizontal graticule.

⑤ **INTENSITY control**

This knob adjusts the brightness. Brightness is increased by rotating **INTENSITY** clockwise.

⑥ **VOLTAGE SELECTOR**

Used to select the power sources.

⑦ **AC inlet**

This is inlet for detachable AC power cord.

(2) **Controls of vertical deflection system**

⑧ **CH1 INPUT connector**

BNC connector for vertical axis input.

The signal input to this terminal becomes the X-axis [Y-axis] signal when the instrument is used as an X-Y oscilloscope.

⑨ **CH2 INPUT connector (V-212 only)**

The same as CH1, but when the instrument is used as an X-Y oscilloscope, the signal input to this terminal becomes the Y-axis signal.

⑩ ⑪ **Input coupling switches (AC-GND-DC)**

The switches used to select the coupling system between the input signal and vertical axis amplifier.

AC At this setting the signal is connected through a capacitor. The DC component of the input signal is cut off and only the AC component is displayed.

GND At this setting the input to the vertical axis amplifier is grounded.

DC At this setting the input signal is directly connected to the vertical axis amplifier and displayed unchanged, including the DC component.

## ⑫ ⑬ VOLTS/DIV select switches

A step attenuator which selects vertical deflection factor. Set it to an easily observable range corresponding to the amplitude of the input signal.

Multiply the reading by 10 when the 10:1 probe is used in combination with the instrument.

## ⑭ ⑮ VAR controls PULL x5 GAIN

Fine tuning device used to vary the vertical deflection sensitivity continuously. Attenuation of less than 1/2.5 is obtained when this device is rotated in the reverse direction of the arrow to the full.

This control is used when comparing waveforms or when measuring the rise time of a square wave in 2-channel observation. Normally this control is left rotated in the direction of the arrow to the full. When the knob is at PULL position (pulled up state) the gain of the vertical axis is magnified 5 times and the maximum sensitivity becomes 1mV/DIV.

## ⑯ POSITION controls

This knob is used to adjust the position of the vertical axis.

The display rises with a clockwise rotation of this knob and falls with a counterclockwise rotation.

## ⑰ POSITION control (V-212 only)

### PULL INVERT

The same as CH1, but when the knob is at PULL position (pulled up state), the polarity of the input signal applied to CH2 will be inverted.

This control is conveniently used in the comparison of two waveforms having different polarity or in the observation of the waveform of the difference between signals of CH1 and CH2 using ADD facility.

## ⑱ MODE select switch (V-212 only)

This switch is used to select the operation mode of the vertical deflection system.

CH1 Only the signal that has been applied to CH1 appears on the screen.

CH2 Only the signal that has been applied to CH2 appears on the screen.

ALT Signals applied respectively to CH1 and CH2 appears on the screen alternatively at each sweep. This setting is used when the sweep time is short in 2-channel observation.

CHOP At this setting the input signals applied to CH1 and CH2 are switched at about 250 kHz independent of the sweep and at the same time appear on the screen. This setting is used when the sweep time is long in 2-channel observation.

ADD The algebraic sum of the input signals applied respectively to CH1 and CH2 appears on the screen.

### ①9 CH1 OUTPUT connector

Output connector providing a sample of the signal applied to the CH1 connector.

### ②0 ②1 DC adjustment controls BAL

These are used for the attenuator balance adjustment. See 8. ADJUSTMENTS . . . for the details.

## (3) Controls of Horizontal deflection system

### ②2 TIME/DIV select switch

Sweep time ranges are available in 19 steps from 0.2  $\mu$ s/div to 0.2s/div.

X-Y This position is used when using the instrument as an X-Y oscilloscope.

V-212: In this position the X (horizontal) signal is connected to the input of CH1; the Y (vertical) signal is applied to the input of CH2 and has a deflection range from less than one millivolt to 5 volts/div at a reduced band-width of 500 kHz.

V-211: X(horizontal) direction signal is input to EXT TRIG or  IN ②7 and Y (vertical) direc-

tion signal to V-INPUT ⑧ . The vertical deflection sensitivity at this time is read on VOLTS/DIV and horizontal axis sensitivity is about 200 mV/div.

Vertical position is set by V-POSITION ①7 and horizontal position by H-POSITION ②4 .

### ②3 SWP VARIABLE control SWP or VAR control

This control works as CAL and the sweep time is calibrated to the value indicated by TIME/DIV.

TIME/DIV of sweep can be varied continuously when shaft is out of CAL position.

Then the control is rotated in the direction of arrow to the full, the CAL state is produced and the sweep time is calibrated to the value indicated by TIME/DIV. Counterclockwise rotation to the full delays the sweep by 2.5 times or more.

### ②4 POSITION control PULL x10 MAG

This knob is used to move the display in horizontal directions. It is indispensable in the measurement of the time of waveform.

Display is moved toward right when the knob is rotated clockwise and toward left with counterclockwise rotation.

Sweep is magnified 10 times by pulling out knob of POSITION. In this case the sweep time is 1/10 of the value indicated by TIME/DIV. Bring the position of the waveform desired to be magnified observed to the center of the scale by operating  $\rightleftarrows$  POSITION of the horizontal axis. Next, switch x10 MAG switch to PULL (pulled out state). Then the waveform placed at the center is magnified in right and left directions. The sweep time in this case is 10 times the sweep speed obtained by TIME/DIV, in other words, the reading is 1/10 of the sweep time indicated.

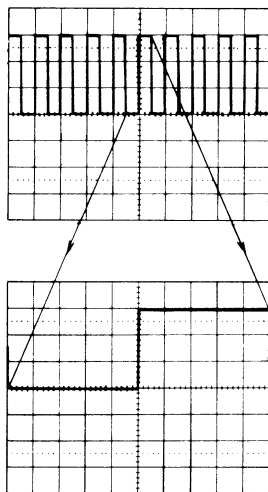

Magnified waveform

#### (4) Synchronization system

##### (25) SOURCE select switch (INT-LINE-EXT)

This switch is used to select the triggering signal source.

INT The input signal applied to CH1 or CH2 becomes the triggering signal.

LINE This setting is used when observing a signal with power supply line frequency.

EXT External triggering signal applied to TRIG INPUT becomes the triggering signal.

This setting is used when triggering with a special Independently of the vertical axis signal.

[ EXT  
X This select X input when the instrument is used as a X-Y oscilloscope. (V-211 only) ]

##### (26) INT TRIG select switch (V-212 only)

This switch is used to select the internal triggering signal source.

CH1 The input signal applied to CH1 becomes the triggering signal.

CH2 The input signal applied to CH2 becomes the triggering signal.

VERT MODE For observing two waveforms, the sync signal

changes alternately corresponding to the signals on CH1 and CH2 to trigger the signal.

**27 EXT TRIG or  IN connector**

Input terminal for use for external triggering signal.

The signal input to this terminal becomes the X-axis signal when the instrument is used as an X-Y oscilloscope. (V-211 only)

**28 Trigger LEVEL control  
PULL (–) SLOPE**

This knob is used to decide at which portion of the waveform should the sweep be started by setting trigger level. This knob is also enabled to switch SLOPE. Depressed position (normal state) is for  $\oplus$  SLOPE and PULL position (state in which the knob is protruding) is for  $\ominus$  SLOPE.

**Explanation of trigger polarity SLOPE**

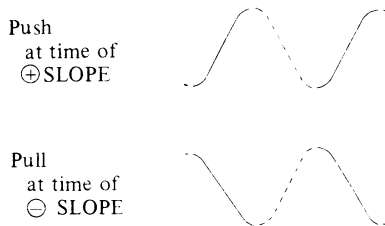

**Explanation of trigger LEVEL**

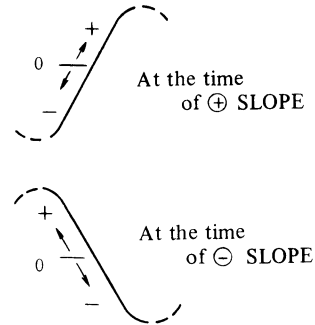

**29 Trigger MODE select switch**

- AUTO** The instrument is brought into automatically triggering sweep in which sweep is always conducted. In the presence of triggered signal, normal triggered sweep is obtained and the waveform stands still. In the case of no signal or out of triggering, sweep line will appear automatically. This setting is convenient in usual cases.
- NORM** Triggered sweep is obtained and sweep is conducted only when triggering is effected. No sweep line will appear in the case of no signal or out of synchronization. Use this mode when effecting synchronization to a very low fre-

quency signal (25 Hz or less).

**TV(V)** This setting is used when observing the entire vertical picture of television signal.

**TV(H)** This setting is used when observing the entire horizontal picture of television signal.

**(NOTE)** Both TV-V and TV-H synchronize only when the synchronizing signal is negative.

**(5) Miscellaneous**

**③⑩ EXT BLANKING INPUT connector**

Input terminal for brightness modulation. It is of the DC coupling. The brightness is reduced with a positive signal and increases with a negative signal.

**③① CAL 0.5V tip**

Output terminal of calibration square wave of about 1 kHz and 0.5V. It has a tip terminal. It is used to calibrate the probe combination.

**③② Grounding terminal**

Earth terminal of the oscilloscope.

**5. HOW TO OBTAIN THE DISPLAYS**

Before turning ON the POWER switch, insure the power supply voltage is within the range of 108–132V for AC 120V set, 198–242V for AC220V set, and 216–264V for AC 240V set.

Insert the plug of the power cord on the rear panel into the wall outlet and set the controls as follows.

<b>POWER</b> ①	OFF
<b>INTENSITY</b> ⑥	Counterclockwise to the full
<b>FOCUS</b> ③	Midrange
<b>AC-GND-DC</b> ⑪	GND
<b>POSITION</b> ⑬	Midrange (the knob is in the de-pressed)
<b>MODE</b> ⑱	CH1
<b>Trigger MODE</b> ⑲	AUTO
<b>Trigger SOURCE</b> ⑳	INT
<b>INT TRIG (V-212 only)</b>	CH1
<b>TIME/DIV</b> ㉒ ㉔	0.5 ms/div
<b>POSITION</b> ㉔	Midrange

Set all the levers of the switches to the upper side.

After ending all the setting mentioned above, turn ON the POWER and, 15 second later, rotate the INTEN knob clockwise. Then the display will appear. If the observation is to be started immediately, set the FOCUS control at a point where the display is sharpest.

If the instrument is not used with the power supply turned on rotate the INTENSity counterclockwise to reduce the brightness and also blur the FOCUS.

**NOTE**

For usual observation, leave the following non-calibrating function section set to "CAL" position.

VARIABLE	Rotate in the direction of arrow. In this case the VOLTS/DIV is calibrated to its indicating value.
SWP VAR	Leave the knob in depressed state. In this case the TIME/DIV is calibrated to its indicating value.

Align the base line with the horizontal scale line at the center of the screen by operating CH1 POSITION. In some cases the base line may be oblique to the scale slightly by the effect of earth magnetism. In this case, bring the base line until it lies on the horizontal scale line at the center of the screen by properly adjusting the semi-fixed variable resistor TRACE ROTATION on the front panel.

**GENERAL MEASUREMENT**

**(1) In the case of observing a single waveform.**

Use CH1 or CH2 when not observing the phase difference between two waveforms or when engaging in a operation other than X-Y operation. Make the following settings when using CH1.

MODE select switch (18)	CH1
Trigger MODE switch (29)	AUTO
Trigger SOURCE (25)	INT
INT TRIG (V-212 only) (26)	CH1

Under these settings almost all the repetitive signals of about 25 Hz or more applied to CH1 can be synchronized and observed by adjusting trigger LEVEL. Since the MODE of horizontal axis is at AUTO position, the base line appears even when no signal is present or when input coupling switch is at GND position. This means that the DC voltage can be measured. The following switching is needed when observing low frequency signals of about 25 Hz or less.

Trigger MODE (29)	NORM
-------------------	------

Synchronization can be effected by operating LEVER knob under this setting.

When using only CH2, use the instrument after making the following settings.

MODE select switch (18)	CH2
Trigger SOURCE (25)	INT
INT TRIG (V-212 only) (26)	CH2

## (2) When observing two waveforms

Observation of two waveforms can be made easily by setting the MODE switch of vertical axis to ALT or CHOP. When observing two waveforms of high repetition frequencies set the MODE switch to ALT and, in the case of low frequencies, set it to CHOP.

When measuring the phase difference, measure after effecting synchronization with leading phase signal.

## 6. METHOD FOR CONNECTING SIGNALS

The first step of measurement is introducing the signal desired to measure to the oscilloscope properly. Do it with utmost care.

### (1) When using a probe

Use the attached probe, AT-10 A Q1.5, when measuring a high frequency wave with high accuracy.

It should be noted, however, that since the input signal is attenuated by this probe to 1/10 before it is input to the oscilloscope the use of the probe is disadvantageous for low level signals, and that at the same time the measuring range is extended by that amount for high level signals.

### < CAUTIONS >

- Do not apply a signal which exceed 400V (DC + peak AC at 1 kHz).
- Bring the grounding point of the earth lead wire of the probe close to the point to be measured when measuring a rapid rising signal or a high frequency signal. Long earth lead wire may cause waveform distortions such as ringing and overshoot.

## Connection of earth lead wire

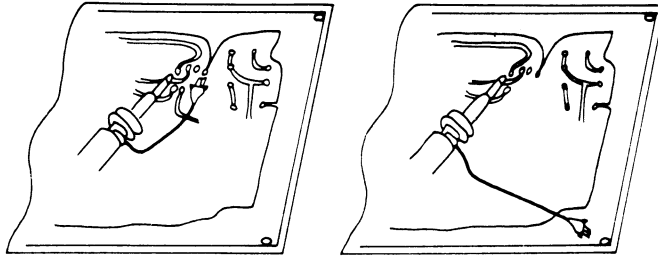

(a) A good example

(3) A bad example

- Multiply the reading of VOLTS/DIV by 10.  
For example, if the VOLTS/DIV is 50mV/DIV, then read the waveform as

$$50\text{mV/div} \times 10 = 500\text{mV/div}$$

- To avoid measurement error, put the probe in the following correction state and check it before measurement without fail.

Connect the tip of the probe to the CAL 0.5V tip of 1kHz calibration square wave.

When this correction capacity value is at optimum the waveform takes the shape as shown in Fig. (a).

If the waveform is as shown in Fig. (b) or Fig. (c),

rotate the trimmer on the matching box of the probe by using a screwdriver until the optimum state is obtained.

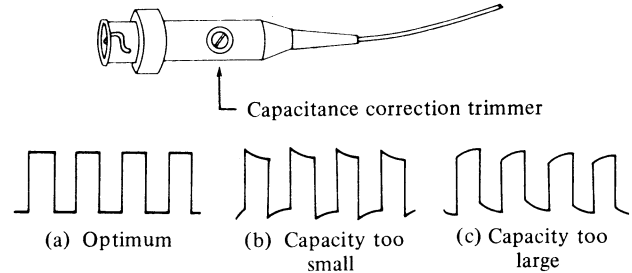

## (2) At time of direct connection

When connecting a signal directly to the oscilloscope not using the attached probe AT-10AQ1.5 (10:1), pay attention to the following points in order to minimize the measurement error.

- When performing observation using a bare lead wire, no trouble occurs of the circuit to be measured is of low impedance and high level.

However, note that, in most cases, measurement error may be caused by static stray coupling with other circuit and power line.

This measurement error cannot be ignored even in low frequency region.

In general, it is safe to avoid measuring with non-shielded connecting wire. When using a shielding wire connect one end of the shield to the earth terminal of the oscilloscope and the other end to the grounding of the circuit to be measured. It is desirable to use a coaxial cable with BNC type connector.

- The following cautions must be observed when performing a wide band measurement.

It is necessary to terminate with the characteristic impedance of the cable when measuring a rapid rising waveform or a high frequency wave.

Especially when using a long cable, the absence of a terminating resistor will necessarily lead to a measurement error derived from ringing phenomenon. Some measuring circuits require a terminating resistor equal to the characteristic impedance of the cable also on the measurement terminal side.

BNC type terminating resistor ( $50 \Omega$ ) is conveniently used for this purpose.

- In order to perform measurement with the measuring circuit put in proper operating state it is sometimes necessary to terminate the cable with an impedance which corresponds to the circuit to be measured.
- The stray capacity of the shielded wire must be taken into account when performing measurement with a long shielded wire. Since the shielded wire normally in use has

a capacitance of about 100 pF per meter, its effect on the circuit to be measured cannot be ignored. Use a probe to minimize the effect on the circuit.

- When the length of the shielded wire used or when the length of the non-terminated cable reaches  $1/4$  wave length or its multiples within the band of V-212 [V-211] type ( $1/4$  wave length is about 3 meter when using a coaxial cable at 20 MHz), oscillation may be caused at 5 m V/DIV or near range.

This is caused by the resonance between the externally connected high-Q inductance and the input capacity and can be avoided by reducing the Q.

Connect the cable or shielded wire to the input connector by way of a serially connected  $100\Omega$  to  $1 \text{ k}\Omega$  resistor, or perform measurement at other VOLTS/DIV range.

### (3) When observing waveform with X-Y

Set the TIME/DIV switch to X-Y. Then the instrument works as an X-Y oscilloscope.

Each input is applied to the instrument as follows.

X-axis signal (horizontal axis signal)

CH1 INPUT [TRIG or XIN]

Y-axis signal (vertical axis signal)

CH2 INPUT [ V INPUT]

In this case leave the horizontal axis magnification switch (PULL-MAG  $\times 10$  knob) at depressed position.

## 7. MEASURING PROCEDURE

The first things to do are as follows.

- Bring the brightness and FOCUS at optimum positions for easy read out.
- Display the waveform as large as possible to minimize the read error.
- Check the capacity correction when using a probe. (Refer to Paragraph (1) “When using a probe” of Section 6. “Method for connecting signals” for the method for correcting capacity.)

### (1) DC voltage measurement

Set input coupling to GND and decide the zero level properly.

Set VOLTS/DIV appropriately and set AC-GND-DC to DC. Since the base line shifts here by the amount of DC voltage, the DC voltage of the signal can be obtained by multiplying the shift width by the indicated value of VOLTS/DIV. When VOLTS/DIV is 50 mV/DIV, then  $50 \text{ mV/div} \times 4.2 = 210 \text{ mV}$  (However, if the probe AT-10 AQ 1.5 is in use, the true value of the signal becomes 10 times the value, or  $50 \text{ mV/div} \times 4.2 \times 10 = 2.1 \text{ V}$ .)

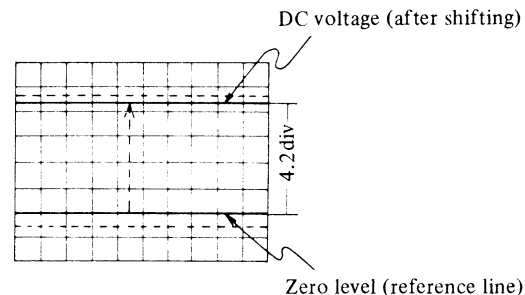

### (2) AC voltage measurement

The same as paragraph 7 (1), “DC voltage measurement”, but here there is no need of matching the zero level with the scale line. Move the zero level at will to a position easy to observe.

In the drawing as follows, VOLTS/DIV is 1V/DIV,  $1\text{V/div} \times 5 = 5 \text{ Vp-p}$  (50 Vp-p at time using the probe AT-10 AQ 1.5). When magnifying and observing a small-amplitude signal, superimposing on a high DC voltage, set input coupling to AC. The DC voltage is cut off and AC voltage can be observed by increasing sensitivity.

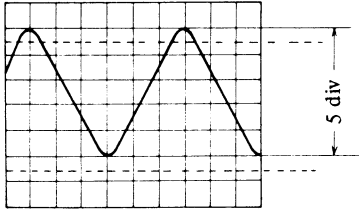

### (3) Measurement of frequency and period

This will be explained taking the drawing at follows as an example.

One period covers the time A and time B, which are separated from each other by 2.0 div on the screen.

When the sweep time is 1 ms/DIV, the period is given by

$$1 \text{ ms/div} \times 2.0 = 2.0\text{ms}$$

$$= 2.0 \times 10^{-3} \text{ S}$$

Accordingly, the frequency is

$$1/(2.0 \times 10^{-3}) = 500 \text{ Hz}$$

(However, when the knob MAG  $\times 10$  is at pulled out position, TIME/DIV must be converted to 1/10 since the sweep is magnified.)

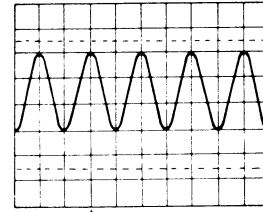

Time A Time B

### (4) Measurement of time difference

Triggering signal source "SOURCE" is selected as offering reference signal when measuring the time difference between two signals. Assume that pulse trains as shown in (a). Then (b) shows the case when CH1 is taken as the triggering signal source and (c) the case where CH2 is taken.

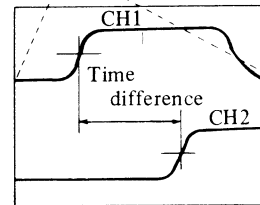
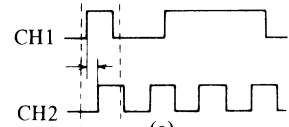

(b)

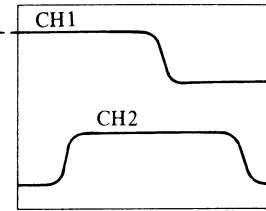

(c)

This means that CH1 is used as the triggering signal when investigating the length of time by which the signal of CH2 is delayed from the signal of CH1. CH2 is used in the reversed case. In other words, the signal leading in phase is selected as the triggering signal source.

If this process is reversed, the portion to be measured may sometimes not appear on the screen. Thereafter, equalize the amplitudes of the two signals appearing on the screen or superimpose one on another.

Read the time difference by the interval between 50% amplitude points of the two signals.

Sometimes the superimposing method is more convenient from the point of view of procedure.

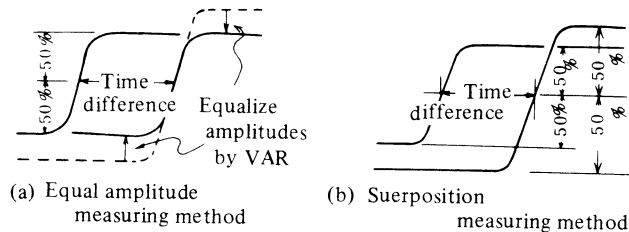

### < CAUTIONS >

Since the pulsed wave contains many high-frequency wave components (higher harmonics) depending on its width or

period, pay the same attention as given to high frequency signals when handling it. Accordingly, use a probe or coaxial cable and shorten the earth lead wire as much as possible.

### (5) Measurement of rise (fall) time

To measure the rise time pay attention not only to the abovementioned items but also to measurement error. The following relationship exists between the rise time  $T_{rx}$  of the waveform to be measured, the rise time  $T_{rs}$  of oscilloscope, and the rise time  $T_{ro}$  displayed on the screen.

$$T_{ro} = \sqrt{T_{rx}^2 + T_{rs}^2}$$

When the rise time of the pulse going to be measured is sufficiently longer than the rise time of the oscilloscope (7ns in our case), the effect of the rise time of the oscilloscope on the measurement can be neglected. However, if both are close to each other, measurement error may be caused.

The true rise time is given by

$$T_{rx} = \sqrt{T_{ro}^2 - T_{rs}^2}$$

Moreover, in general, in a circuit free from waveform distortion such as overshoot and sag, the following relationship is established between frequency band and rise time.

Where,  $f_c \times t_r = 0.35$   
 $f_c$  : Frequency band (Hz)  
 $t_r$  : Rise time (s)

The rise time and fall time are determined by the time elapsed between the 10% to 90% values of pulse width. This oscilloscope is provided with graduations for 0%, 10%, 90%, and 100% on the screen, which facilitate measurement.

### (6) Synchronization of complexed waveform

In the case shown in Fig. (a) where two waveforms greatly different in amplitude alternate, the waveform is doubled if the trigger level is not set properly. In the case where the trigger level is selected as Y line two waveforms, one starting with A and advancing to B, C, D, E, F, . . . and the other starting with E and advancing to F, G, H, I . . . , will appear alternately on the screen. They will be doubled as shown in Fig. (b), for which no synchronization can be taken.

In such a case, rotate LEVEL clockwise until the trigger level comes to Y' line. Then the waveform on the screen becomes the one is shown in Fig. (c) which start with B and advances to C, E, F, . . . and which allows synchronization.

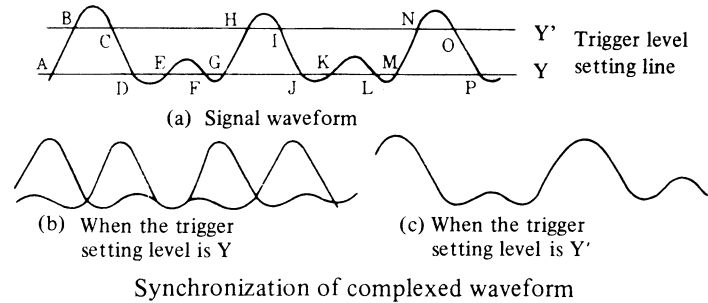

### (7) Synchronization of observing two waveforms (V-212 only)

- ① When two signals of CH1 and CH2 have same frequencies or the frequencies of an integral number or the frequencies in a relation of a specific time difference, the INT TRIG switch selects either CH1 or CH2 as a reference signal. CH1 position selects CH1 signal as a reference, and CH2 position selects CH2 signal.
- ② For an observation of signals of different frequencies, set the INT TRIG switch to the VERT MODE. The sync signal switches at each alternation of channels, and the waveform of the each channel is stably triggered.

## SELECTION OF A TRIGGER SOURCE ON THE VERT MODE

A trigger signal is obtained in the following steps.

- 1) Set the SOURCE switch (25) to INT.
- 2) Set the INT TRIG switch (26) to VERT MODE.
- 3) Select the MODE switch (18).

**Table 1. Relation of trigger signal sources and switches**

SOURCE		INT			LINE	EXT
INT TRIG		CH1	CH2	VERT MODE	Line	External
V	CH1	CH1	CH2	CH1		
	CH2	CH1	CH2	CH2		
M O D E	ALT	CH1	CH2	CH1,CH2 (ALT)		
	CHOP	CH1	CH2	ADD		
	ADD	CH1	CH2	ADD		

When the SOURCE switch to INT, INT TRIG switch to VERT MODE, and MODE switch to ALT, the input signals applied to CH1 and CH2 become trigger source alternatively at each sweep. Consequently, even for an observation of two waveforms of different frequencies, the waveform of the each channel is stably triggered.

In this case, the signal should be applied to both CH1 and CH2, and the two signals have the same level portion in excess of the rated amplitude each other. There should be a common portion of levels available that is above the rated amplitude of CH1 and CH2.

When a sinewave is applied to CH1, and a square wave is applied to CH2, "A"s in Fig. 1 are the levels possible for synchronization.

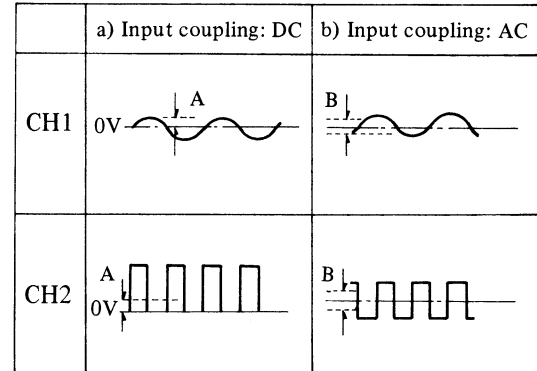

**Fig. 1**

In order to expand the synchronization range, AC coupling is applied to the CH2 side.

When either the CH1 or CH2 input signal is smaller as shown in Fig.2, adjust the VOLTS/DIV switches (12) and (13) to obtain sufficient amplitudes.

The VERT MODE triggering requires 1.5 div more than the amplitude required for an observation of CH1 or CH2.

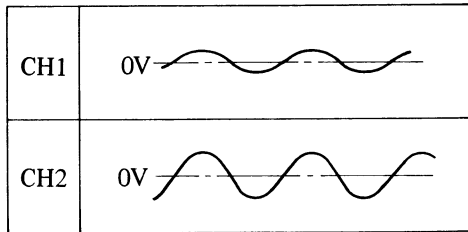

Fig. 2

The VERT MODE triggering is not possible when the signal is applied to only one channel as illustrated on Fig. 3.

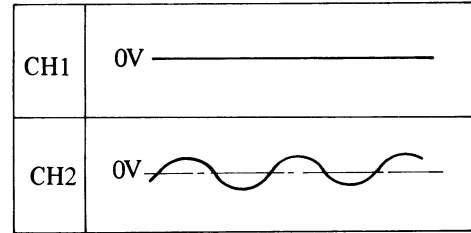
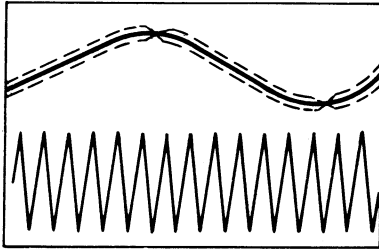

Fig. 3

**Cautions :** Do not use the INT TRIG to the VERT MODE when VAR PULL x5 GAIN (14) and/or (15) are in the pulled out position (x5 GAIN mode).

## ALTERNATE TRIGGER

Jittering wave as shown below may appear on the screen when a gently-sloping signal is displayed by approximately 10 cycles or less, with the VERT MODE for the INT TRIG switch and the ALT position for the MODE select switch. For detailed and clear observation of each signal, set the MODE select switch to the CH1 or CH2.



## (8) How to use TV exclusive synchronization

### ① On the video waveform of TV

In the work concerned with TV, complexed signals containing video signal, blanking pedestal signal, and synchronizing signal are often measured. However, since the waveform is complexed, a special circuit is needed to effect a stable synchronization with vertical waveform.

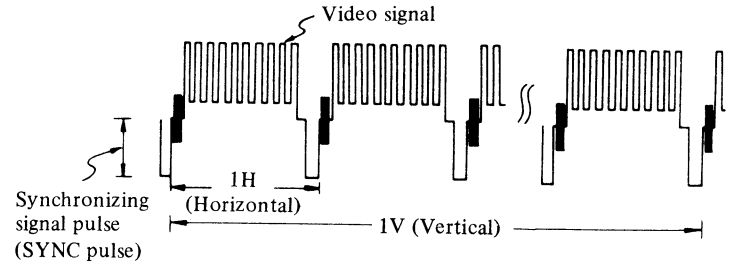

② Difference in the circuits

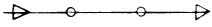
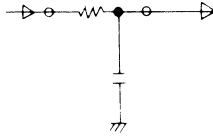
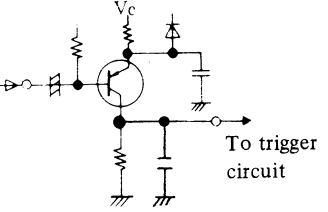
	Exclusive circuit for conventional oscillograph		Exclusive circuit for this instrument (Principle drawing)
	General circuit	Simple synchronizing circuit	TV exclusive synchronizing separator circuit
Circuits	<p>Video signal</p> <p>To trigger circuit</p> 	<p>To trigger circuit</p> 	
	<p>Hard to synchronize, because video signal is applied directly as trigger signal.</p>	<p>Synchronization is more easily effected than in the circuit shown at left, because the signal is integrated to remove high frequency components.</p>	<p>Stable synchronization is obtained since SYNC pulse is picked up, amplified, and then integrated to remove high frequency components.</p>

### ③ Operation

To observe vertical signal

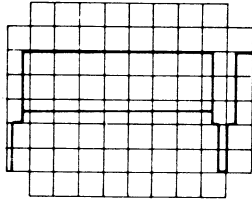

TRIG MODE: TV-V

To observe horizontal signal

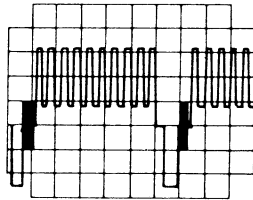

TRIG MODE: TV-H

(NOTE) This oscilloscope synchronizes with only (-) synchronizing signal.

(REFERENCE)

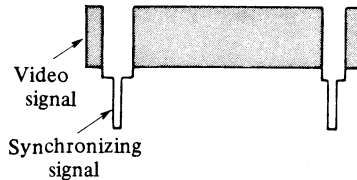

(a) Example of (-) synchronizing signal

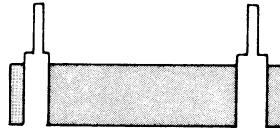

(b) Example of (+) synchronizing signal

## 8. ADJUSTMENTS

The ATT balance of the vertical axis can be made easily.

- ① Set the input coupling switches of CH1 and CH2 to GND and set the TRIG MODE to AUTO. Then position the base line to the center.
- ② Turn the VOLTS/DIV switch to 5mV-10mV and adjust so that the base line does not move. (BAL <sup>DC</sup> 20 21)

## 9. MAINTENANCE

- 1) Since semiconductors, precision components, etc. are employed in this oscilloscope, use at most care for operation and storage.
- 2) Clean the screen with soft tissue periodically.
- 3) Side panel can be removed with a screw driver.
- 4) Store this oscilloscope in the ambient temperature from -10 to +60°C.

## 10. SPECIFICATIONS

### CRT

#### Type

6" screen with internal graticule  
Approximate 2kV acceleration potential

#### Phosphor

P31 standard

#### Graticule

8 x 10 div (div = 10 mm)  
Internal graticule

**Focussing** Possible

**Trace rotation** Provided

**Brightness adjustment** Possible

### Z-AXIS INPUT (INTENSITY MODULATION)

DC-coupled, positive-going signal decreases intensity:  
5Vp-p signal causes noticeable modulation at normal  
intensity: DC to 2MHz

**Input impedance** 47 kohm (typ.)  
**Maximum input voltage** 30 V(DC +peak AC)

### VERTICAL DEFLECTION SYSTEM (2 identical channels)

#### Bandwidth and rise time

DC to at least 20 MHz and rise time 17.5 ns or less DC to at least 7 MHz and rise time 50 ns or less at magnifier extends. The AC coupled lower -3dB point is 10 Hz or less.

#### Deflection factor

5mV/div to 5V/div in 10 calibrated steps in a 1-2-5 sequence. Uncalibrated continuous control extends deflection factor to at least 12.5 Volts per division in the 5 Volts/div position. x5 magnifier increases sensitivity of each deflection factor setting to 1mV/div.

#### Accuracy

±3%  
Additional error for magnifier ±2%.

#### Display modes

CH1, CH2 (normal or invert), Alternate, Chopped (approximate 250kHz), Added

#### Input impedance

Approximately 1 MΩ in parallel with 25 pF

#### Maximum input voltage

300V (DC + peak AC) or 500 Vp-p AC at 1kHz or less

#### Input coupling

AC, GND, DC

### HORIZONTAL DEFLECTION SYSTEM

#### Time base

0.2μs/div to 0.2s/div in 19 calibrated steps in a 1-2-5 sequence. Uncalibrated continuous control extends deflection factor to at least 0.5 seconds per division in the 0.2 sec/div position. x10 mag extends maximum sweep rate to 100 ns/div.

#### Accuracy

±3%  
Additional error for magnifier ±2%

### TRIGGERING SYSTEM

#### Trigger modes

Automatic, Normal, TV (TV-H or TV-V)

### Trigger source

V-212 : Internal (Ch1, Ch2, V-MODE), Line, External

V-211 : Internal, Line, External, EXT-H

### Trigger slope

+, -

### TV sync polarity

TV (-)

### Triggering sensitivity and frequency

Frequency	Internal (V-MODE)	External
20 Hz – 2 MHz	0.5div (2.0 div)	200 mV
2 MHz – 20 MHz	1.5 div (3.0 div)	800 mV

(V. MODE): V-212 only

TV-V sensitivity: SYNC section less than 1 div or 1V

AUTO low band: Approximately 25 Hz

### Trigger coupling

AC : 20 Hz to full bandwidth

### External trigger input impedance

Approximately 1 MΩ in parallel with 25 pF  
[X-Y ; about 100 kΩ (V-211 only)]

### Maximum input voltage

300V (DC + peak AC)

### X-Y OPERATION (CH1; Horiz, CH2; Vert)

### Deflection factor

Same as vertical deflection [X-axis : about 200 mV/div]

### X-bandwidth

DC to at least 500kHz

### Phase error

3° or less from DC to 50kHz [ DC to 10 kHz ]

### CALIBRATOR

An approximate 1kHz 0.5V ±3% square wave

### SIGNAL OUTPUT

#### CH1 VERT SIGNAL OUTPUT

Output voltage is at least 20 mV/div into a 50 ohm load.  
Bandwidth is 50 Hz to at least 5 MHz.

**POWER SUPPLY**

Approx. 6 kg (13.5 lbs)

VOLTAGE (50/60Hz)	FUSE
100 V ( 90 – 110 V)	2A
120 V (108 – 132 V)	2A
220 V (199– 242 V)	1A
240 V (216– 264 V)	1A

**Power supply frequency:** 50, 60, 400 Hz**Power consumption:**      Approx. 30W  
  Max. 40W at 120V 60Hz**ENVIRONMENT**

<b>Limit of operation temperature</b>	0 to +40°C (32 to 104°F)
<b>Limit of operation humidity</b>	35 to 85%
<b>Rated range of use temperature</b>	+10 to +35°C (50 to 95°F)
<b>Rated range of use humidity</b>	45 to 85%
<b>Storage and transport temperature</b>	-20 to +70°C (-4 to +158°F)

**DIMENSIONS AND WEIGHT**Approx. 310(W) x 130(H) x 370(D) mm  
(12.4(W) x 5.2(H) x 14.8(D) inches)

# 11. EXTERNAL VIEW

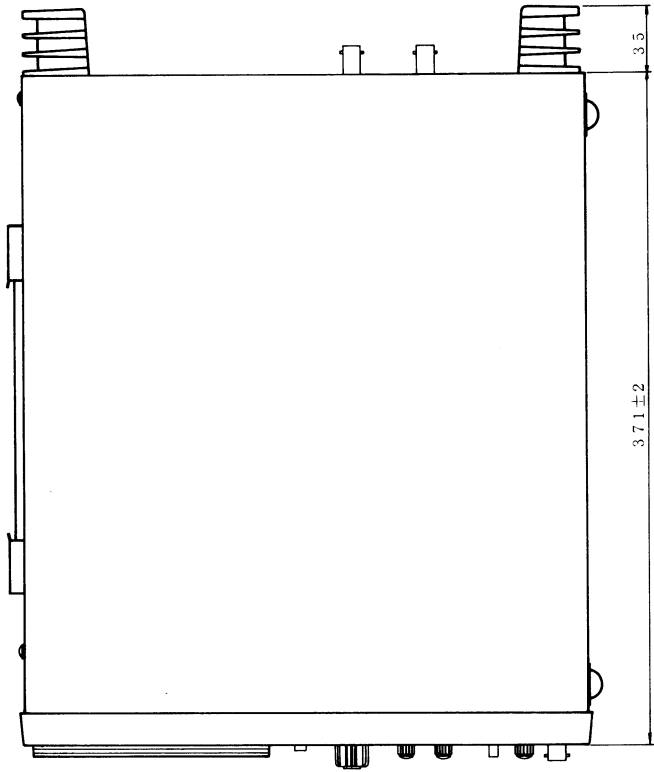

V-212

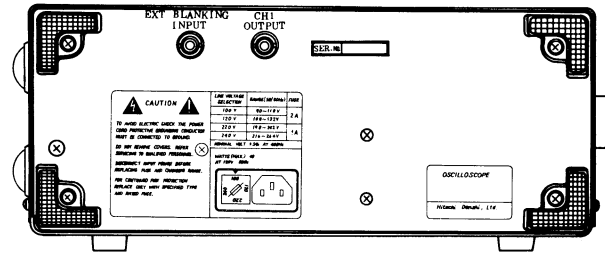

TOP VIEW | REAR VIEW  
FRONT VIEW

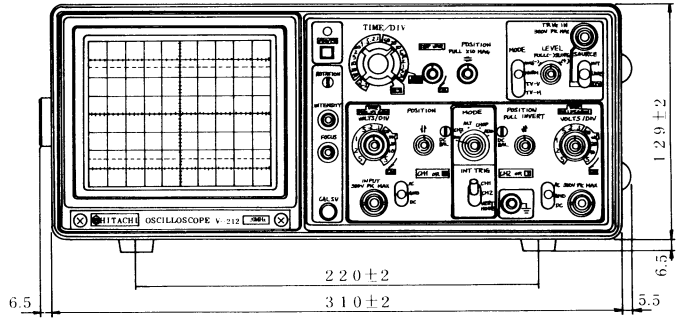

Unit: mm

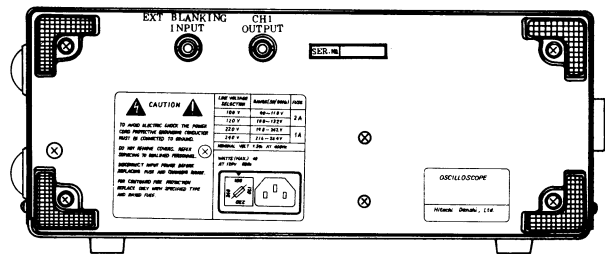
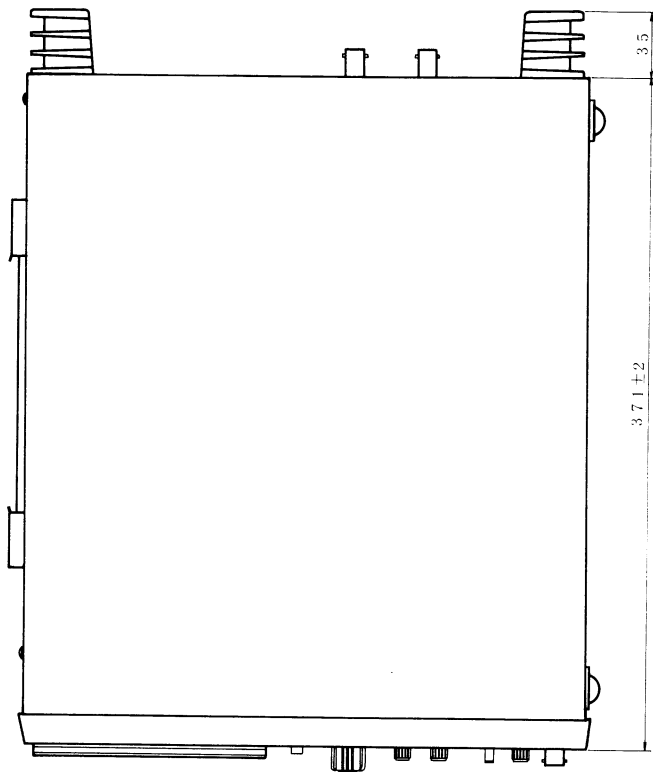

TOP VIEW ↙ REAR VIEW  
 ↘ FRONT VIEW

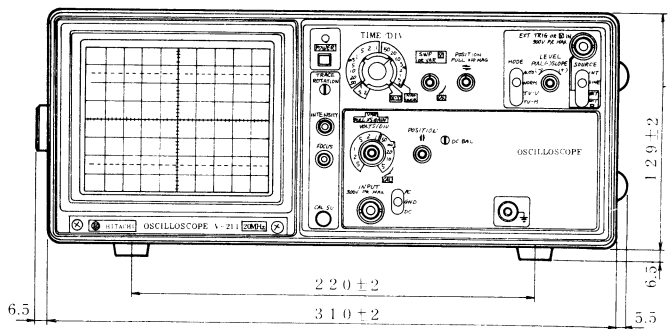

V-211

Unit: mm

# 12. SCHEMATIC DIAGRAMS

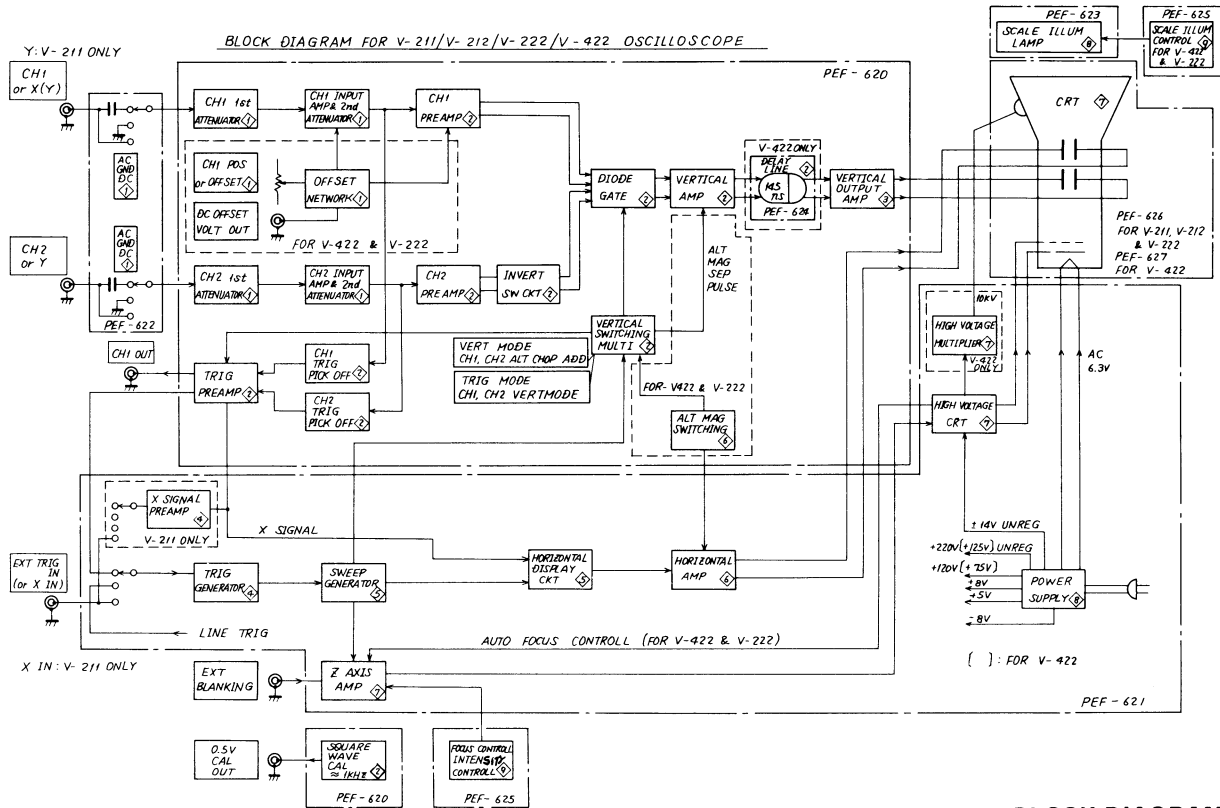

**BLOCK DIAGRAM**

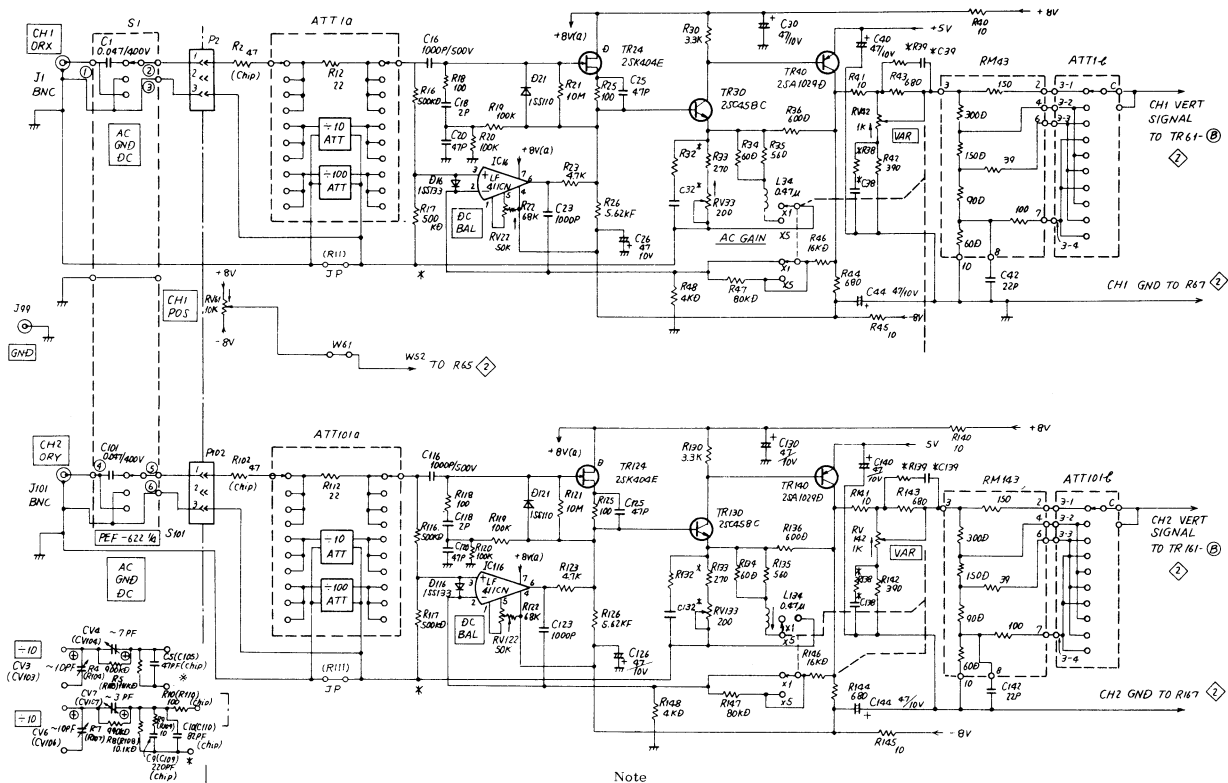

- Note
1. All of the basic circuit diagrams are subjects to change without notice.
  2. All resistor values in ohm: 1/4W and all capacitor values in microfarad unless indicated.
  3. \* Factory selected values.

**V-212**  
**INPUT AMP** 1



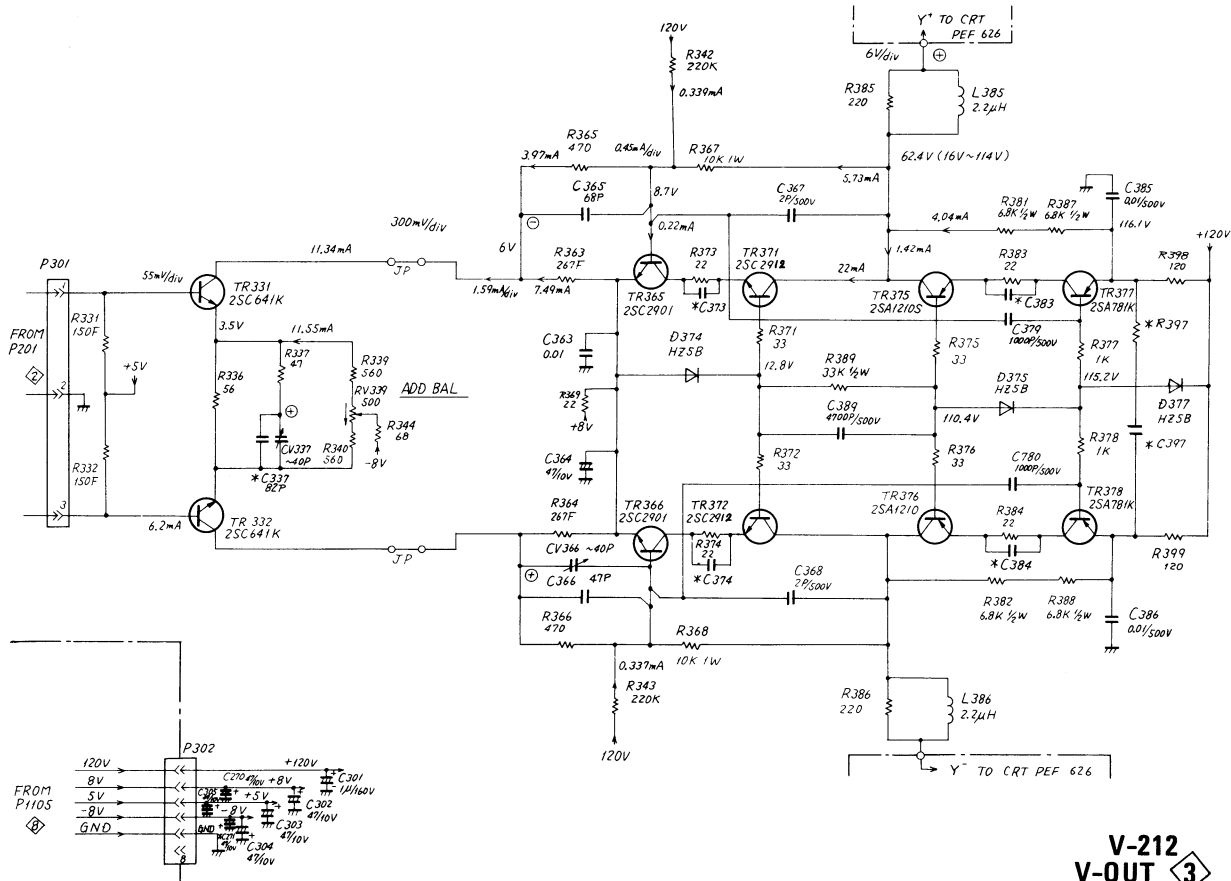

V-212  
V-OUT 3

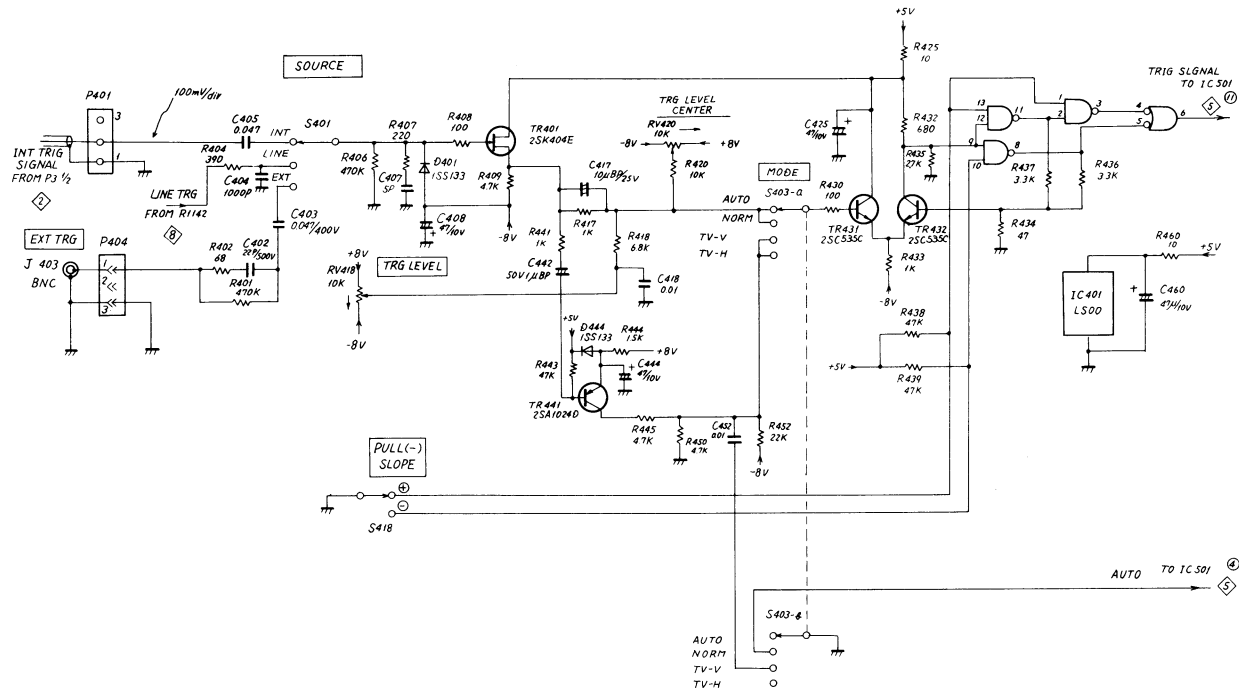

V-212  
TRIG GEN 4

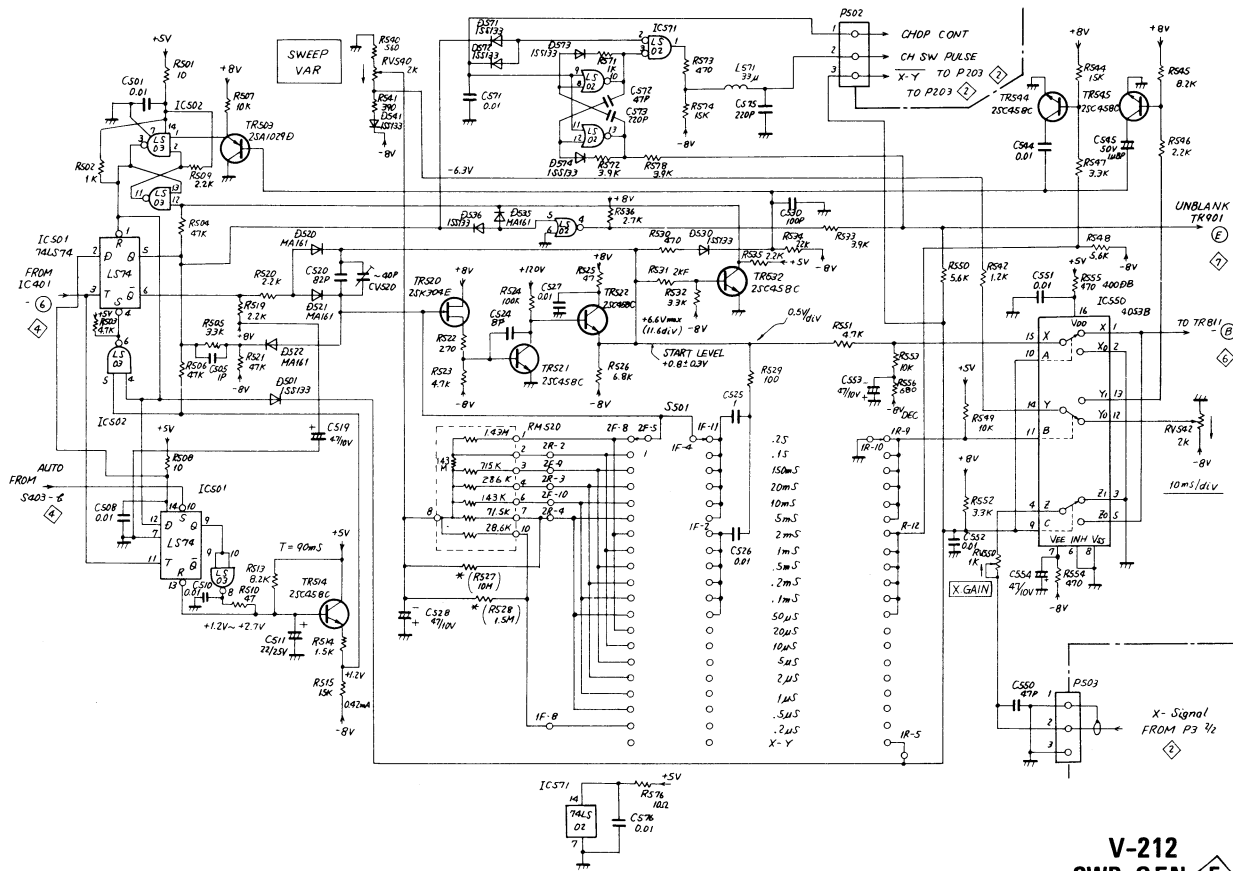

V-212  
SWP GEN 5







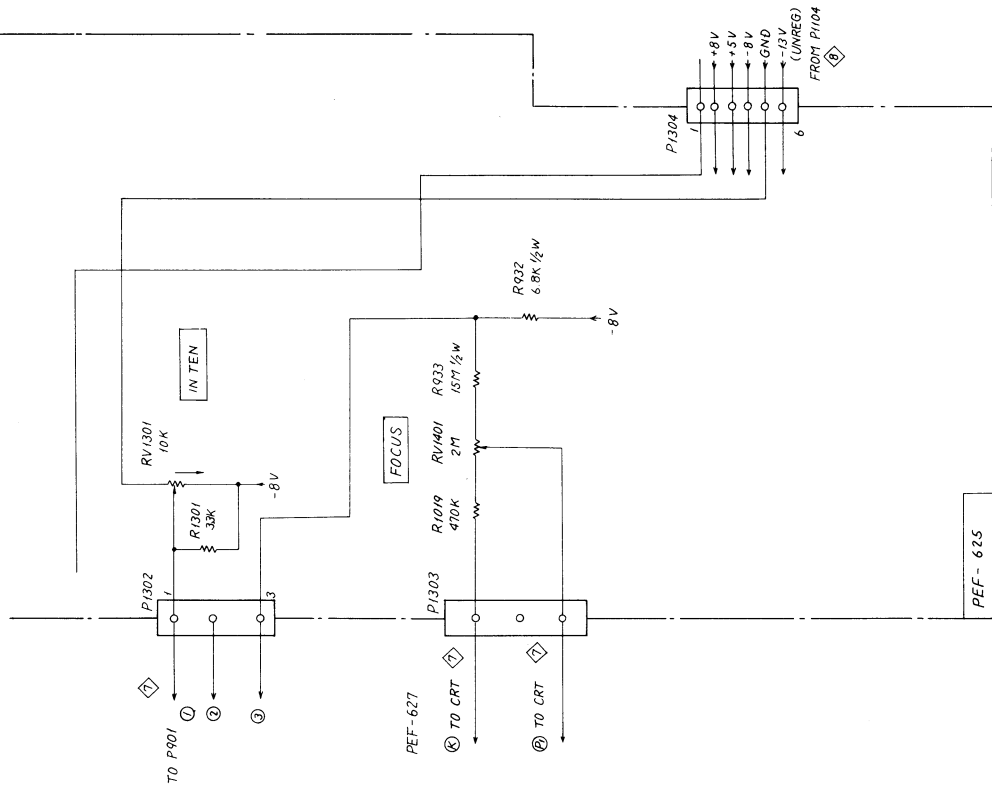

V-212  
RV/LAMP 

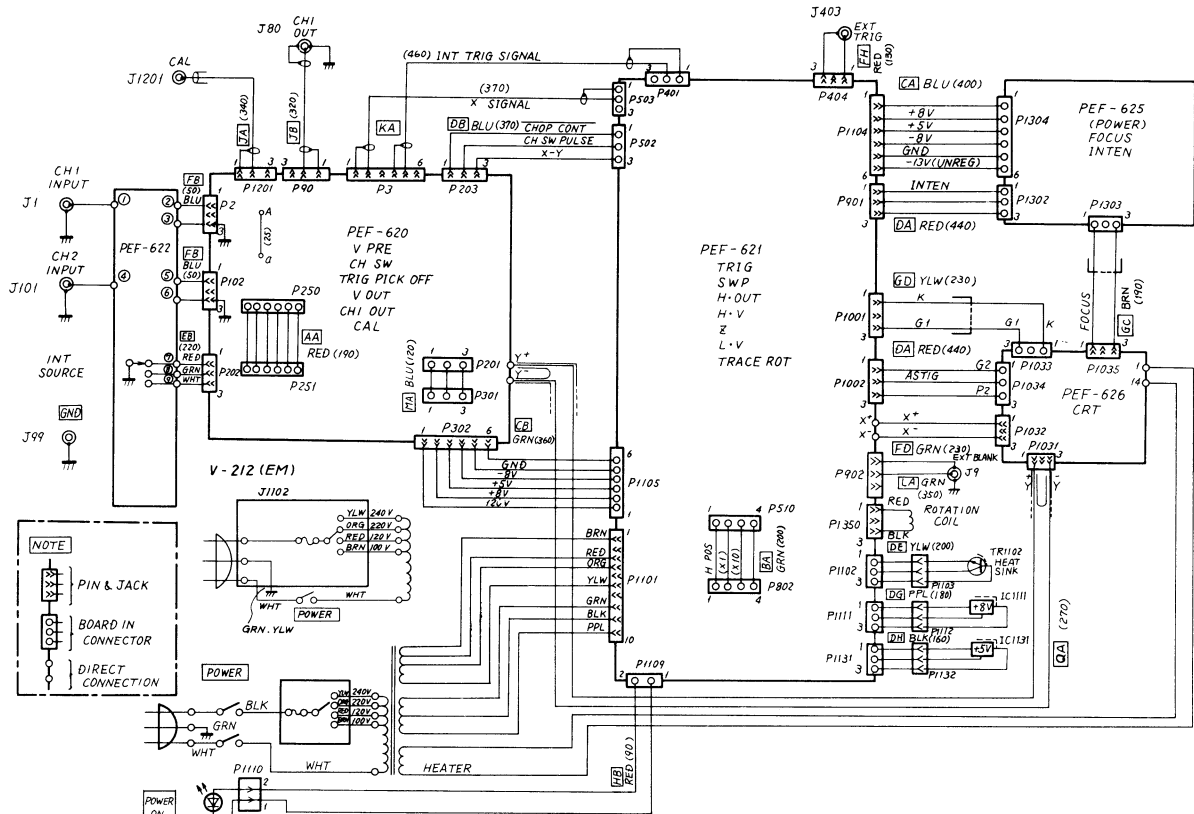

**V-212  
WIRING DIAGRAM**

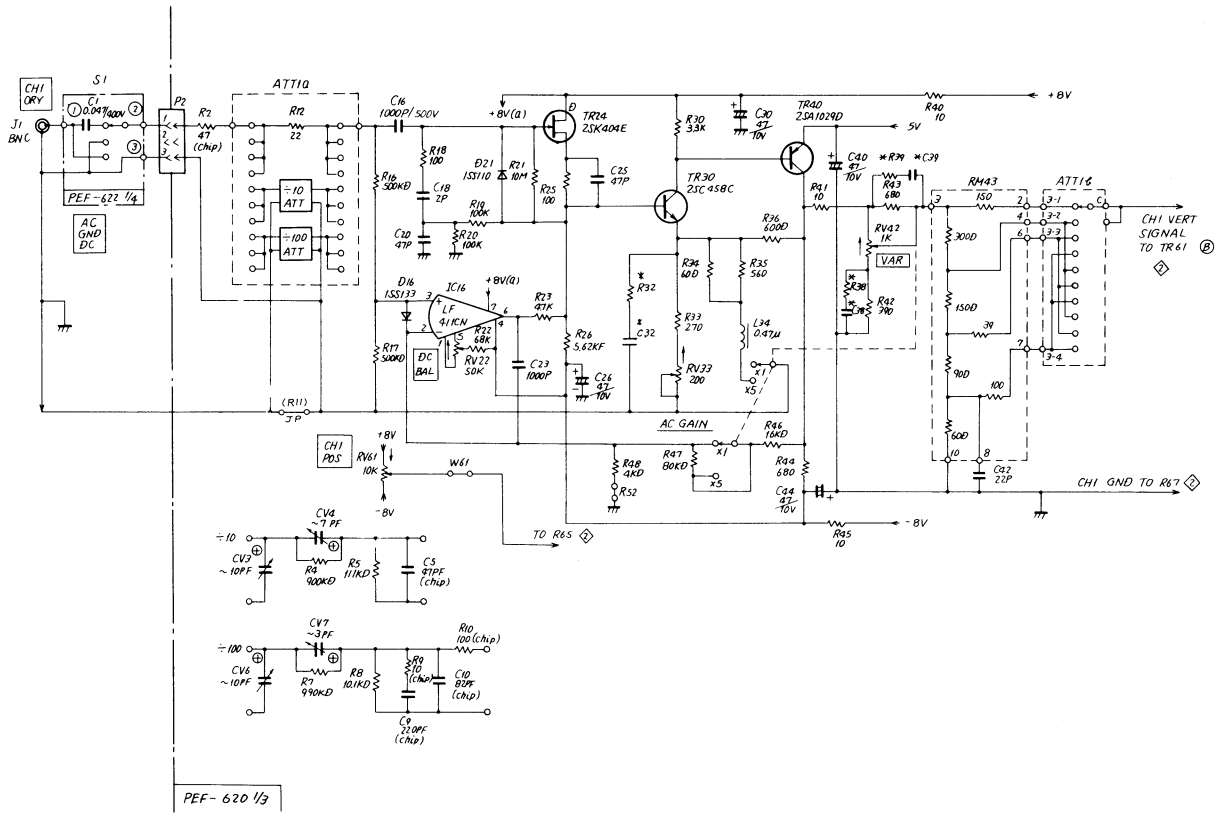

V-211  
INPUT AMP 1

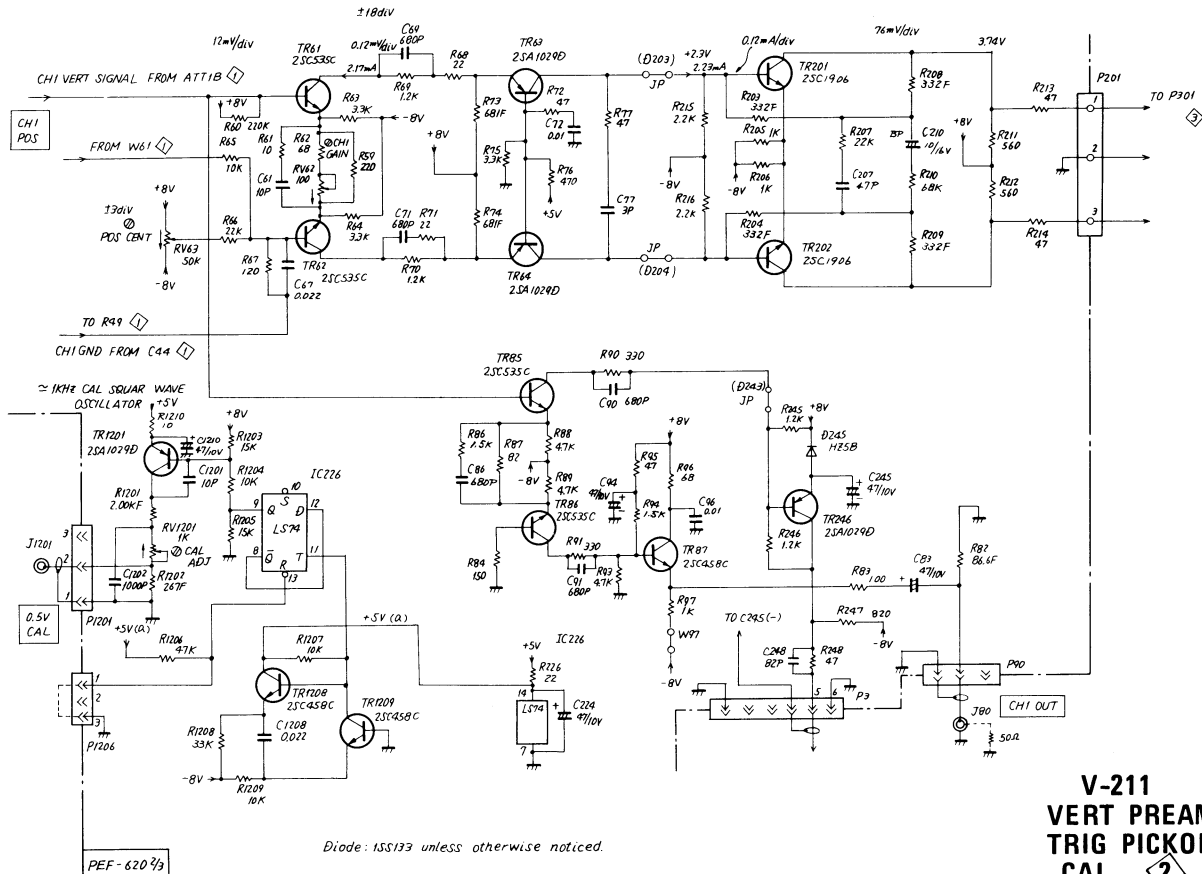

**V-211  
VERT PREAMP  
TRIG PICKOFF  
CAL**

2

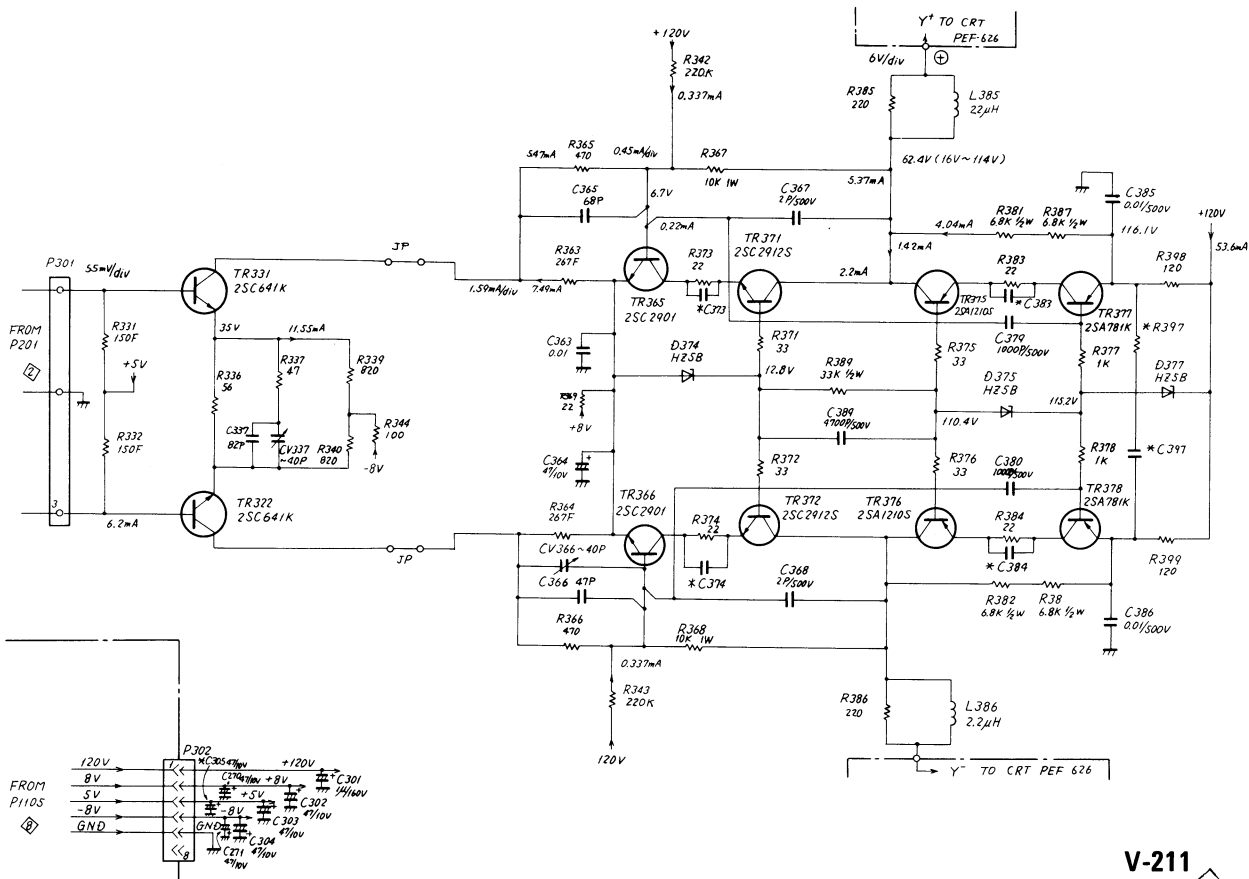

V-211  
V-OUT 3

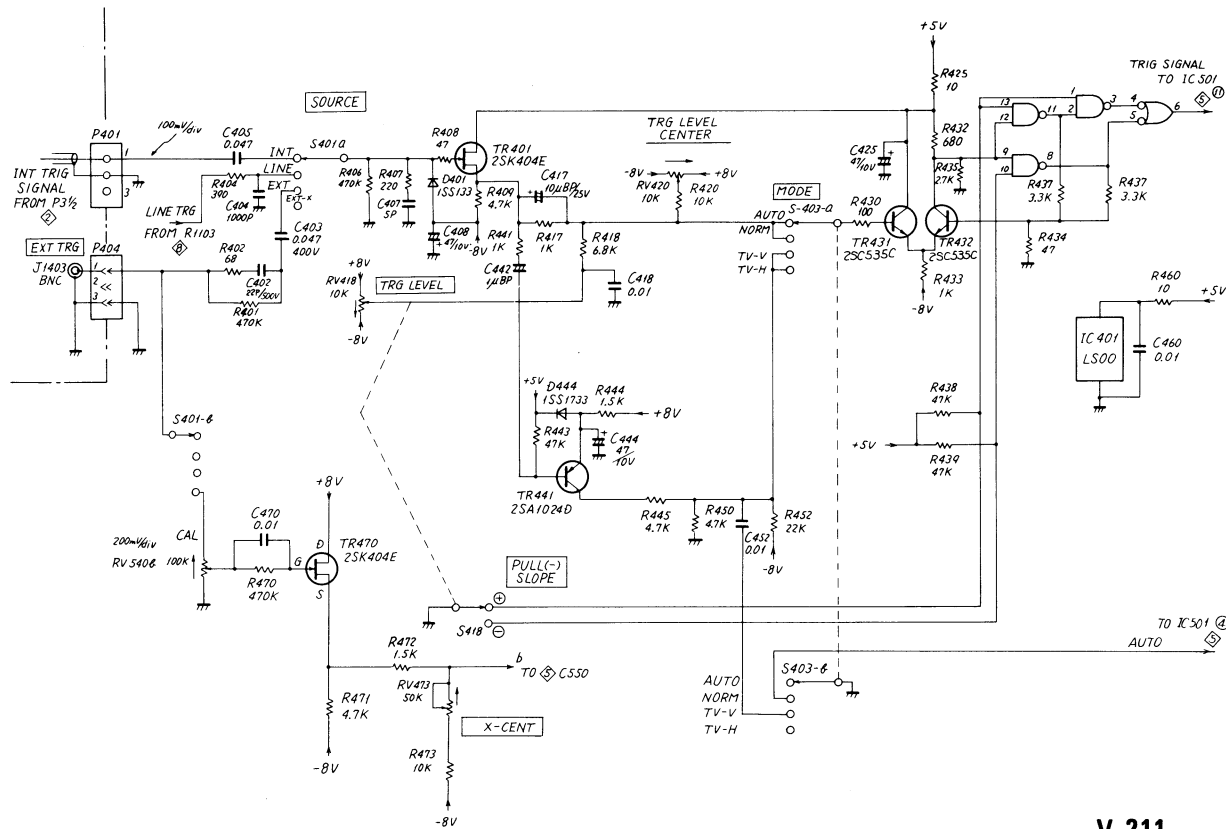

**V-211  
TRIG GEN 4**

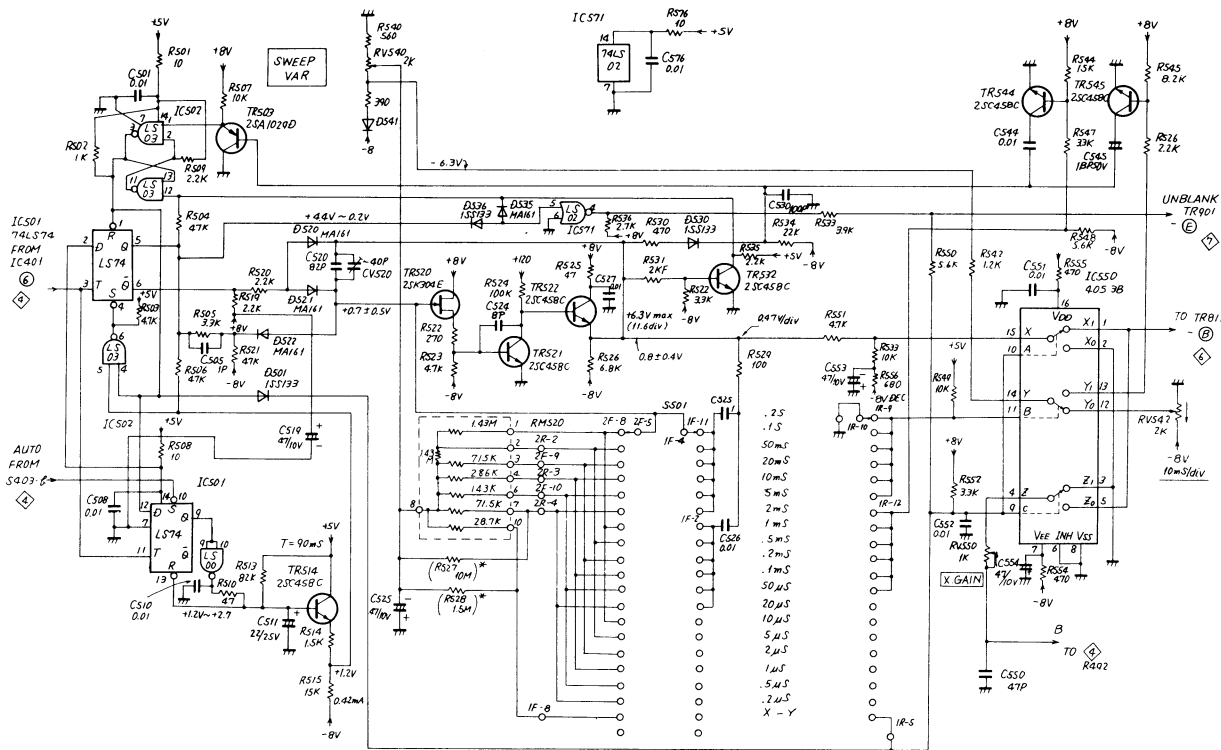

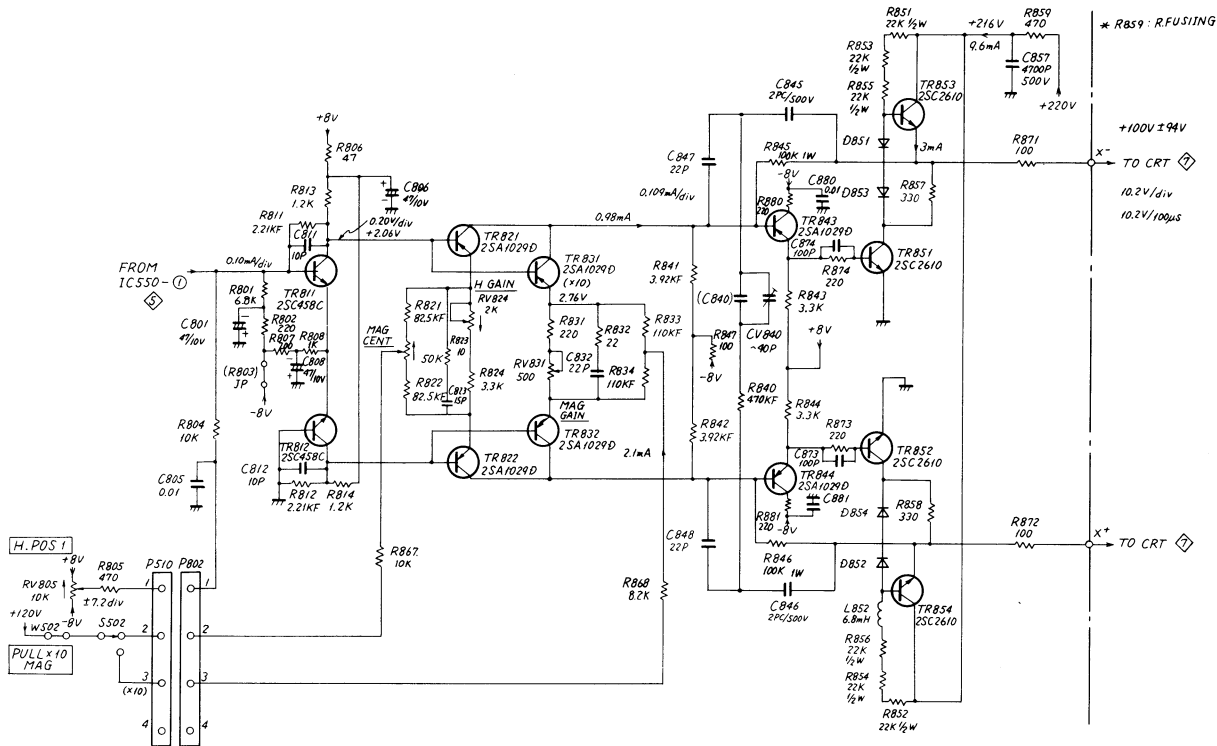

V-211  
H-AMP 





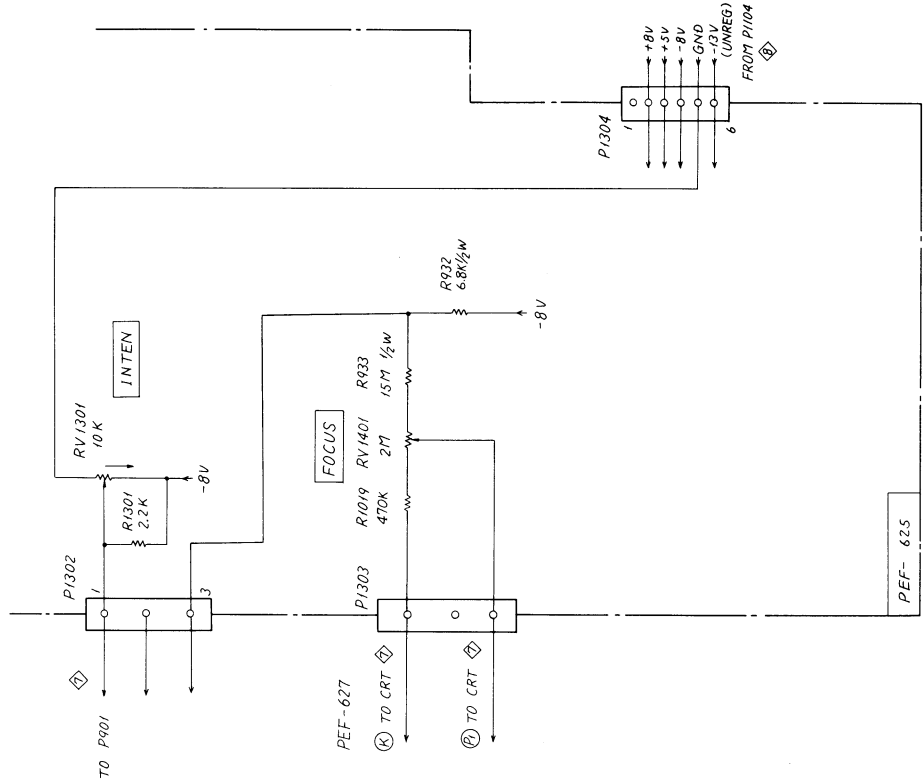

V-211  
RV/LAMP 9

