

# INSTRUCTIONS FOR USE

## LED-Thermometer

Part No.: 19 21 47

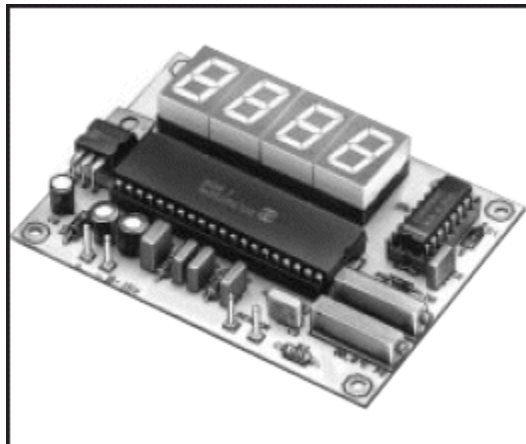

4 016138 192148



100%  
recycling  
paper

Bleached  
without  
chlorine

## Imprint

These instructions for use are published by Conrad Electronic GmbH, Klaus-Conrad-Straße 1, D-92240 Hirschau.

All rights including those of translations reserved. Reproduction of any kind e.g. photocopy, micro-filming, or entry in EDP systems requires a prior written permission of the publisher.

Reprinting, even in parts, is prohibited.

These instructions for use conform to the state-of-the-art technology at the time of printing.

Subject to changes in technology and equipment.

Reprint with the friendly permission of the magazine ELECTRONIC ACTUELL.

© Copyright 1998 by Conrad Electronic GmbH. Printed in Germany. \*344-01-99/05-MZ

# Important! Must read!

The warranty claim becomes null and void in case of damages arising out of non-adherence to the instructions for use. We do not assume any liability for consequential damages caused by this.

## Table of contents

	Page
Operating conditions.....	3
Intended use.....	5
Safety guidelines.....	5
Product description.....	7
Description of circuit.....	8
Technical data.....	11
General instructions for building a circuit.....	12
Soldering instructions.....	15
1. Construction stage I.....	17
Circuit diagram.....	25
Component diagram.....	26
2. Construction stage II.....	27
Checklist for troubleshooting.....	28
Equalisation.....	30
Fault.....	32
Warranty.....	32

## Note

Persons who produce a building kit or make an assembly operational through extending or fitting a casing are considered as manufacturers in accordance with DIN VDE 0869 and are committed to provide all accompanying papers when supplying the device and also to state his name and his address. Devices that are put together as assemblies are to be considered as an industrial product in accordance with technical safety regulations.

## Operating conditions

- The assembly may be operated only at the prescribed voltage.
- In case of devices with an operating voltage  $\geq 35$  volt the final assembly may be done only by an expert in accordance with the VDE-guidelines.

- The device can be operated in any position.
- The permissible ambient temperature (room temperature) may not fall short of or exceed 0°C and 40°C respectively during operation.
- The device is intended for use in dry and clean rooms.
- In case condensation takes place, an acclimatisation period of up to 2 hours must be given.
- It is not permitted to operate the device in the open or in wet rooms!
- It is advisable to cushion the component properly, in case it is subject to strong shocks or vibrations. However, please keep in mind that components can get heated up on the board and can cause fires, if a combustible material is used for cushioning.
- The device must be kept away from flower vases, bath tubs, washbasins and all liquids.
- Protect this component against moisture, splash water and effect of heat!
- The device may not be used together with easily inflammable and combustible liquids!
- Assemblies and parts should not fall in the hands of children!
- The assemblies may be made operational only under supervision of a competent adult or an expert!
- In industrial premises the accident prevention guidelines of the professional association of the specific industry for electrical systems and resources must be observed.
- In schools, educational institutions, hobby classes and self-help workshops the operation of the assemblies must be monitored by a trained person responsibly.
- Do not operate the assembly in an area, where combustible gases, vapours or dust is present or else can be present.
- Use only the original spare parts, if the device needs to be repaired! Use of any parts other than the original can lead to damage to property and person!
- The device may be repaired only by an expert!
- After use, the device must always be disconnected from the power supply!
- The device can be damaged, if a liquid penetrates in it. In case you have spilt any liquid in or over the assembly, then get the device checked by a qualified expert.

## **Intended use**

The intended use of the device is the measurement of temperatures with an external sensor in the range from -50° to +150° Celsius.

A use other than the intended one is not permitted!

# Safety Instructions

While handling the products that come in contact with electrical voltage the valid VDE-guidelines must be observed, especially VDE 0100, VDE 0550/0551, VDE 0700, VDE 0711 and VDE 0860.

- Before opening the device always pull out the plug or make sure that the device is completely without current.
- Components, assemblies or devices may be started up only when they have been fitted, completely insulated, in a casing. While fitting they must be completely devoid of current.
- Tools may be used on devices, components or assemblies only when it has been ensured that the devices have been disconnected from the power supply and electrical charges on the components present in the devices have been discharged.
- Live cables or lines, which are connected to the device, component or assembly, must always be checked for insulation faults or breaks. If a fault is ascertained in the supply line, the device must immediately be taken out of service till the defective cable has been replaced.
- When using electronic components or assemblies, the strict adherence to the characteristics for electrical variables given in the description must always be indicated.
- If the given description for the non-commercial end-user is not clear about the electrical characteristics applicable for the component or assembly, about how an external wiring is to be done or which external components or auxiliary equipment may be connected and what connected values these external components may have, then the required information must always be obtained from an expert.
- Before commissioning a device it must always be checked in general, whether this device or assembly is suitable for the application, for which it is intended to be used! In cases of doubt, please always ask the experts, the responsible persons or the manufacturer of the devices or assemblies used!
- Please note that connection or operational faults lie outside of our circle of influence. Understandably, we are not liable for damages caused by these reasons.
- If a component is not working, it must be returned with an exact description of the fault (specify what is not working... because only an exact description of the fault can enable a proper repair!), the related construction manual as well as without the casing. Understandably, we need to charge extra for assembling and dismantling work of the casing that require a lot of time. Components already mounted cannot be exchanged. In installations and when working with mains voltage, please always adhere to the VDE-guidelines.
- Devices that are operated at a voltage  $\geq 35$  V may be connected only by an expert.
- In each case it must be checked, whether the component is suitable and can be used for the respective application and location.
- The commissioning may be done only when the circuit has been installed properly insulated in a casing.

- If measurements are unavoidable with the casing open, then an isolating transformer must be interposed, or, as already mentioned, the power must be supplied through a suitable mains unit (that conforms to the safety regulations).
- All wiring work must be done in dead state.

## Product description

An electronic thermometer with 13 mm red LED-display. This thermometer can be used at all places, where temperatures are to be measured from  $-50^{\circ}\text{C}$  to  $+150^{\circ}\text{C}$  with a high degree of accuracy.

The use of the thermometer ranges from measuring the room temperature, outside temperature, flow and return of heating as well as in the car, caravan, boat, motor caravan, weekend home, laboratory, air-conditioning, industry, handicraft, and much more. With temperature sensor KTY 10.

**This article was checked according to EMVG (EG-Guideline 89/336/EMC/ Electromagnetic Compatibility), and the corresponding CE-certification mark was awarded.**

**Any change in the circuit or use of components other than the specified ones will make this certification null and void!**

## Description of circuit

In principle, such an electronic thermometer is nothing else but a digital voltmeter (DVM), which measures the changing voltage at a resistance divider. The circuit used for this, ICL 7107, is a controller for automatic DVMs with automatic zero-offset adjustment and display drivers.

The circuit manages with a simple, un-stabilised supply voltage, which can come from a wall power supply; the voltage regulator IC3 converts it into 5 V fixed voltage for IC1. The negative auxiliary voltage, required in addition, is generated with the help of an oscillator-cycle and CMOS-driver from IC2: These charge the electrolytic capacitor C1 to approx.  $-4\text{ V}$  via C2 and D2; this voltage spreads internally through IC1 intern and stabilises it.

IC1 has a separate driver with a steady-current output for each segment for controlling the LED-displays. This obviates the need for segment pre-resistors for current limitation and helps achieve a uniform brightness regardless of the voltage supplies from outside. Even the most significant point on the left can be equipped with a normal seven-segment display, even when at the most two segments are active here (either the '1' [starting from  $100^{\circ}\text{C}$ ] or the minus-sign [below  $0^{\circ}\text{C}$ ]).

The test signal is fed at the ICL 7107 via the connections 30 (earth side) and 31 (positive pole); capacitor C7 serves for short-circuiting the possible alternating current parts (e.g. spikes). The polarity of the voltage to be measured can be any, but must be done in the way described here; because only in this way the minus-temperatures get a negative sign that takes place through the following displacement:

In case of a normal digital voltmeter the reference point (common, pin 32), reference-minus (-ref, pin 35) and earth-side of the incoming signal (in I<sub>o</sub>, pin 30) are connected with one another. The polarity at the input 31 then decides the sign; it is positive if the connection 31 has positive potential vis-à-vis 30, otherwise it is negative.

However, since we are deriving here the voltage to be measured from the voltage divider R7/ KTY10, there are only positive signals. We displace the zero point by artificially laying “high” the measuring input 30 above the wiper of P2 (vis-à-vis the reference at 32 & 35).

The IC rates everything that lies below the artificial reference level at pin 30 as minus-signal and activates the negative sign. Since the voltage change at the temperature sensor takes place below and above the reference level, positive and negative measured values occur apparently. With reference to the connections 32 & 35 the voltage at pin 31 continues to be only positive. As you see, it is only a matter of how you look at it. We do the actual calibration of the scale through the setting of P1, which defines the exact reference voltage at pin 36.

Despite the good linearization a residual error continues to exist in the sensor characteristic, which adds up to a little more than 2% with the tolerance in the pre-resistor R7 (at the area boundaries). This is – with respect to the total effort – a very good accuracy, the more so as the measurement error in the middle range approaches almost zero (can be adjusted with the P1-setting).

These considerations are crucial for the fact that there is no need to make an exaggerated effort in case of critical components of the voltmeter (capacitors for the zero-offset and the integrator) (standard types suffice). The deviations caused as a result of this go down in system errors. On the other hand, metal-film resistors are to be used for R5 and R7 and spindle potentiometers for P1 and P2.

Pay attention to the correct polarity in case of diodes and electrolytic capacitors: The cathode-side (black ring) points away from IC1 in case of rectifier diode D2, away from C2 in case of D1 and towards IC1/IC3 in case of D3. Contrary to the usual, the positive pole is at the earth in case of electrolytic capacitor C1 (it buffers the negative auxiliary voltage). Use those sockets for IC1 and IC3, whose marking notch can be aligned in the same way as in IC, which these are supposed to accept; even the four displays use a 40-pin socket.

Most of the ICs have their contact pins spread towards outside, so that they do not fall out again after an automatic mounting; however, they can be bent again towards one another by applying a slight pressure against a surface.

After mounting and a visual check for any soldering or mounting faults, you can carry out two broad functional checks: Connect at bottom left a voltage of approx. 7...18 V and measure at the right connection of IC3, whether +5 V (against earth) is present there. At the anode of D2 (left) a voltage of approx. -4 V must be present (against earth), if everything works well, and random values appear in the display.

Owing to the displaced zero point, the basic setting cannot be done in case of short-circuit on the input side, but instead must be done at “real” zero degree Celsius. This can be achieved very easily by filling a glass of water with ice (crushed cubes) for so long, till the ice no longer melts even after stirring for a long time. In a saturated mixture of ice and water a temperature of exact 0°C gets set, because each supply of heat (from the environment) does not raise the temperature, but instead is used first for melting the floating ice; only after that the temperature of water starts rising.

Insert the sensor in a thin pipe and immerse both in the ice solution, in order to conduct the zero offset with P2. Thereafter, look for a (plus-) reference temperature e.g. near the huge thermometer of an optician's shop, and set this reference with P1. the more exact

the reference value and the offset are, the lower will be the error; in the ideal case it is zero (but only at this reference temperature!).

## Technical data

**Operating voltage.....: 7 ... 18 V=**  
**Power consumption.....: approx. 200 mA**  
**Measurement range.....: -50.0 to +150.0°C**  
**Resolution.....: 0.1°C**  
**Display.....: 3½ -digit, 13 mm LED-display, red, with minus sign**  
**Dimensions.....: 85 x 63 mm**

## Caution!

Before you start with the assembly, please read these guidelines completely till the end, before you start-up the component or the device (please read especially the section on possible errors and their removal!) and naturally also the safety instructions. You will then know what is important and to what you need to pay attention, in order to avoid faults, which can be removed later only with a high effort!

Carry out the soldering and wiring absolutely cleanly and diligently, do not use any soldering tin containing acid, soldering grease, etc. Make sure that no cold solder joint is present. An unclean soldering or a poorly done solder joint, a loose contact or a poorly done assembly imply an extensive and time-consuming search for faults and sometimes also a destruction of the components, which can often entail a chain reaction and destroy the complete kit.

Also keep in mind that we will not repair the kits that have been soldered with the help of acid-containing soldering tin, soldering grease, etc. While assembling electronic circuits a fundamental knowledge of handling the components, soldering and handling of electronic or electrical parts is required.

## General instructions for making a circuit

The possibility that something does not work after the assembly can be reduced drastically through an assembly done cleanly and diligently. Check each step, each solder joint twice, before you proceed! Follow the assembly instructions! Do not carry out the step described there in a different way and do not skip anything! Put a double tick-mark on each step: once for assembly and once for checking.

Take your time: Tinkering is not a piece-work, because the time spent here is three-times less than that spent in looking for faults.

A frequent reason for a non-functioning component is a mounting error, such as incorrectly inserted components like ICs, diodes and electrolytic capacitors. Please also pay attention to the colour rings of the resistors, since most of them have colour rings that can be mixed up easily.

Pay attention to the capacitor values e.g. n 10 = 100 pF (not 10 nF). Checking twice and thrice can help here. Also see to it that all the IC contacts are actually inserted in the socket. It can happen very easily that one of these gets bent during insertion. A slight pressure and the IC must go in the socket all by itself. If this does not happen, then probably one of the contacts is bent.

If everything is OK here, then the next place to look for a possible fault is a cold solder joint. These unpleasant things while tinkering occur when either the solder point was not heated properly, so that the tin comes properly in contact with the cables, or when the joint was moved while cooling at the time it was just setting. Such faults can mostly be detected at the matt-look of the surface of the solder joint. The only solution here is to solder the joint once again.

90% of the reclaimed kits have soldering faults, cold solder joints, incorrect soldering tin used, etc. Many a returned “masterpieces” bear witness to improperly done soldering. Therefore, use only the electronic soldering tin “SN 60 Pb” (60% tin and 40% lead) for soldering. This soldering tin has a colophony core, which acts as soldering flux, in order to protect the soldering joint from being oxidised during soldering. Other soldering fluxes like soldering grease, soldering paste or soldering fluid may not be used in any case, because they contain acids. They can damage the printed circuit board and the electronic components; moreover, they also conduct electricity and thereby cause leakage currents and short-circuits.

If everything is okay till this point and the circuit still does not work, then probably a component is defective. If you are an electronics amateur, then it is the best for you to consult a known person, who is well-versed with electronics and has the necessary measuring equipment.

If you do not have this option, then return the kit properly packed to our service department along with an exact description of the fault as well as the related assembly instructions (only an exact description of the fault will enable a proper repair!). An exact description of the fault is important, because the fault can also lie in your mains supply or in your external wiring.

## Note

Before going in production, this kit was built and tested several times as prototype. It was released for serial production only when an optimum quality was achieved with respect to function and operational safety.

The entire assembly is classified in two construction stages, in order to ensure a certain functional safety while building the system:

### **1. Construction stage I: Mounting the components on the board**

### **2. Construction stage II: Functional test**

While soldering the components see to it that they (unless indicated otherwise) are soldered on to the plate without any gap. All projecting connection wires are cut directly above the solder joint.

Since the solder points in this kit are very small ones, lying partly very close to one another (risk of solder straps), the soldering must be done here only with a soldering iron with a small soldering tip. Do all the soldering and assembly work very carefully.

## Soldering instructions

If you do not have much practice in soldering, then it is advisable to go through these soldering instructions before you actually start soldering. Soldering must be learnt.

1. Never use soldering grease or soldering fluid when soldering electronic components. These contain acids, which can damage the components and conducting paths.

2. Only electronic tin SN 60 Pb (i.e. 60% tin, 40% lead) with a colophony core may be used as soldering material, which at the same time also acts as soldering flux.
3. Use a small soldering iron with max. 30 watt heating power. The soldering tip should be tinder-free, so that the heat can be discharged properly. This means: The heat from the soldering iron must be conducted properly to the point to be soldered.
4. The soldering itself should be done quickly, because a longer duration of soldering can damage the components. Similarly, it also leads to release of eyelets or copper pathways.
5. For soldering the properly tinned soldering plate is kept on the point to be soldered in such a way that it touches the component wire and the conducting pathway at the same time.

Simultaneously, soldering tin (not very much) is added, which also gets heated up. As soon as the soldering tin starts to flow, take it away from the solder joint. Then wait for a moment, till the solder left behind has blended properly and then remove the soldering iron from the solder joint.

6. See to it that the component you have just soldered is not moved for approx. 5 seconds after you remove the soldering iron. What remains after that is a silvery shining, smooth solder joint.
7. A prerequisite for a smooth solder joint and good soldering is a clean, non-oxidised soldering tip. With a dirty tip it is absolutely not possible to do a clean soldering. Therefore, after every soldering, wipe away the extra soldering tin and dirt with a damp sponge or with a silicone wiper.
8. After soldering the connection wires are cut directly above the solder joint with a wire cutter.
9. When soldering semi-conductors, LEDs and ICs special attention must be paid to the fact that the soldering time does not exceed approx. 5 seconds, as otherwise the component gets destroyed. Similarly, attention must also be paid to the correct polarity in case of these components.
10. After mounting, check each circuit once again to see that all components are inserted correctly and polarised. Also check, whether the connections or conducting pathways have not been bridged by mistake with tin. This can not only lead to faulty functioning, but also to a damage of the expensive components.
11. Please note that improper solder joints, false connections, improper usage and mounting faults are outside of our influence.

## **1. Construction stage I:**

### **Mounting the components on the printed circuit board**

#### **1.1 Resistors**

First, the connection wires of the resistors are bent at right angles conforming to the contact spacing and inserted in the openings provided (as per the component diagram). In order that the components do not fall out when the board is turned over, bend the connection wires of the resistors away from one another at an angle of approx. 45°, and then solder them carefully with the conducting pathways on the rear side of the printed circuit board.

Thereafter, the excess wires are cut away.

Note that this circuit is equipped with two different types of resistors.

The commonly used resistors are the carbon film resistors. They have a tolerance of 5% and are marked by a gold-coloured "tolerance ring".

Carbon film resistors normally have four coloured rings.

Metal film resistors have a tolerance of just 1%. This is shown by a brown "tolerance ring", which is imprinted a little broader than the remaining four colour rings. This is meant to avoid a confusion with a normal "value ring" having the value of "1".

For reading the colour code the resistor is held in such a way that the coloured tolerance ring is present to the right of the body of the resistor. The coloured rings are then read from left to right!

R1 = 100 k	brown, black, yellow	
R2 = 100 k	brown, black, black, orange	(metal film)
R3 = 470 k	yellow, violet, yellow	
R4 = 680 R	blue, gray, brown	
R5 = 1 M	brown, black, black, yellow	(metal film)
R6 = 100 k	brown, black, black, orange	(metal film)
R7 = 5,6 k	green, blue, black, brown	(metal film)



## 1.2 Diodes

Now, the connection wires of the diodes are bent at right angles conforming to the contact spacing and inserted in the openings provided (as per the component diagram). Always see to it here that the diodes are inserted in a correctly polarised way (position of the cathode line)!

In order that the diodes do not fall out when the printed circuit board is turned over, bend the connection wires away from one another by approx. 45° and solder them with the conducting pathways in a short soldering time. Thereafter, the projecting wires are cut away.

D1 = 1 N 4148	Silicone universal diode
D2 = 1 N 4148	Silicone universal diode
D3 = 1 N 4001, 4002 or 4003	Silicone power diode

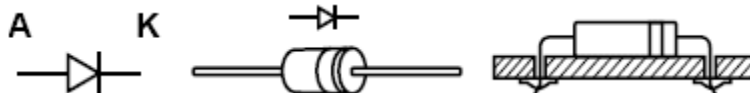

## 1.3 Capacitors

Insert the capacitors in the holes marked correspondingly, bend the wires a little away from one another and solder them cleanly with the conducting pathways. In case of electrolytic capacitors pay attention to the correct polarity (+ -).

# Caution!

Depending upon their make the electrolytic capacitors show different polarity markings. Some manufacturers mark “+”, others “-“. The polarity specification printed by the manufacturer on the electrolytic capacitor is important.

C1 =	10 $\mu$ F			Electrolytic capacitor
C2 =	47 nF	= 0,047 $\mu$ F	= 473	Film capacitor
C3 =	100 pF	= n 10	= 111	Film capacitor
C4 =	0,1 $\mu$ F	= 100 nF	= 104	Film capacitor
C5 =	47 nF	= 0,047 $\mu$ F	= 473	Film capacitor
C6 =	0,22 $\mu$ F	= 220 nF	= 224	Film capacitor
C7 =	0,1 $\mu$ F	= 100 nF	= 104	Film capacitor
C8 =	47 $\mu$ F			Electrolytic capacitor
C9 =	47 $\mu$ F			Electrolytic capacitor

## 1.4 IC-sockets

Insert the sockets for the integrated circuits (ICs) as well as for the LED-displays in the corresponding positions on the assembly side of the printed circuit board.

# Caution!

Pay attention to the indentation or any other such marking on the front side of the socket. This is the marking (connection 1) for the ICs that are to be used later. The sockets must be inserted in such a way that this marking matches the marking at the printed side of the board!

In order to prevent the sockets from falling out when the printed circuit board is turned over (for soldering), every two pins of the socket lying diagonally opposite to each other are bent and thereafter all the contact pins are soldered.



## 1.5 Soldering pins

Press the soldering pins (for connecting the operating voltage and sensor) with the help of flat-nose pliers from the assembly side in the holes marked accordingly. Thereafter, the pins are soldered on the side with the conducting pathways.



## 1.6 Spindle-trimmer potentiometer

Solder now both the spindle-trimmer potentiometers in the circuit.

P1 = 100 k

P2 = 100 k

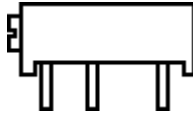

## 1.7 LED seven-segment displays

Set the LED-displays in the 40-pin IC-socket.

See to it that each of the decimal points are below.

LD1 = D 350 PA, TDSR 5150, SL 1119, LTS 546 AP, 0S-516 HWA or the like

LD2 = D 350 PA, TDSR 5150, SL 1119, LTS 546 AP, 0S-516 HWA or the like

LD3 = D 350 PA, TDSR 5150, SL 1119, LTS 546 AP, 0S-516 HWA or the like

LD4 = D 350 PA, TDSR 5150, SL 1119, LTS 546 AP, 0S-516 HWA or the like

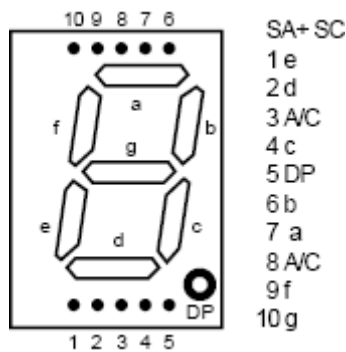

## 1.8 Voltage regulator

The integrated voltage regulator (after bending the contact pins) is now inserted in the openings provided and the contact pins are soldered on the soldering side.

Pay attention to a short soldering time, so that the voltage regulator is not destroyed by overheating.

IC3 = 7805 TO 220

(Inscription must  
be readable)

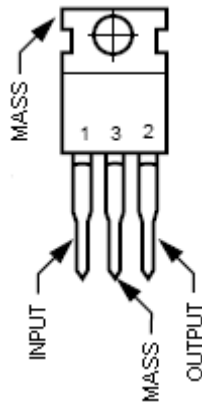

## 1.9 Integrated circuits (ICs)

Finally, the integrated circuits are inserted in the openings provided with the correct polarity.

### Caution!

Integrated circuits are very sensitive to incorrect polarity! For this reason, pay attention to the corresponding marking on the ICs (notch or point).

The component IC 2 is an especially sensitive CMOS-IC, which can be destroyed through static charge.

MOS-components should thus be gripped only at the casing, without thereby touching the contact pins.

Integrated circuits should not be changed or inserted in the socket if the operating voltage has been applied.

IC1 = ICL 7107, marking (notch or point) must point to "R2"

IC2 = CD 4049, HCF 4049 or MC 14049, marking (notch or point) must point to "D2".

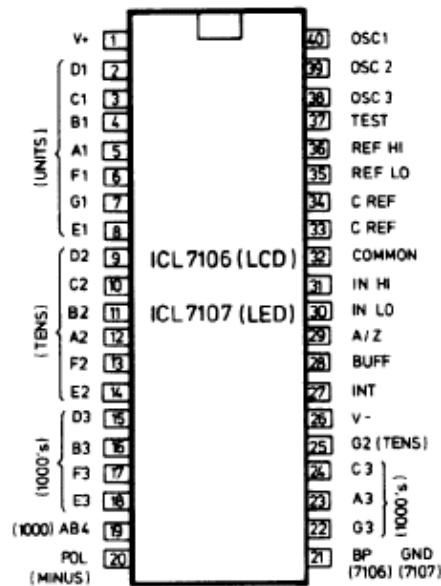

07 A/D-converter 3½ digit

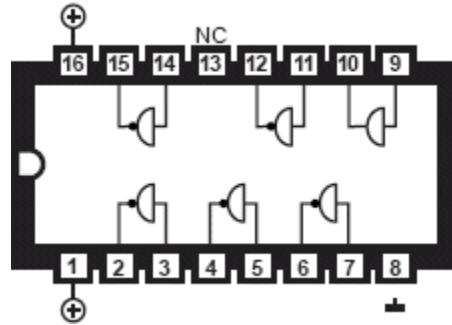

## 1.10 Final check

Before starting-up, check the printed circuit board once again that all the components have been inserted properly and with the correct polarity. Check on the soldering side (the side with the conducting pathways), whether the conducting pathways have been bridged by the remains of the soldering tin, which can lead to short-circuits and to a destruction of the components.

Further, it must be checked whether the cut wire-ends are lying on or below the printed circuit board, which can also lead to short-circuits.

Most of the components sent back for a reclaim have poorly soldered connections (cold solder joints, solder straps, incorrect or unsuitable soldering tin used, etc.).

## Circuit diagram

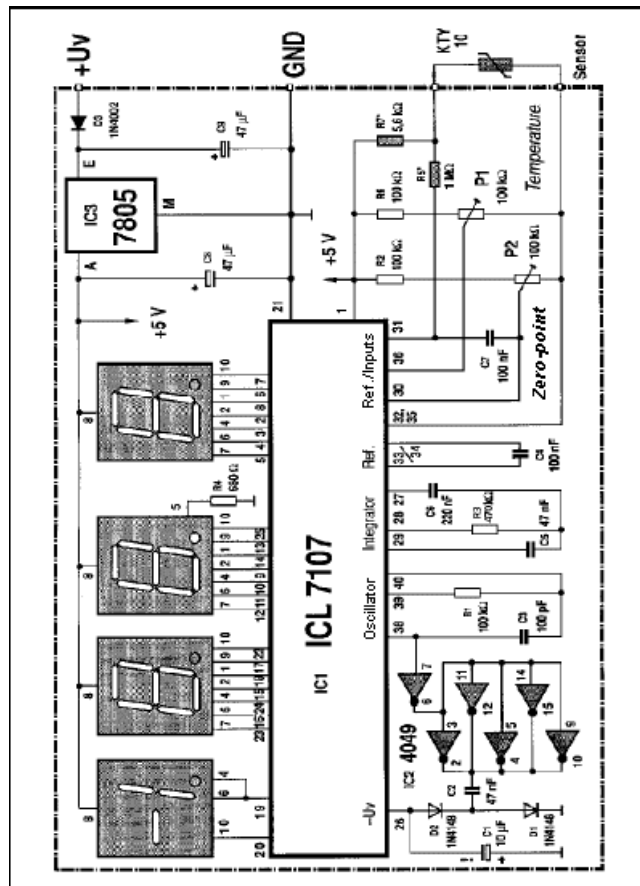

## Component diagram

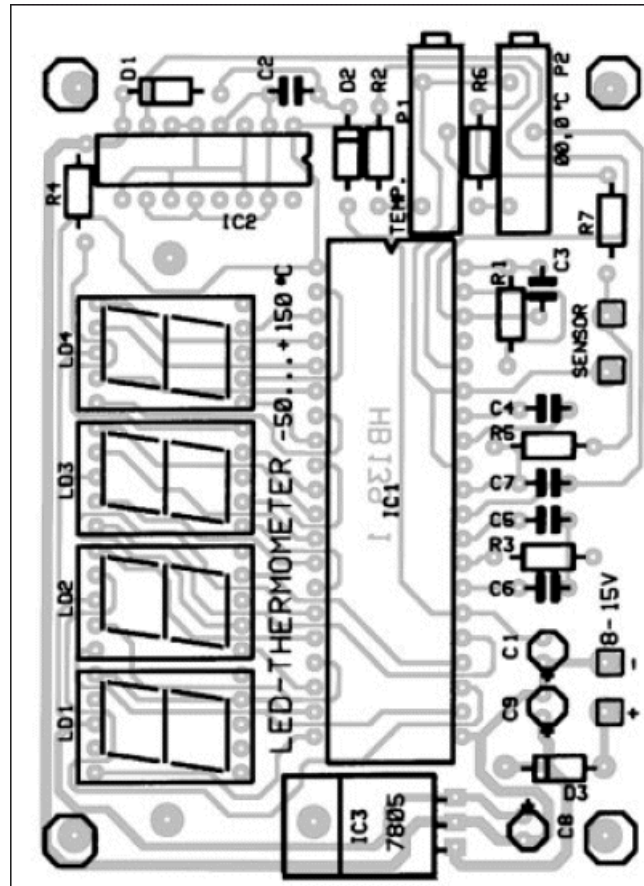

## 2. Construction stage II:

### Connection/start-up

- 2.1 After the components have been placed on the printed circuit board and the board has been checked for possible faults (cold solder joints, solder straps, etc.), a first functional test can be conducted.
- 2.2 Bring both the trimmer potentiometers in the middle position.
- 2.3 Note that this component may be powered only with a screened direct current from a power supply unit or with a battery, which can also provide the necessary current. Car chargers or toy-railway transformers are not suitable sources of power and can cause damage of the components or else can lead to a non-functioning of the assemblies.
- 2.4 Solder now the temperature sensor (KTY 10 = KTY 81/220 B) at the attachment shoes by means of a piece of cable and attach these on the solder pin marked as "sensor". The sensor can have any polarity. In order to protect the sensor connections against moisture, the sensor should be covered with a shrink tubing.

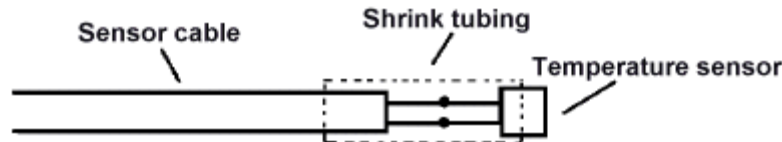

- 2.5 A screened direct voltage of approx. 7 – 18 V= is applied to the solder pins marked with “+” and “-”. It must be noted that the power supply unit used must conform to VDE-regulations.
- 2.6 Depending upon the wiper setting the spindle-trimmer will be pointing to some temperature.
- 2.7 If the 7-segment displays do not glow as expected or if the equalisation described below cannot be done or else any other function is not possible, then immediately cut off the operating voltage and check the complete printed circuit board once again according to the checklist given below.

## Checklist for fault search

### Cross out each step!

- Has the correct operating voltage been set?
- Is the polarity of the operating voltage correct?
- Are the 7-segment displays inserted correctly in the sockets? Decimal points must point in the downward direction (in the direction of IC1).
- Have the resistors been soldered correctly in terms of value? Check the values once again in accordance with 1.1 of the construction guidelines.
- Have the diodes been soldered with the correct polarity? Does the cathode ring placed on the diode match with the imprint on the printed circuit board?  
The cathode ring of D1 must point away from C2.  
The cathode ring of D2 must point away from IC1.  
The cathode ring of D3 must point to IC3/IC1.
- Have the electrolytic capacitors been polarised correctly? Compare the polarity printed on the electrolytic capacitors “+” or “-” once again with the print on the circuit board or in the component diagram in the construction manual. Note that depending upon the make, “+” or “-” can be marked on the electrolytic capacitors!
- Have the integrated circuits been inserted in the sockets with the correct polarity?  
Notch or point of IC1 must point to R2.  
Marking of IC2 must point to D2.
- Are all the IC-contact pins really inserted in the socket? It can happen very easily that a contact pin gets bent or skids past the socket while inserting.
- Is there a solder strap or a short-circuit present on the soldering side? Compare the connections of the conducting paths, which possibly look like an unintended solder strap, with the diagram (grid) of the printed circuit board and the circuit diagram in the instructions, before you break a conductor (supposed solder strap)!
- To be able to easily ascertain the conductor paths or conductor breaks, hold the soldered printed circuit board against light and look for these unwanted side-effects from the soldering side.

- ❑ Is a cold solder joint available? Please check each solder joint thoroughly! Check by using a pair of pincers, whether the components are wobbling! If you suspect a solder joint, then solder it again to be on the safe side!
  - ❑ Also check that each joint is soldered; it often happens during soldering that joints are overlooked.
  - ❑ Also keep in mind that a printed circuit board soldered with soldering fluid, soldering grease or inappropriate soldering tin cannot function. These substances conduct electricity and thereby cause creep currents and short-circuits. Furthermore, the warranty of the components soldered with acidic soldering tin or similar materials becomes null and void and we can then no longer repair or replace these components.
- 2.8** If all these points have been checked and faults, if any, have been removed, then connect the printed circuit board again as per the instructions given in **2.3**. If no component has been damaged through a possibly available fault, the circuit must work now.

The present circuit can now be commissioned after a successful functional test and installation in a corresponding casing, under observation of the VDE-guidelines for the intended use.

## Equalisation

- 2.9** The equalisation of the circuit is now done at 0°C and 100°C.
- 2.10** For equalising the zero-point the sensor is held in ice-water and the display is set to "00.0" with the help of the spindle-trimmer P 2.  
To do this, a glass of water is filled to half with crushed ice cubes, a little water is added, till about half the height of the ice cubes is covered with water. Insert the sensor now in the middle of ice, wait for a few minutes and then set the display to exactly "00.0" with the help of the spindle trimmer.
- 2.11** For equalising the temperature (100°C or 36.9°C) two different possibilities can be selected:
1. Equalisation with the clinical thermometer
  2. Equalisation with boiling water

### Possibility 1:

To start with, one measures his body temperature by placing a normal clinical thermometer in the mouth. The temperature of a healthy human being is about 36.9°C. After a few minutes the thermometer is taken out of the mouth and the indicated temperature is read. Thereafter, the temperature sensor, cleaned beforehand, is taken in the mouth and after a few minutes the temperature read with the clinical thermometer is set to 36.9 °C with the help of a spindle-trimmer (P 1).

### Possibility 2:

In this possibility, one makes use of the fact that boiling water has a temperature of 100°C, which fluctuates only negligibly with the atmospheric pressure (can be ignored). The sensor is now immersed in a vessel with boiling water (must be bubbling properly), whereby one must be careful that neither the sensor nor the connecting cable touches the floor or the wall of the vessel. After a few minutes the display is set to "100.0" with

the help of P1, and the equalisation thus comes to an end. In order to achieve the maximum accuracy, the 0° and 100°C equalisation must be repeated.

The selection of the equalisation method also depends upon the later use. For instance, if temperatures are to be measured mainly in the living area (below 50°C) the method with the clinical thermometer is more appropriate, because it covers these temperatures in a better way. If temperatures above 50°C (0°...100°C) are to be measured more frequently, the boiling water method is to be preferred.

## **Fault**

If it can be assumed that a safe operation is no longer possible, then the device must be taken out of service and safeguarded against unintentional use.

### **This is applicable:**

- when damages are visible on the device
- when the device is no longer functional
- when parts of the device have become loose
- when the connecting cables show visible damages.

**In case the device needs to be repaired, then only the original spare parts must be used! The use of spare parts other than original can lead to serious damage to property and injuries to persons!**

**The device may be repaired only by an expert!**

## **Warranty**

This device comes with a warranty of 1 year. The warranty includes the free removal of faults, which can be traced back to the use of improper materials or manufacturing defects.

Since we have no influence on the correct and proper assembly, we can understandably give warranty only for the completeness and the perfect condition of the components.

A functioning of the components in the uninstalled state corresponding to the characteristics and the adherence of the circuit to the technical data in case of proper and prescribed commissioning and operation in accordance with the soldering guidelines is guaranteed.

Another other claims are ruled out.

We assume neither a warranty nor any kind of liability for damages or consequential damages caused in the context of this product. We reserve the right to repair or improve the device, deliver the spare parts or refund the purchase price.

No repair will be done and the warranty claim will become null and void in case of the following:

- if soldering tin containing acid, soldering grease or acidic soldering flux etc., has been used for soldering,
- if the component has been soldered or assembled in an improper or unprofessional way.

### **The same is also true**

- in case of attempts to change or repair the device

- in case of arbitrary changes in the circuit
- in case of improper placement of components not intended in the design, free wiring of components like switches, potentiometers, sockets, etc.
- in case of use of other components not originally belonging to the kit
- in case of destruction of conducting paths or soldering eyes
- in case of incorrect equipping and the consequential damages resulting from this
- in case of overloading of the module
- in case of damages caused by interventions through external persons
- in case of damages caused by a non-adherence to the installation instructions and the connection plan
- in case of connection to an incorrect type of voltage or current
- in case of incorrect polarity of the modules
- in case of incorrect usage or damages caused by negligent handling or misuse
- in case of defects caused by bridged fuses or through the use of false fuses

In all these cases the return of the component will be to your account.