

Model Number: XT25BG60-04
Description: 25mm,4ohm,tweeter

Revision: rev 1_0
Date: 6-Nov-09



The goal for this tweeter series was to create a transducer that has a frequency response that is flat to above 20K, and where the distortion is far lower than normal and more friendly to the ear. The tweeters represent a unique approach to tweeter design that has resulted in unrivaled performance, as well as in several patents (Dual Ring Radiator diaphragm, wave-guide center plug).

Driver Highlights: Dual Ring Radiator diaphragm (Patent), waveguide center plug (Patent), copper-clad aluwire



Mechanical 2D Drawing:

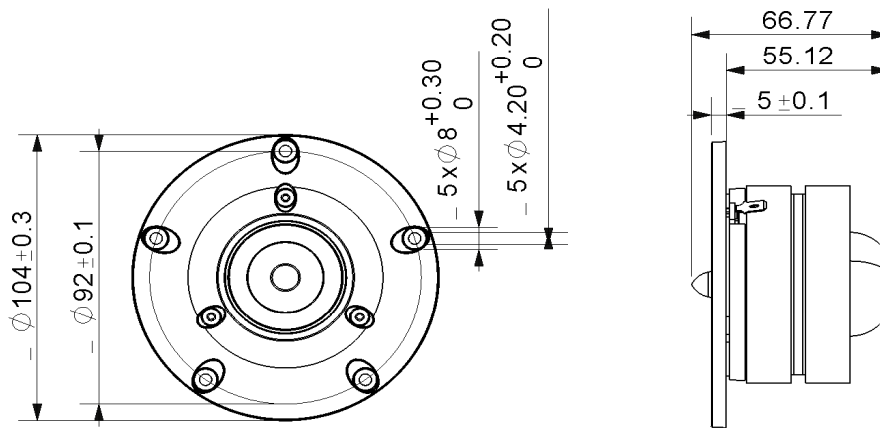

Specifications:

DC Resistance	R_{vc}	Ω	3.0	Energy Bandwidth Product	EBP	$(1/Q_{es}) \cdot f_s$	1375
Minimum Impedance	Z_{min}	Ω	3.4	Moving Mass	M_{ms}	g	0.36
Voice Coil Inductance	L_e	mH	0.01	Suspension Compliance	C_{ms}	$\mu m/N$	203.4
Resonant Frequency	f_s	Hz	589	Effective Cone Diameter	D	cm	3.2
Mechanical Q Factor	Q_{ms}	-	1.3	Effective Piston Area	S_D	cm^2	8.2
Electrical Q Factor	Q_{es}	-	0.43	Equivalent Volume	V_{as}	L	0.02
Total Q Factor	Q_{ts}	-	0.32	Motor Force Factor	BL	T·m	3.07
Ratio f_s / Q_{es}	F	f_s / Q_{es}	1826	Motor Efficiency Factor	β	$(T \cdot m^2) / \Omega$	3.16
Half Space Sensitivity @ 2.83V	$dB @ 2.83V/1m$	dB	93.6	Voice Coil Former Material	VC_{fm}	-	AL
Rated Noise Power (IEC 2685 18.1)	P	W	100	Voice Coil Inner Diameter	VC_d	mm	25.8
Test Spectrum Bandwidth	500hz - 20khz	12 dB/Oct		Maximum Linear Excursion	X_{max}	mm	0.40
				Transducer Mass	-	kg	0.783

Frequency and Impedance Response:



F088-0713A