

# **23 Step Ladder-Type Attenuator**

## **User Manual**

**Analog Metric**

[www.analogmetric.com](http://www.analogmetric.com)

[sales@analogmetric.com](mailto:sales@analogmetric.com)

Copyright© 2009 All Rights Reserved

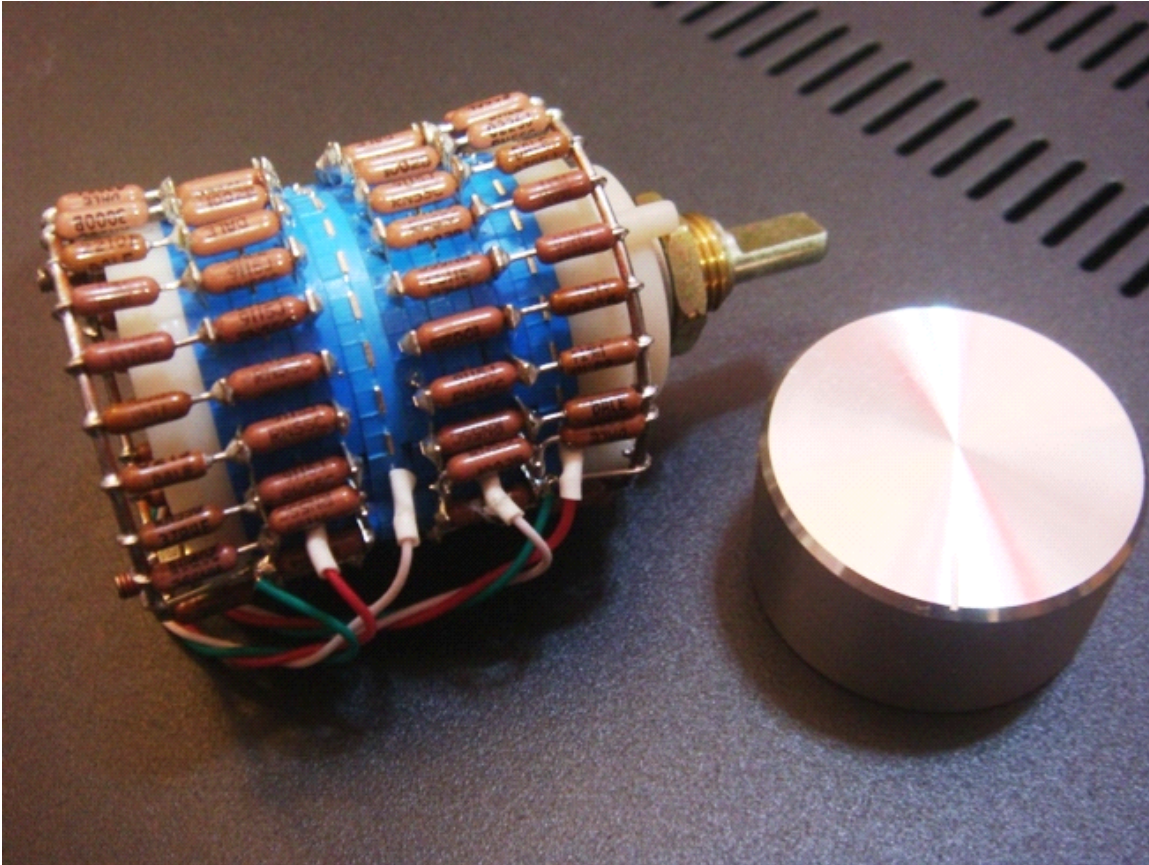

## INTRODUCTION

The most important feature of a two channel attenuator, namely potentiometer, is how well it tracks: that is, how closely matched between the two channels and also the input impedance is kept unchanged for different volume. No volume control has perfect tracking: one channel will always have a little different from the other. Even well-trained ears are only sensitive enough to notice a difference of about 1dB, though, and for the average person the minimum noticeable difference is more like 3dB. Therefore, a step attenuator is often employed in high-end audio products.

## FEATURES

- Dale resistors, 23 step attenuator and knob.
- Ladder type structure, 23 positions.
- Log scale attenuation.
- Rotary are Made-before-break
- The available values are 10k, 50k, 100k, and 250k ohm. Please contact to our sales for other customerized values.

## PROCEDURES

1. The circuit diagram is displayed as following diagram. The ladder-type resistor network consists of resistors  $R_{in}$  and  $R_g$  in serially. For one channel, there are 23 pairs of  $R_{in}$  and  $R_g$ . Therefore, there are totally 46 resistors for two channels. The total equivalent resistance of each resistor pair is  $R = R_{in} + R_g$ ; this value are kept the same, so that the input resistance is more or less the same for all position (ideally we want it to be constant)

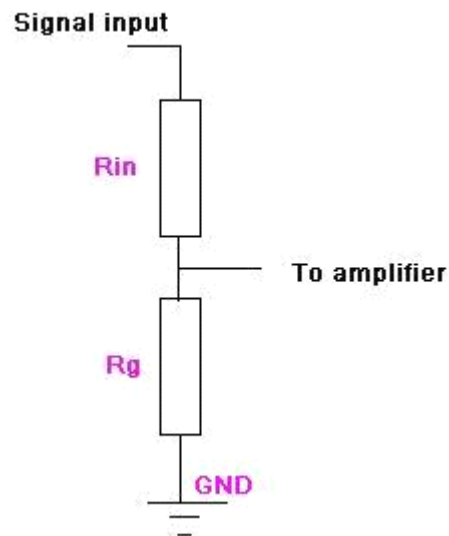

2. Identify the resistor values ( $R_{in}$  and  $R_g$ ) for two channels according to the following resistor lists (10k, 50k, 100k and 250k). You may mount the resistors by plastic tapes on a paper one by one, where the numbers of 1 to 23 are marked on the paper.

10K

Rin=10K	Rg=0
Rin=10K	Rg=10
Rin=10K	Rg=18
Rin=10K	Rg=34
Rin=10K	Rg=56
Rin=10K	Rg=100
Rin=9.76K	Rg=133
Rin=9.76K	Rg=160
Rin=9.76K	Rg=220
Rin=9.76K	Rg=300
Rin=9.53K	Rg=360
Rin=9.53K	Rg=500
Rin=9.31K	Rg=620
Rin=9.09K	Rg=820
Rin=8.8K	Rg=1.1K
Rin=8.8K	Rg=1.5K
Rin=8.2K	Rg=1.8K
Rin=7.5K	Rg=2.4K
Rin=6.8K	Rg=3.3K
Rin=5.9K	Rg=4.3K
Rin=4.7K	Rg=5.6K
Rin=3K	Rg=6.8K
Rin=0	Rg=10K

50K

Rin=50K	Rg=0
Rin=51K	Rg=51
Rin=51K	Rg=91
Rin=51K	Rg=160
Rin=51K	Rg=270
Rin=51K	Rg=500
Rin=51K	Rg=620
Rin=51K	Rg=820
Rin=47K	Rg=1.1K
Rin=47K	Rg=1.5K
Rin=47K	Rg=1.8K
Rin=47K	Rg=2.4K
Rin=47K	Rg=3.3K
Rin=47K	Rg=4.3K
Rin=43K	Rg=5.6K
Rin=43K	Rg=6.8K
Rin=39K	Rg=9.31K
Rin=39K	Rg=12K
Rin=33K	Rg=16K
Rin=30K	Rg=20K
Rin=22K	Rg=27K
Rin=15K	Rg=36K
Rin=0	Rg=50K

100K

Rin=100K	Rg=0
Rin=100K	Rg=100
Rin=100K	Rg=180
Rin=100K	Rg=316
Rin=100K	Rg=560
Rin=100K	Rg=1K
Rin=100K	Rg=1.3K
Rin=100K	Rg=1.6K
Rin=100K	Rg=2.2K
Rin=100K	Rg=3K
Rin=100K	Rg=3.6K
Rin=91K	Rg=4.7K
Rin=91K	Rg=6.2K
Rin=91K	Rg=8.2K
Rin=91K	Rg=10K
Rin=85K	Rg=15K
Rin=82K	Rg=18K
Rin=75K	Rg=24K
Rin=68K	Rg=33K
Rin=56K	Rg=43K
Rin=47K	Rg=56K
Rin=30K	Rg=72K
Rin=0	Rg=100K

250K

Rin=250K	Rg=0
Rin=250K	Rg=249
Rin=250K	Rg=430
Rin=250K	Rg=780
Rin=250K	Rg=1.3K
Rin=250K	Rg=2.4K
Rin=250K	Rg=3.3K
Rin=250K	Rg=4.3K
Rin=240K	Rg=5.6K
Rin=240K	Rg=6.8K
Rin=240K	Rg=9.31K
Rin=240K	Rg=12K
Rin=240K	Rg=16K
Rin=220K	Rg=20K
Rin=220K	Rg=27K
Rin=220K	Rg=36K
Rin=200K	Rg=47K
Rin=180K	Rg=62K
Rin=170K	Rg=82K
Rin=150K	Rg=100K
Rin=120K	Rg=130K
Rin=72K	Rg=180K
Rin=0	Rg=250K

3. Locate the position 1, 2, 3, ..., 23 for both channel 1 and channel 2.

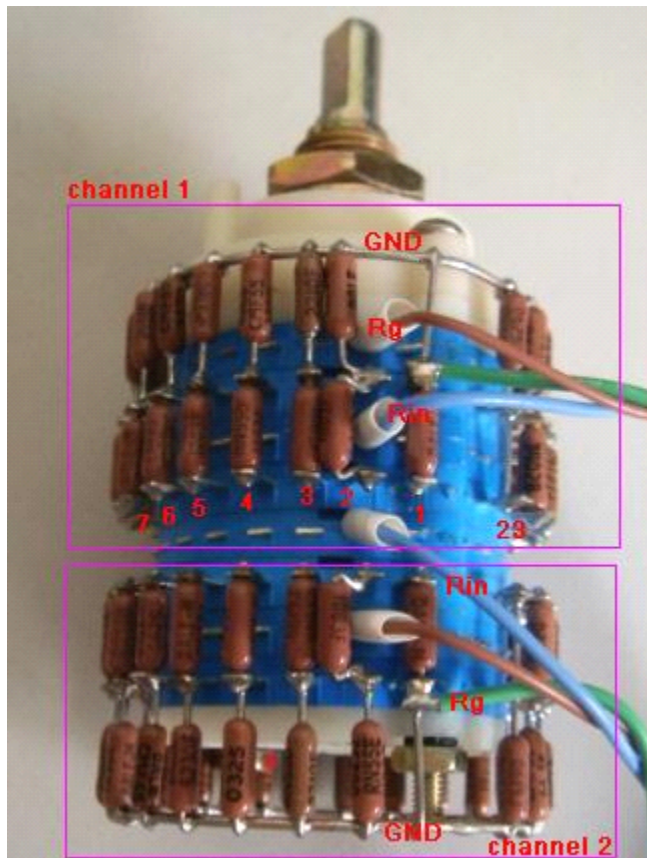

4. Make two wires without shields for ground wires. Solder the resistor pair  $R_{in}$  and  $R_g$  for both channels.
5. Connect the wires for GND, signal in, and signal out. Here the blue, brown, and green are for the  $R_{in}$ ,  $R_g$ , and GND, respectively.

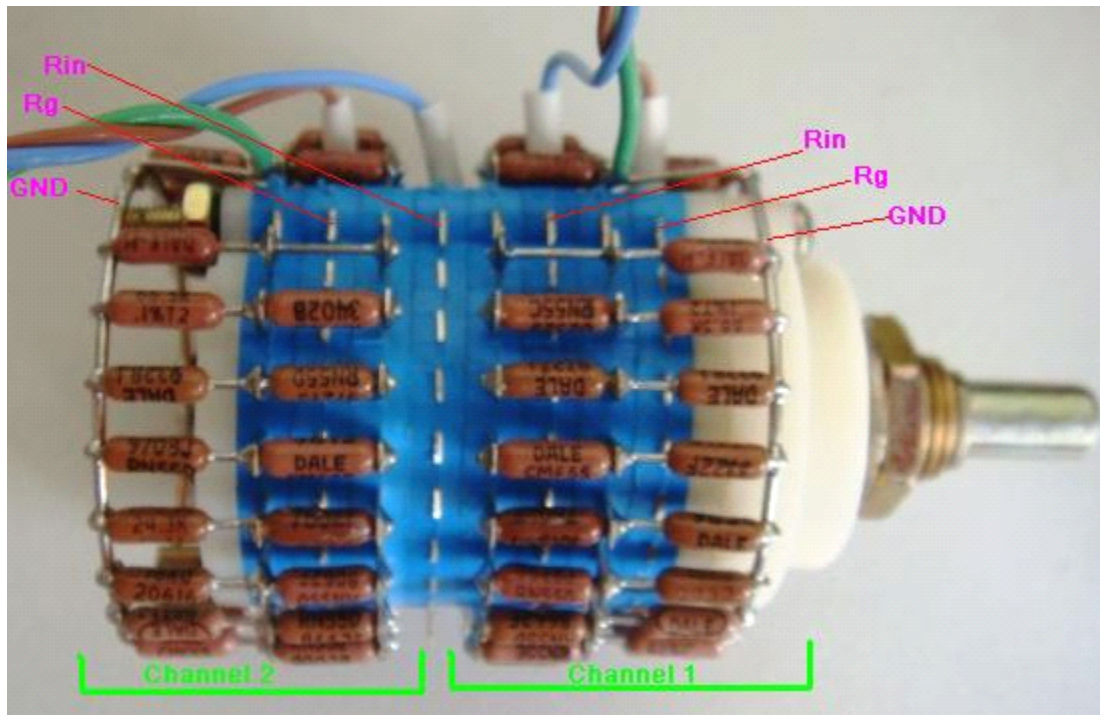
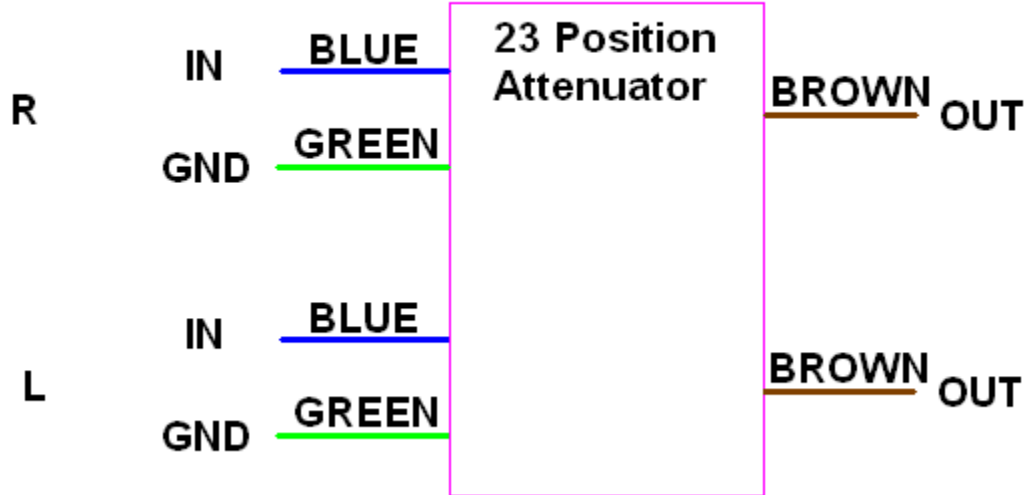

6. Finally, the complete one should be look like:

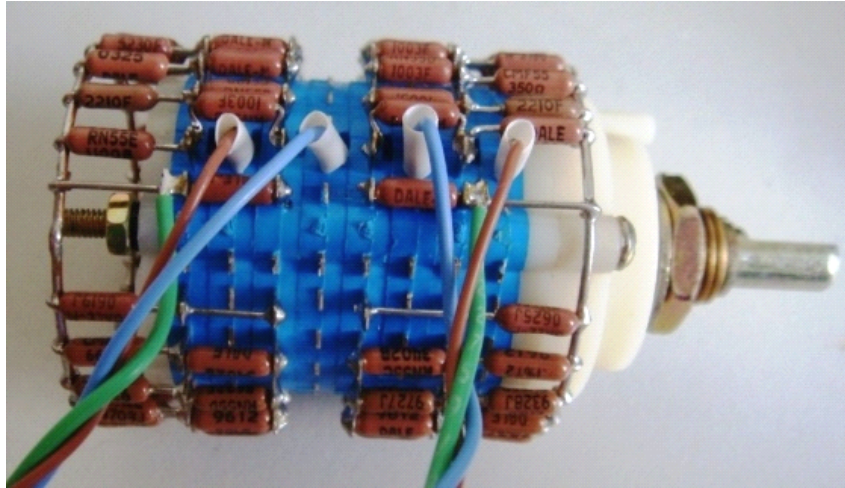

7. Enjoy it.

If you have any problem in assembly, please contact us by email to [tech@analogmetric.com](mailto:tech@analogmetric.com)