

Delay Protection

User Manual

Analog Metric

www.analogmetric.com

sales@analogmetric.com

Copyright© 2009 All Rights Reserved

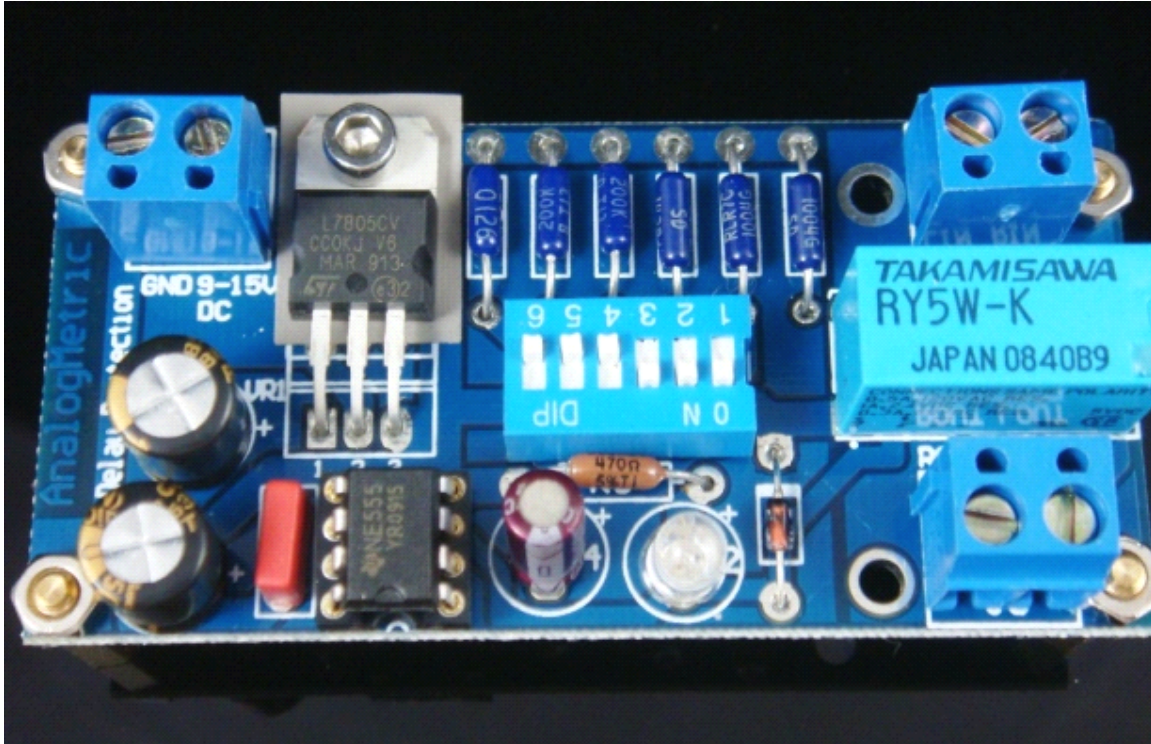

FEATURES

- Timing Adjustable relay switches from milli-seconds to hours.
- Time setting by varies RC value of the 555 Timer.
- Built-in low dropout voltage regulator LM1086-5 IC.
- Wide range of DC Power supply: 6-30V
- Maximum rating of Relay: 120VAC 1A
- Applications: Delay protection for speaker, power supply, etc.
- PCB dimension: 76.8mm (W) x 37.3mm (L)
- PCB thickness: 2.5mm, double layer, 2oz copper.

PROCEDURES

1. Solder the components according to the schematic and BOM.
2. The timing constant (delay time) is set by the RC time constant, that are the resistors R1, R2, R3, R4, R5, and R6, and C4. The higher the time constant, the longer delay time will be resulted. The relationship between the delay time ranged from micro seconds to few seconds is shown in the below figure.

By properly setting the RC value, you can control the delay time of the relay

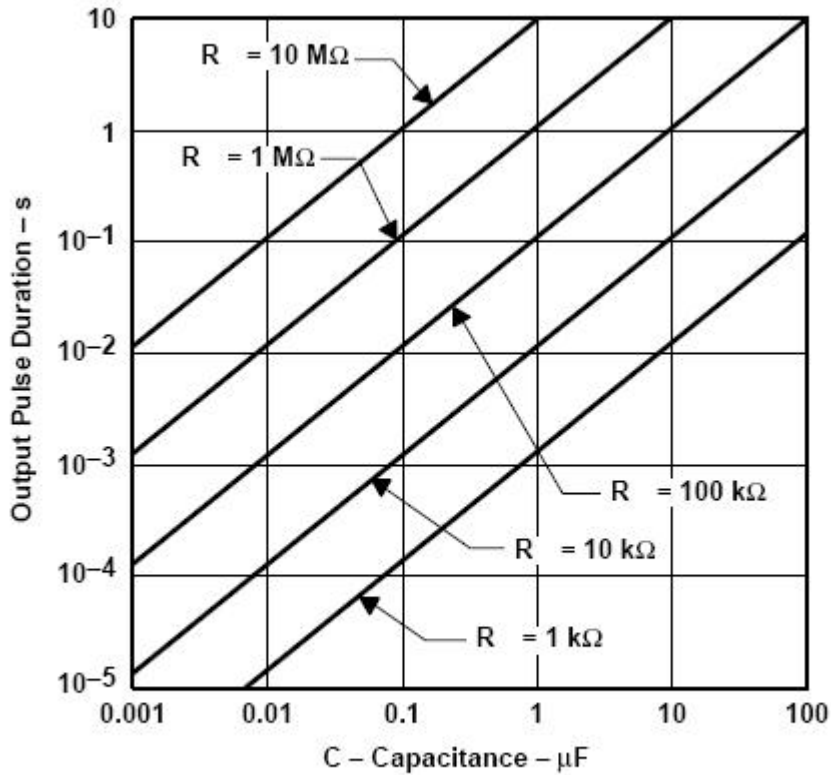

$$T=1.1RC$$

switch.

3. Apply the power supply, you will hear the 'click' sound or LED light up when the relay are switched on after the predefined delay timing.

If you have any problems in assembly, please contact us by email tech@analogmetric.com

AnalogMetric Delay Protection (2 Channels)

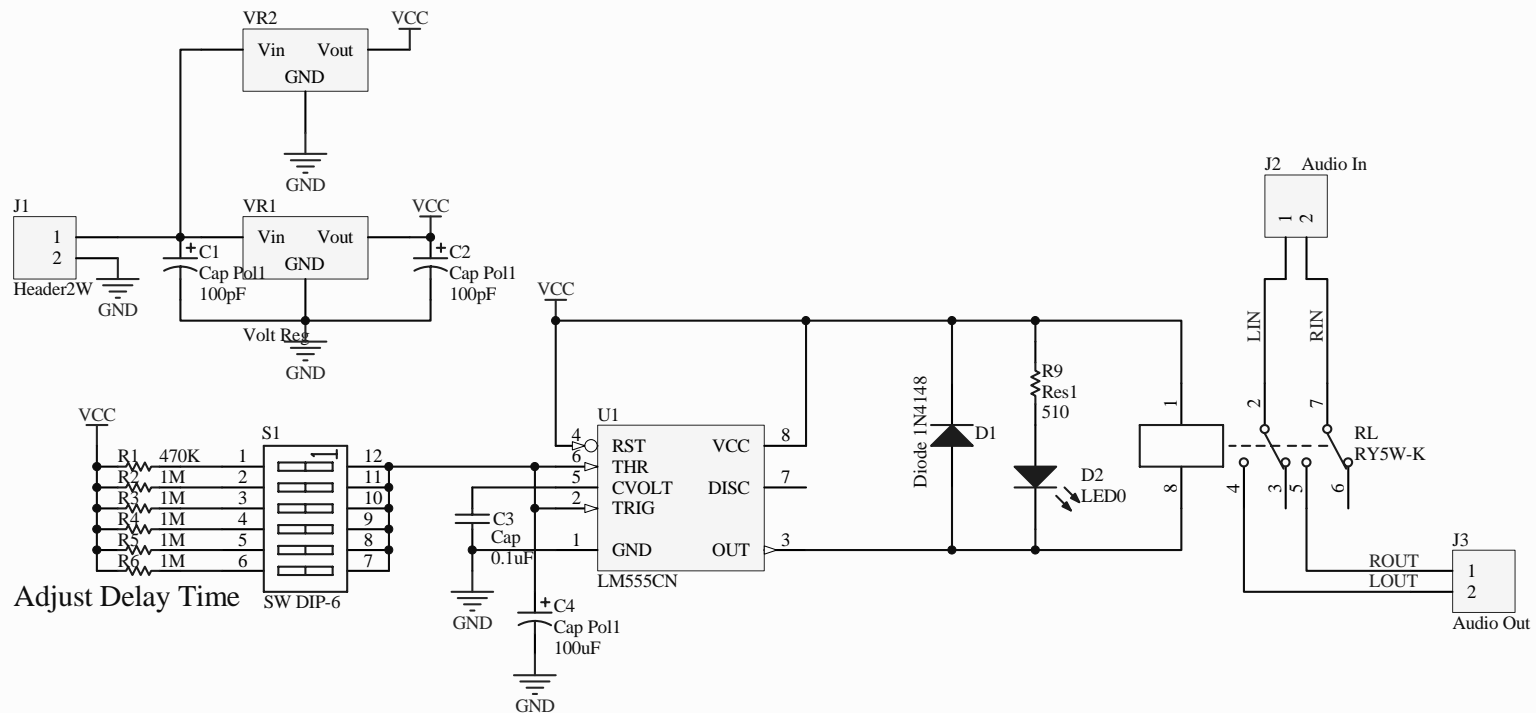

<http://www.AnalogMetric.com>

Title		
Size	Number	Revision
A		
Date:	11/5/2008	Sheet of
File:	C:\DOCUMENTS AND SETTINGS\...Delay Protection.SchDoc	1 of 1

Analog Metric

Delay Protection (2 Channels)

Components	Values	Quantity	Remarks
C1, C2	100uF/50V	2	Electrolytic Capacitor
C3	0.1uF/100V	1	Thin Film Capacitor
C4	100uF/16V	1	Electrolytic Capacitor
D1	1N4148	1	
D2	3mm Blue LED	1	
R1, R2, R3,R4	1M 1/4W	3	Delay time depend on these resistor values
R5, R6	470K 1/4W	2	Delay time depend on these resistor values
R9	470R 1/4W	1	
RY1	RY5W-K	1	5V Relay
VR1	7805	1	Voltage regulator
VR2	LM1086-5	1	optional
U2	LM555	1	
J1, J2, J3	2PIN Connector	3	
SW1	6 DIP Switch	1	
S1	8 DIP IC Socket	1	
TSOP epox		1	
3mm screw and copper rod		4	
PCB		1	