



**2*100 watt @ 4ohm TK2050 Class-D
Audio Amplifier Board
User's Guide**

Table of Contents

Chapter1.Overview	1
1.1 Welcome	1
1.2 Quick Start	3
Chapter2.Hardware Detail	5
2.1 Power Connection	5
2.2 Input Connections	5
2.3 Output Connections	5
2.4 Connection with Next Board	6
2.5 Mute Setting	6
2.6 Gain Settings	6
2.7 DC Offset	6
2.8 LED Indicators	7
2.9 Volume Control	7
Chapter3.Electrical Characteristics	8
Chapter4.Mechanical Drawing	9
Chapter5.Appendix	10
Schematics	10
Chapter6.Contact Us	12

2*100 watt @4ohm TK2050 Class-D Audio Amplifier Board

NOTES:

Product Version : Ver 1.0

Document Version : Ver 1.2

Chapter1.Overview

1.1 Welcome

This self-made 2*100W audio amplifier board is a perfect class-D architecture integrated with Tripath TC2000 and TP2050. It supports dual channel amplification and can readily be powered by any DC power supply ranging from +10 to 36V. You can use it to drive any 4Ω or 8Ω passive speakers.

As quoted from the datasheet of Tripath, TC2000 is a two-channel audio controller that uses Tripath's proprietary Digital Power Processing (DPP™) technology. When combined with switching power output stages, the TC2000 allows the implementation of a complete Class-T audio amplifier. TP2050 is a stereo power stage capable of 50W continuous average power per channel, Class-T Digital Audio Power Amplifier using Tripath's proprietary Digital Power Processing™ technology. The TP2050 can be coupled with a Class-T controller such as TC2000 or TC2001 to produce a high-quality stereo amplifier.

To put it simple, TC2000 converts analogue audio signal it receives into digital signal and TP2050 amplifies the digital signal from TC2000. This amplifier board integrates two TP2050 chips to support dual channel amplification of up to 100W each. The absolute maximum voltage of TP2050 chip is rated at 40V, so 36V is the very maximum recommended rail voltage. The maximum voltage of TC2000 shall not exceed 5V.

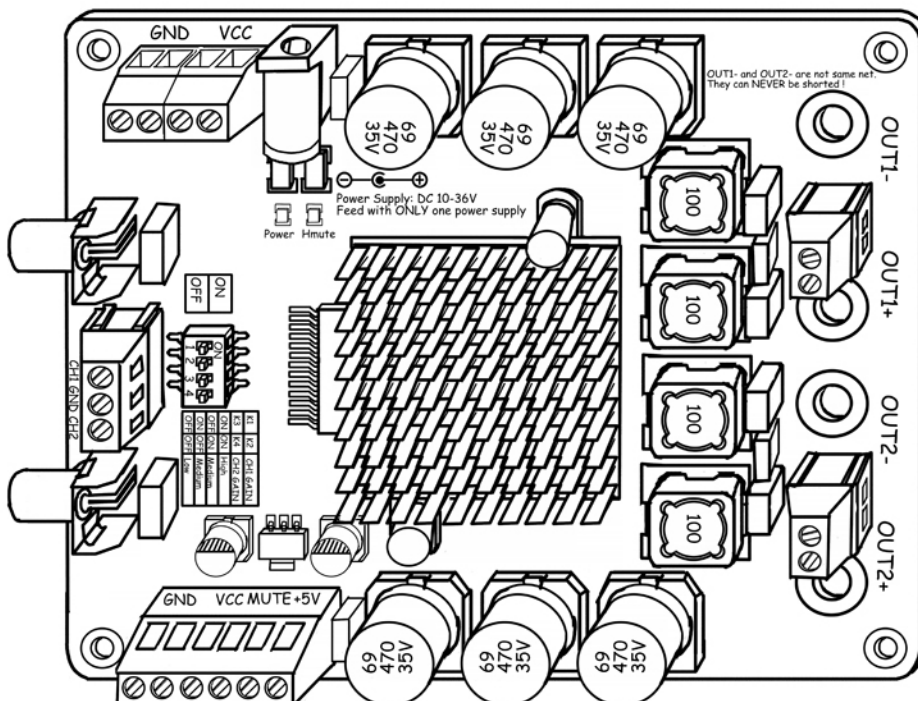

Figure 1 Product Diagram

Notice: The diagram above is used for reference only.

Overview

Features:

- Fully bridged stereo output, the output of this product cannot be bridged again.
- Maximum voltage of power supply is 36V
- Line level analogue audio input
- Sensitivity and gain are adjustable with on-board DIP switch
- +5V screw terminal for mute
- Over / under voltage turn off
- Over current protection
- Over temperature protection

Applications

- Powered Subwoofers
- Home Theater Receivers
- Multi-channel Distribution
- Powered DVD Systems
- Mini/Micro Systems

Benefits

- Mounting holes are available for easy installation and fix
- Several wiring methods facilitate connection
- The design of power supply allows you to connect more amplifier boards.
- Excellent heat sink eliminates your worry over heat dissipation.

1.2 Quick Start

Suggested connection is shown in Figure 2.

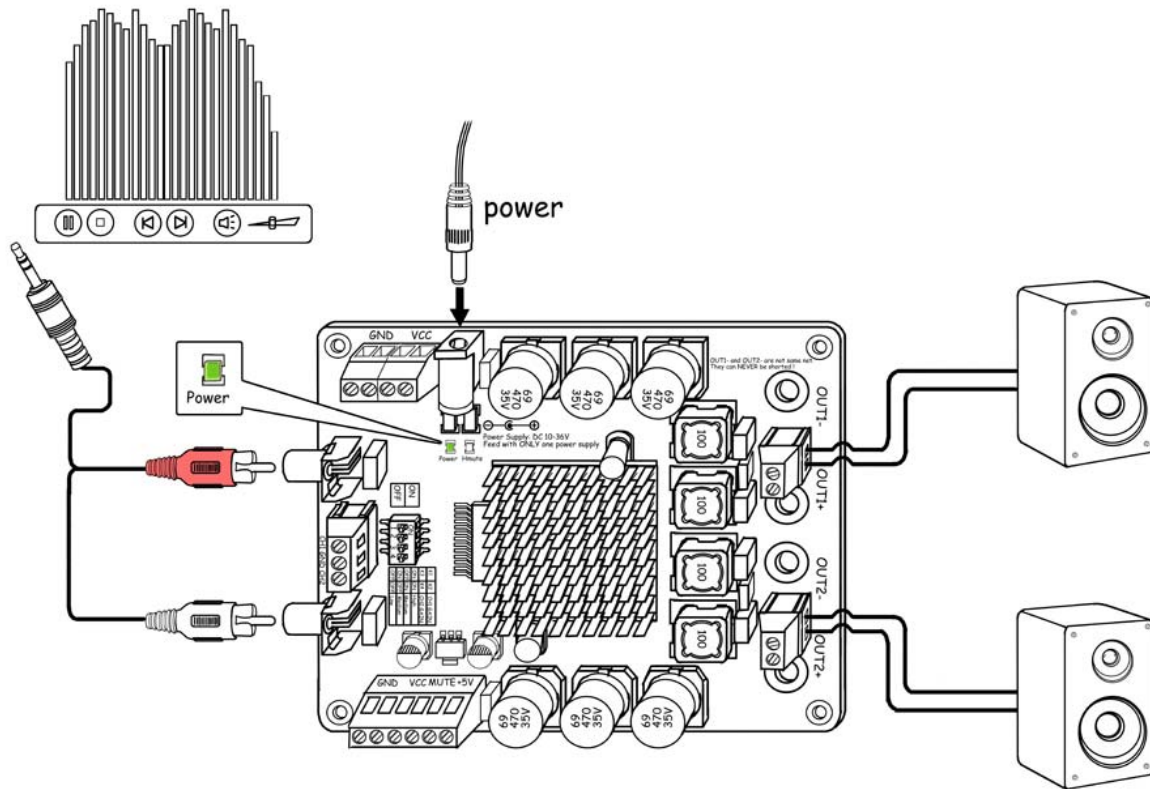

Figure 2 Connection Schematic

Notice:

Please observe the following steps to complete verification so as to ensure the products are intact during transit.

1. Open the amplifier package and make sure the product is intact (No missing or damaged components and no deformation)
2. Please observe the connection diagram when connecting the amplifier board. Use a nearby sound source, such as MP3 or CD player to have a trial. This amplifier board can be deemed as qualified if you can hear the sound correspond to that sound source.

Overview

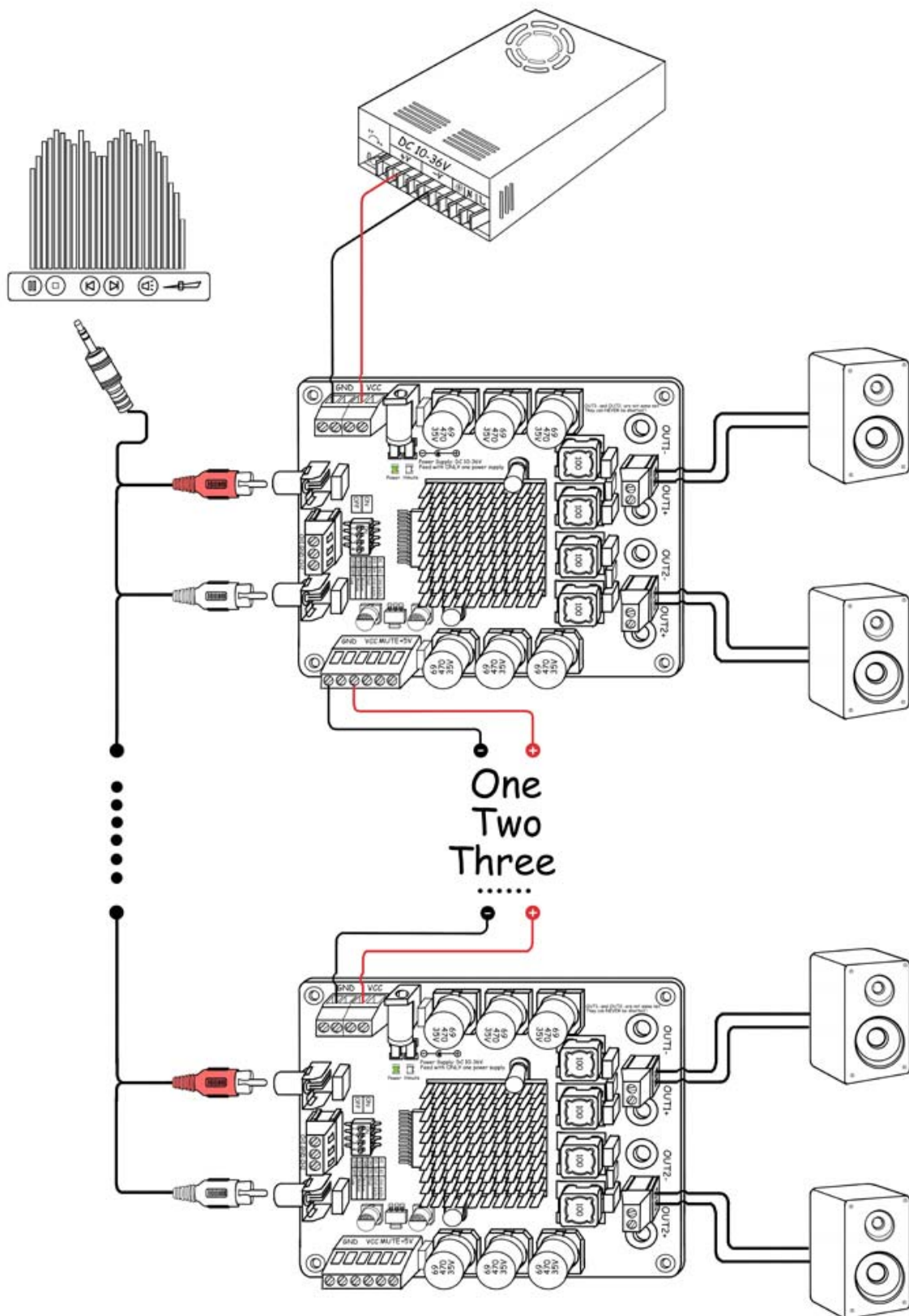

Figure 3 Cascade Schematic

Notes:

1. GND should be connected to ground or the housing of your instrument.
2. Never connect "OUT1-" and "OUT2-" since they are not in the same net.

Chapter 2. Hardware Detail

2.1 Power Connection

To power the amplifier board, use either jack or terminal blocks. On-board diodes can prevent the consequence of wrong connection of power supply.

Connector Mark		Description	
Jack	J3	DC 10-36V Power Supply	
Terminal Blocks	J1	VCC	Positive (+) of DC 10-36V Power Supply
	J5	GND	Negative (GND) of DC 10-36V Power Supply

Warning:

You are allowed to use only one way for powering the amplifier board at a time. The maximum voltage of power supply shall not exceed 36V.

2.2 Input Connections

You may use either RCA connectors or terminal blocks to input audio signal.

Connector Mark		Channel
RCA Connectors	J7	Channel 1 Input
	J9	Channel 2 Input
Terminal Blocks	J8(PIN1)	Channel 1 Input
	J8(PIN3)	Channel 2 Input

Warning:

You are allowed to feed only one group (dual channel) of audio signal to the amplifier board at a time. Please refer to 2.6 "Gain Setting" for details.

2.3 Output Connections

You can use either terminal blocks or banana connectors to output audio signal. Two pairs of banana connectors are provided for free.

Connector Mark		Description
Banana Connectors	J10	Positive output of Channel 1
	J12	Negative output of Channel 1
	J15	Positive output of Channel 2
	J13	Negative output of Channel 2
Terminal Blocks Refer to on-board descriptions for connection details	J11	Output of Channel 1
	J14	Output of Channel 2

Warning:

Never connect more than one group of speaker to the audio output.

Hardware Detail

2.4 Connection with Next board

J4 and J2 on terminal block are used to connect more amplifier board.

Connector Mark		Description
J4	VDD	Positive (+) of DC 10-36V Power Supply to next board
J2	GND	Negative (GND) of DC 10-36V Power Supply to next board

Notice:

It is allowed to connect more amplifier boards in series, but it would be better to limit that number to 4. Remember to use AWG12-compliant cable or equivalent for series connection.

2.5 Mute Setting

To mute the output audio signal, connect "+5V" and "MUTE" of the terminal block with a piece of lead. In normal use, "MUTE" shall be left unconnected.

Connector Mark		Description
J6	MUTE	When "MUTE" is connected with "+5V", both amplifiers will be muted and enter into idle mode. When connected to ground or left disconnected, both amplifiers will resume to regular operation.

Notice:

When you select power supply for the board, the appropriate voltage is DC 10-36V. Never connect "MUTE" on the terminal block to any power supply or any other voltage higher than 5V.

2.6 Gain Settings

The on-board 4-slide DIP switch, which is marked as "SW1", is used to set the gain of amplifier board. 4 slides are marked as K1, K2, K3 and K4 respectively. K1 and K2 are used to set the gain of channel 1 while K3 and K4 are used for channel 2. The following table lists the gain values on different settings:

Channel 1 Setting		Channel 2 Setting		Amplifier Gain		
K1	K2	K3	K4	Gain Level	Power Gain (dB) Typical	Voltage Gain (V/V) Typical
ON	ON	ON	ON	High	24	16
OFF	ON	OFF	ON	Medium	30	32
ON	OFF	ON	OFF	Medium	30	32
OFF	OFF	OFF	OFF	Low	34	48

Tips:

High: Portable MP3/CD player with built-in volume control.

Medium: General-purpose use

Low: Preamplifier with fairly high output signal

2.7 DC Offset

If it is not quite necessary, DO NOT trim the output offset by adjusting "R5" and "R26"-two

potentiometers on board since we have already regulated that offset to a range of +/- 10mV. You may refer to the connection diagram for the location of potentiometers.

Warning:

Adjusting these potentiometers may damage your speakers.

2.8 LED Indicators

This amplifier board has two indicators, one of which is marked as “Power (D3)”; another is “Hmute (D4)”. The power indicator will be illuminated in green on power-up and “Hmute” will be illuminated in blue when you mute the amplifier audio output or amplifier board error occurs. Please refer to the TK2050 Data Sheet for a complete description of HMUTE. Please refer to the Board Connection Diagram for the LED locations on amplifier board.

2.9 Volume Control

This amplifier board doesn't include any potentiometer which could be used to manually adjust the volume control. Users may use the volume control of the sound source (such as MP3 player or PC) to adjust the loudness of the audio output. If you need a potentiometer, you may install one (50Kohm) by yourself, but it may void the warranty at the same time. Another reason for not installing potentiometer is the signal attenuation it may occur after installation. To compensate that attenuation, adjusting the gain value is required. You may refer to 2.6 Gain setting for details.

Please be aware that audio clippings (waveform distortion) may occur for some portable players, these are the clippings generated by the audio source, not the amplifier itself; please increase the input gain of amplifier board.

Chapter3.Electrical Characteristics

The following table lists all typical data. For full specifications, please refer to the Tripath data sheet of TK2050 chip.

	Min	Typical	Max
Supply voltage	10V	24V	36V
Over-current shutdown	7A	12A	16A
Signal/Noise Ratio		80dBA	
THD+N		Not tested	
Channel separation		95dB	
Efficiency		85%-90%	
Output power 4 ohm* @30V rail		75W<0.01THD+N, 115W 10% THD+N	
Output power 8 ohm* @30V rail		35W<0.01THD+N, 60W 10% THD+N	
Offset voltage		Adjustable below 100mV	
Output noise		135mV	
Input impedance		Nominally 22 to 47 K	
Power stage gain		Set by dip switch	
Thermal warning*		130°C	
Thermal shutdown*		150°C	

Notice: *The chip specifications by Tripath.

Chapter4.Mechanical Drawing

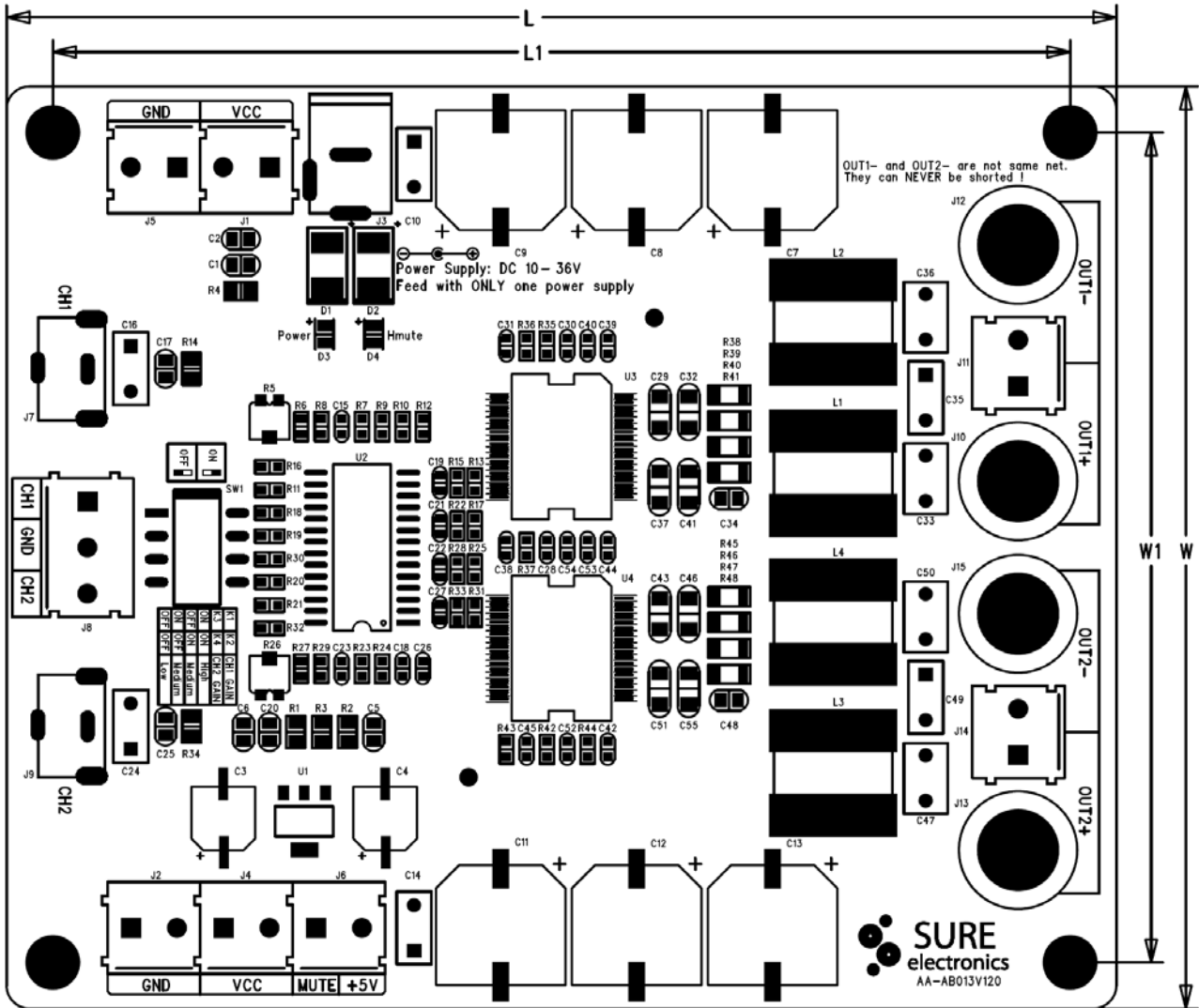
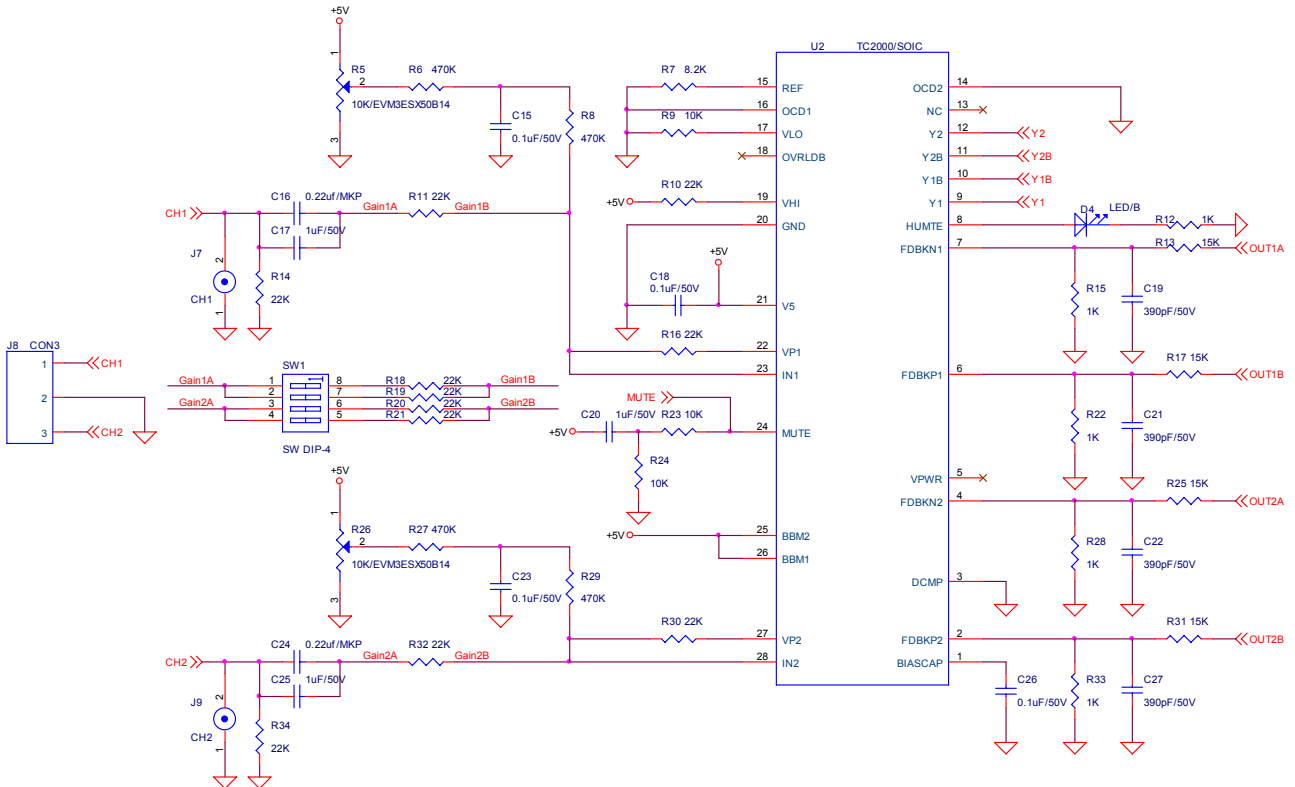
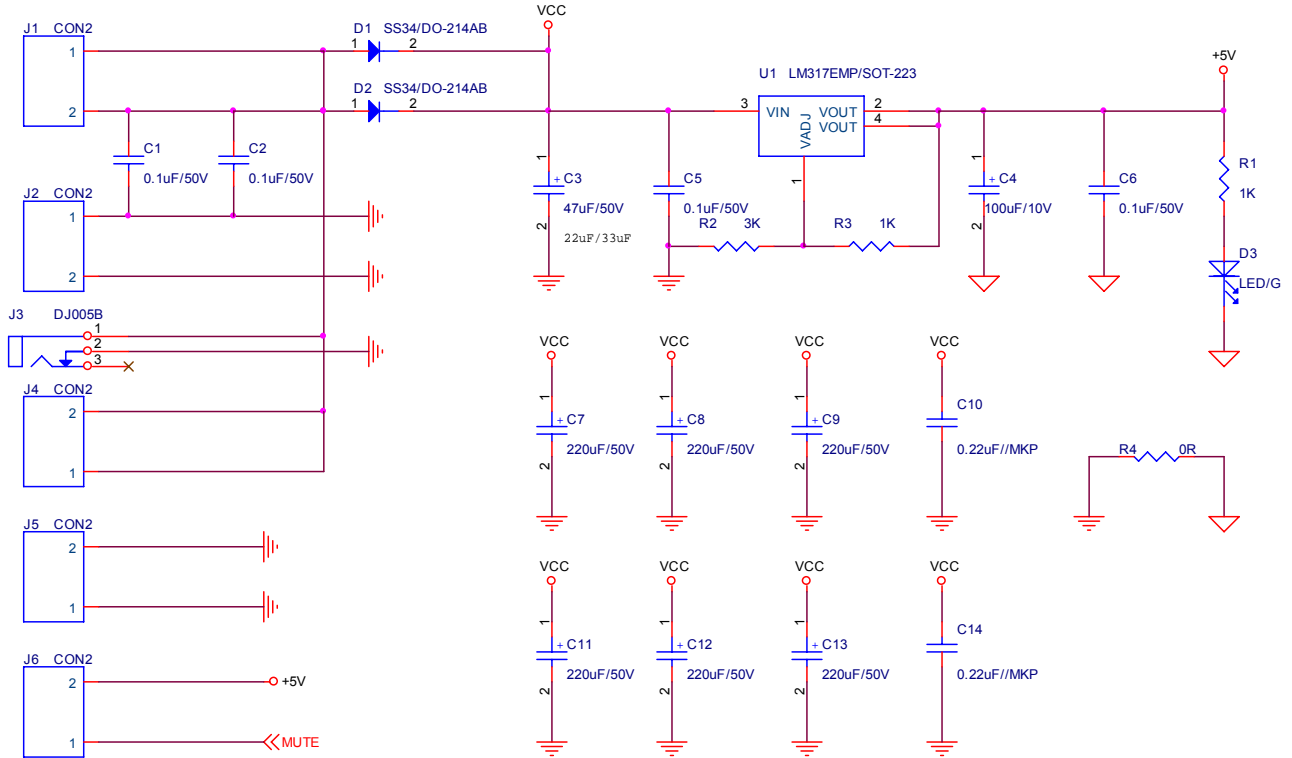

Figure 4

Symbol	L	L1	W	W1
Inch	4.80	4.40	4.00	3.60
mm	121.92	111.76	101.60	91.44

Chapter5.Appendix

Schematics



Appendix

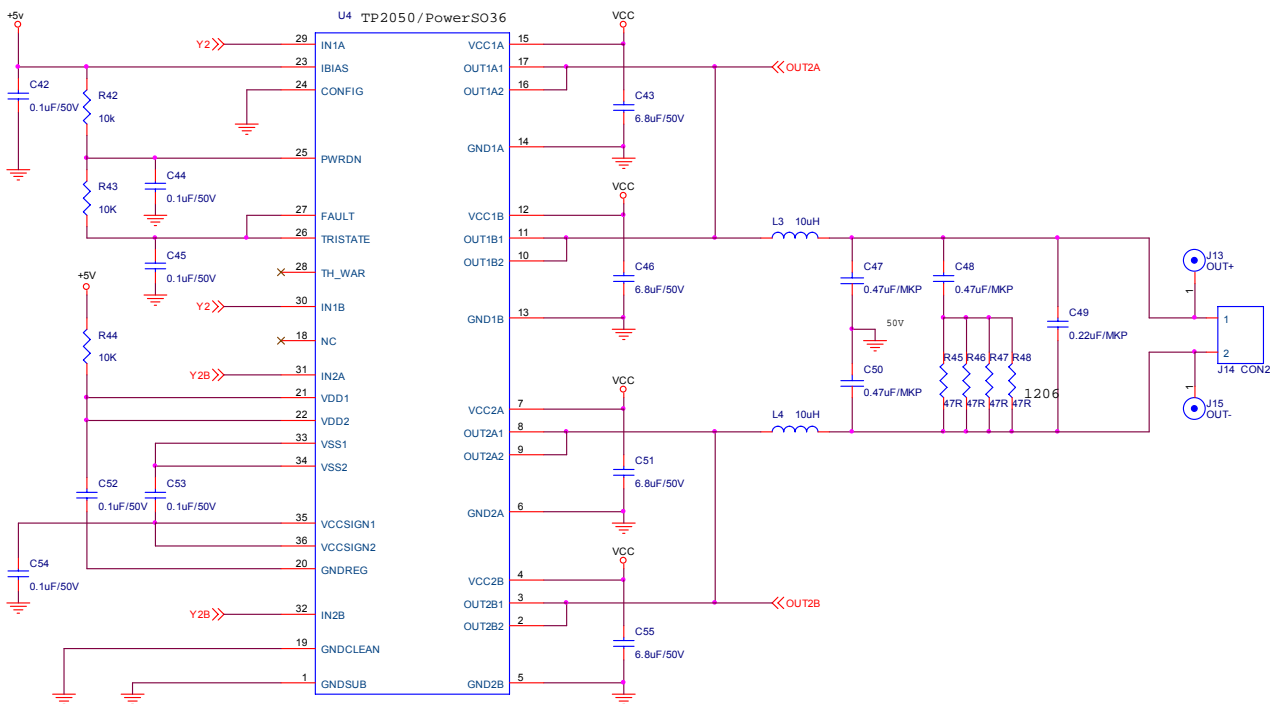
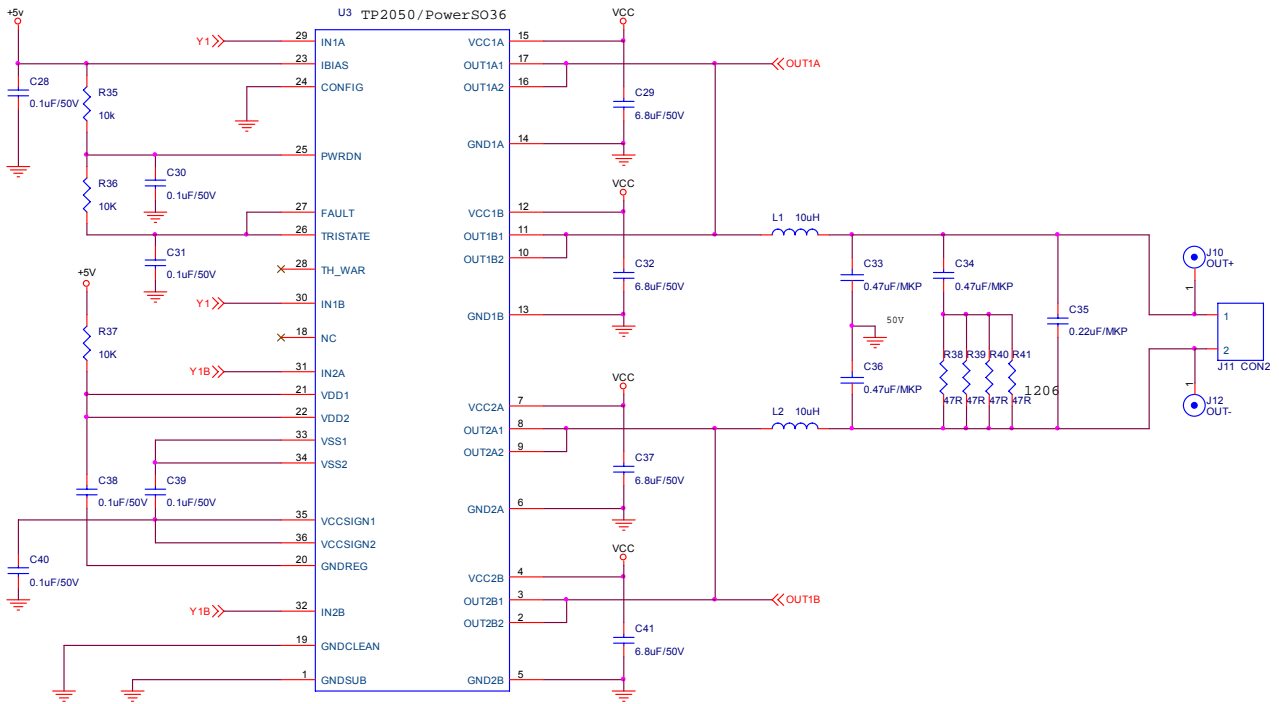

Figure 5 Schematics

Notice: The above schematics are used for reference only. There might be a tiny difference in production batch.

Chapter6.Contact Us

Sure Electronics Co., Ltd.

5F, Zone A,
Qinhuai Technology Innovation Center
105-2 DaMing Rd (ZIP:210022)
Nanjing
P.R.China

Tel: +86-13601408832 (For technical questions only)
+86-25-66606340 (English service, from GMT1-10AM)
Fax: +86-25- 66606341-866
Website: www.sure-electronics.com
www.sure-electronics.net