



For more Hi-Fi manuals and set-up information
please visit www.hifiengine.com

Service Manual

Amplifier

SE-CA10

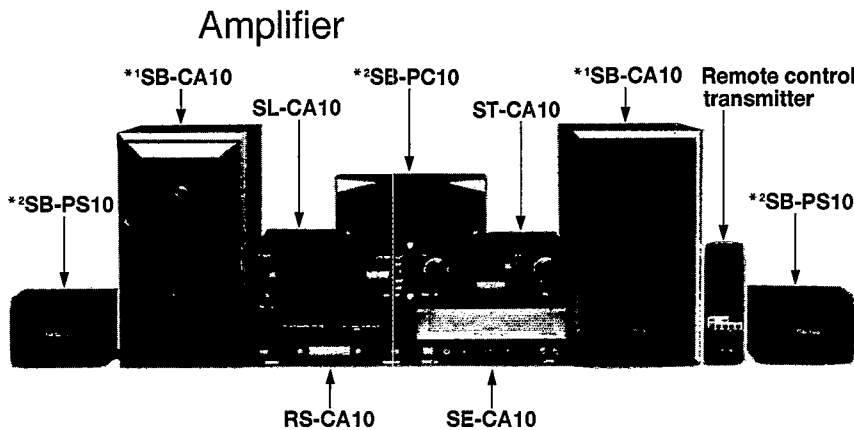

Colour

(K)...Black Type

Area

Suffix for Model No.	Area	Colour
(E)	Europe.	(K)
(EB)	Great Britain.	
(EG)	Germany and Italy.	
(GC)	Asia, Latin America, Middle Near east and Africa.	
(GN)	Oceania.	

Because of unique interconnecting cables, when a component requires service, send or bring in the entire system.

System: SC-CA10

SPECIFICATIONS

Amplifier section

Power output

DIN 1 kHz, THD 1%, both channel driven	2×50 W (6Ω)
RMS 1 kHz, THD 10%, both channel driven	
[For (E, EB, EG, GN) areas]	2×70 W (6Ω)
[For (GC) area]	2×65W (6Ω)

PRO LOGIC mode

DIN 1 kHz, THD 1%	
MAIN (both channels driven)	2×40 W (6Ω)
SURROUND	40 W (4Ω+4Ω)
CENTER	40 W (8Ω)
RMS 1 kHz, THD 10%	
MAIN (both channels driven)	2×50 W (6Ω)
SURROUND	50 W (4Ω+4Ω)
CENTER	50 W (8Ω)

Total harmonic distortion

Rated power at 1 kHz	1% (6Ω)
Half power at 1 kHz	0.09% (6Ω)
Load impedance	
MAIN	6Ω – 8Ω

SURROUND

4Ω – 8Ω

CENTER

8Ω

S/N (rated power)

90 dB

MAIN

General

Power consumption

235 W

Power supply

[For (E, EG) areas]	230 V, AC 50/60 Hz
[For (EB, GN) areas]	230 – 240 V, AC 50/60 Hz
[For (GC) area]	110/127/220/230 – 240 V, AC 50/60 Hz

Dimensions (W×H×D)

270×118.5×341.5 mm

Weight

5.2 kg

Note:

Specifications are subject to change without notice.
Weight and dimensions are approximate.
Total harmonic distortion is measured by the digital spectrum analyzer.

System	Tuner	CD changer	Amplifier	Cassette deck	Speakers
SC-CA10	ST-CA10	SL-CA10	SE-CA10	RS-CA10	*1 SB-CA10 *2 SB-PT10 (SB-PC10+SB-PS10)

* 1 Made in PAES
* 2 For (E, EB, EG) areas....Made in PAES
For (GC, GN) areas....Made in NABEL

⚠ WARNING

This service information is designed for experienced repair technicians only and is not designed for use by the general public. It does not contain warnings or cautions to advise non-technical individuals of potential dangers in attempting to service a product. Products powered by electricity should be serviced or repaired only by experienced professional technicians. Any attempt to service or repair the product or products dealt with in this service information by anyone else could result in serious injury or death.

Technics®

© 1995 Matsushita Electric Industrial Co., Ltd.
All rights reserved. Unauthorized copying and distribution is a violation of law.

CONTENTS

	Page		Page
ACCESSORIES	2	REPLACEMENT OF THE FOOT	16
BEFORE REPAIR AND ADJUSTMENT	2	POWER SOURCE ON/OFF OF THIS UNIT	16
PROTECTION CIRCUITRY	3	MEASUREMENTS AND ADJUSTMENTS	16
CAUTION FOR AC MAIN LEAD	3	SCHEMATIC DIAGRAM	17~21
LOCATION OF CONTROLS	4	PRINTED CIRCUIT BOARD DIAGRAM	22~25
INSTALLATION	4	WIRING CONNECTION DIAGRAM	25
CONNECTIONS	5~9	BLOCK DIAGRAM	26, 27
USING THE DOLBY PRO LOGIC SURROUND	10	CABINET PARTS LOCATION	28
ADJUSTING SPEAKER OUTPUT LEVEL	11	REPLACEMENT PARTS LIST	29, 30, 32, 33
ADJUSTING THE DELAY TIME	12	RESISTORS AND CAPACITORS	31, 32
ENJOYING WITH SURROUND OR 3 STEREO	12	PACKAGING	33
OPERATION CHECK AND MAIN COMPONENT REPLACEMENT PROCEDURES	13~15		

ACCESSORIES

- AC power supply cord
 - For (E, EG, GC) areas: (RJA0019-2K)..... 1
 - For (EB) area: (RJA0049-K)..... 1
 - For (GN) area: (RJA0036-K)..... 1
- Flat cable
 - Long (REX0661) 1
 - Middle (REX0660)..... 1
 - Short (REX0608)..... 1
- Mounting screw (STN3+12AFZ)..... 1
- Antenna holder (RMN0244)..... 1
- AM (LW/MW) loop antenna (RSA0012) 1
- Speaker cords (REE0393) 2
- Remote control transmitter
 - For (E, EG) areas: (RAK-CH744WH)..... 1
 - For (EB, GC, GN) areas:
(RAK-CH745WH) 1
- FM indoor antenna
 - For (E, EB, EG) areas: (RSA0007) 1
 - For (GC, GN) areas: (RSA0006)..... 1
- Power plug adapter
 - For (GC) area only: (SJP5213-1)..... 1
- Batteries (UM-4, "AAA", R03)..... 2
Note: These are available on sales route.
- Attachment plug
 - For (EB) area only: (SJP9009)..... 1

BEFORE REPAIR AND ADJUSTMENT

- (1) Turn off the power supply using a 10Ω, 10 W resistor, connect both ends of power supply capacitors (C701, C702) in order to discharge the voltage.
- (2) Before turning the power supply on, after completion of repair, slowly apply the primary voltage by using a power supply voltage controller to make sure that the consumed current at 50/60 Hz in NO SIGNAL mode should be shown below with respect to supply voltage 230 V/240 V/110 V.

Area	(E) (EG)		(EB) (GN)		(GC)		
	AC 230 V		AC 240 V		AC 110 V		AC 240 V
Consumed current 50/60 Hz	50 Hz	80~230 mA	50 Hz	80~230 mA	50 Hz	200~500 mA	100~250 mA
	60 Hz	64~184 mA	60 Hz	64~184 mA	60 Hz	160~400 mA	80~200 mA

■ PROTECTION CIRCUITRY

The protection circuitry may have operated if either of the following conditions is noticed:

- * No sound is heard when the power is switched ON.
- * Sound stops during a performance.

The function of this circuitry is prevent circuitry damage if, for example, the positive and negative speaker connection wires are "shorted", or if speaker systems with an impedance less than the indicated rated impedance of this unit are used.

If this occurs, follow the procedure outlined below:

1. Switch OFF the power.
2. Determine the cause of the problem and correct it.
3. Switch ON the power once again.

Note:

When the protection circuitry functions, the unit will not operate unless the power is first switched OFF and then ON again.

■ CAUTION FOR AC MAIN LEAD



[(EB) area code mode only]

For your safety, please read the following text carefully.

This appliance is supplied with a moulded three pin mains plug for your safety and convenience.

A 5-ampere fuse is fitted in this plug.

Should the fuse need to be replaced please ensure that the replacement fuse has a rating of 5-ampere and that it is approved by ASTA or BSI to BS1362.

Check for the ASTA mark  or the BSI mark  on the body of the fuse.

If the plug contains a removable fuse cover you must ensure that it is refitted when the fuse is replaced.

If you lose the fuse cover the plug must not be used until a replacement cover is obtained.

A replacement fuse cover can be purchased from your local

CAUTION!

IF THE FITTED MOULDED PLUG IS UNSUITABLE FOR THE SOCKET OUTLET IN YOUR HOME THEN THE FUSE SHOULD BE REMOVED AND THE PLUG CUT OFF AND DISPOSED OF SAFELY.

THERE IS A DANGER OF SEVERE ELECTRICAL SHOCK IF THE CUT OFF PLUG IS INSERTED INTO ANY 13-AMPERE SOCKET.

If a new plug is to be fitted please observe the wiring code as shown below.

If in any doubt please consult a qualified electrician.

IMPORTANT

The wire in this mains lead are coloured in accordance with the following code:

- Blue: Neutral
- Brown: Live

As the colours of the wires in the mains lead of this appliance may not correspond with the coloured markings identifying the terminals in your plug, proceed as follows:

The wire which is coloured BLUE must be connected to the terminal in the plug which is marked with the letter N or coloured BLACK.

This apparatus was produced to BS 800.

The wire which is coloured BROWN must be connected to the terminal in the plug which is marked with the letter L or coloured RED.

Under no circumstances should either of these wires be connected to the earth terminal of the three pin plug, marked with the letter E or the Earth Symbol .

Before use

Remove the connector cover as follows.

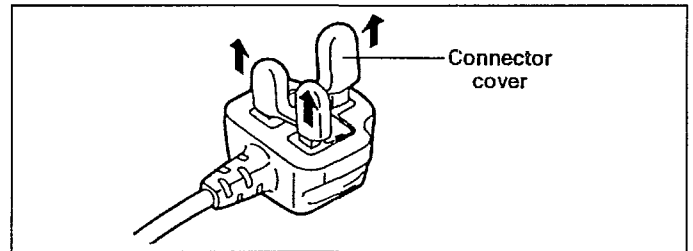

How to replace the fuse

1. Remove the fuse cover with a screwdriver.

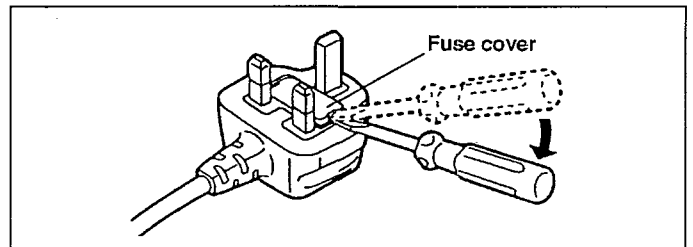

2. Replace the fuse and attach the fuse cover.

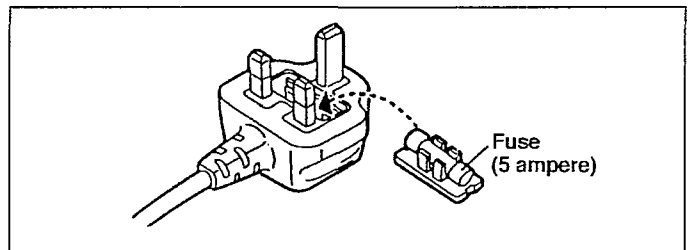

LOCATION OF CONTROLS

- ① **Output power meter**
Indicates the output (watts) of this unit.
- ② **Power "STANDBY ⏻/ON" switch**
(POWER, STANDBY ⏻/ON)
Press to switch the unit from on to standby mode or vice versa. In standby mode, the unit is still consuming a small amount of power.
- ③ **Standby indicator (STANDBY)**
When the unit is connected to the AC mains supply, this indicator lights up in standby mode and goes out when the unit is turned on.
- ④ **Headphones jack (PHONES)**
- ⑤ **DOLBY PRO LOGIC mode select button (MODE)**
- ⑥ **Test signal button (TEST)**
- ⑦ **Delay time adjust button (DELAY TIME)**

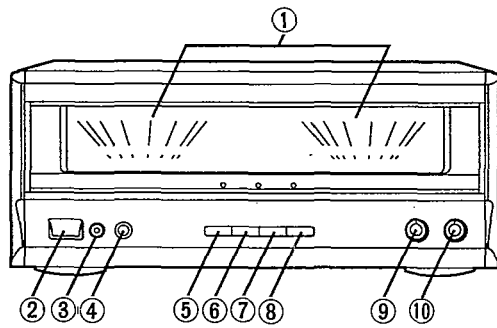

- ⑧ **Center mode select button (CENTER MODE)**
- ⑨ **Bass control (BASS)**
- ⑩ **Treble control (TREBLE)**

INSTALLATION

Stacking the components

Horizontal stacking **A**

- Ⓐ CD changer (SL-CA10)
- Ⓑ Tuner (ST-CA10)
- Ⓒ Cassette deck (RS-CA10)
- Ⓓ Amplifier (SE-CA10)

Vertical stacking **B**

- Ⓐ Tuner (ST-CA10)
- Ⓑ Amplifier (SE-CA10)
- Ⓒ CD changer (SL-CA10)
- Ⓓ Cassette deck (RS-CA10)

Placement of speakers **C**

As well as enjoying normal stereo reproduction with the left and right front speakers, a center speaker and surround speakers can also be connected to the unit in order to enjoy the sound performance of DOLBY PRO LOGIC Systems.

We recommend that surround speakers be placed on the side of or slightly behind the listener, and about one meter higher than ear level.

However the position should be adjusted to your personal preference, because the effect varies to some degree depending upon the type of music and the music source.

- Ⓐ Front speaker (Left) (SB-CA10)
- Ⓑ Center speaker (SB-PC10)
- Ⓒ TV (not included)
- Ⓓ This system
- Ⓔ Front speaker (Right) (SB-CA10)
- ① Surround speaker (Left) (SB-PS10)
- ② Surround speaker (Right) (SB-PS10)

Caution

Use these speakers only with the recommended system. Failure to do so may lead to damage to the amplifier and/or the speaker, and may result in the risk of fire. Consult a qualified service person if damage has occurred or if you experience a sudden change in performance.

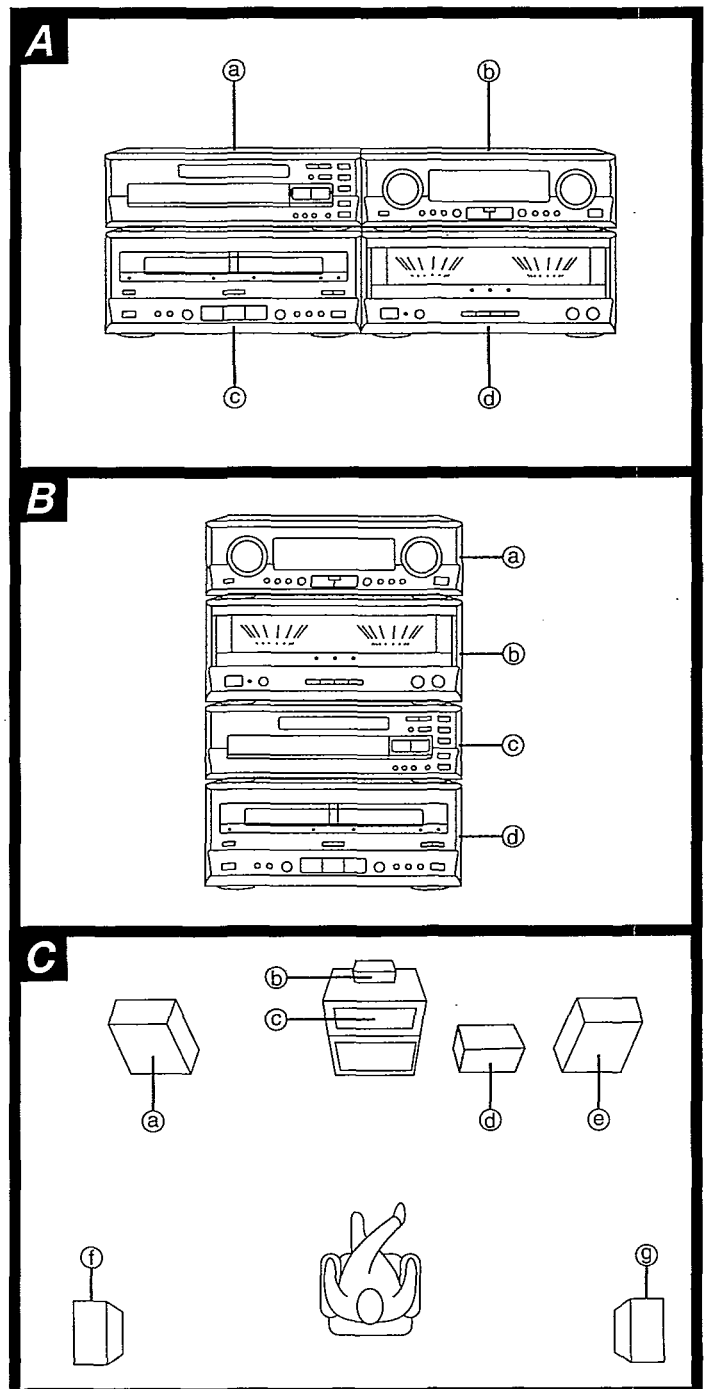

CONNECTIONS

• Flat cable (included) connections

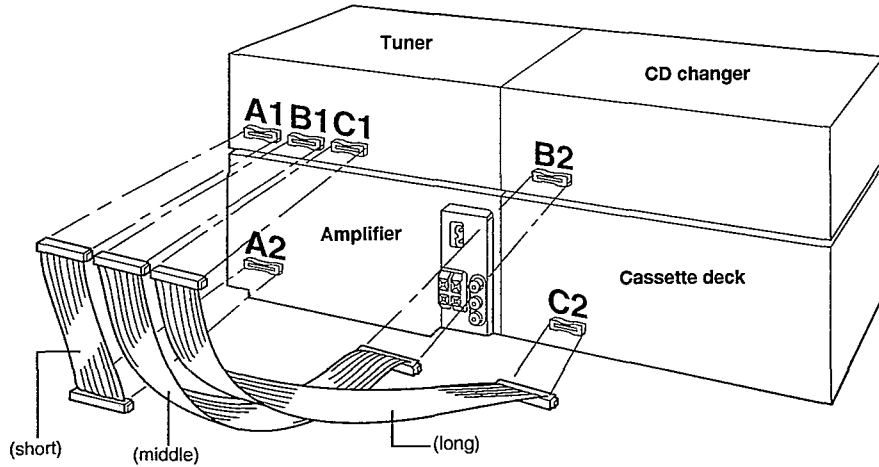

Before making connections:

Make sure the white line on the cable is on the right side.

To unplug cables:

Hold the connector from both ends.

Note Do not try connecting or disconnecting the flat cables while the power is switched to ON.

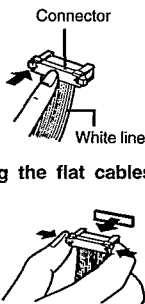

After connection:

Fold and press the cable as flat to the back of the unit as possible. (To minimize noise pickup while listening an MW/LW broadcast)

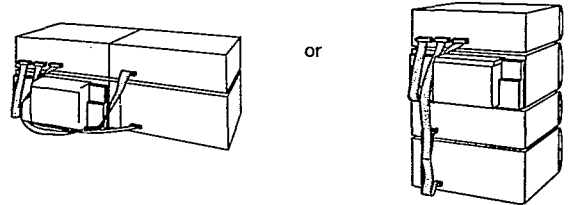

• Antenna connections

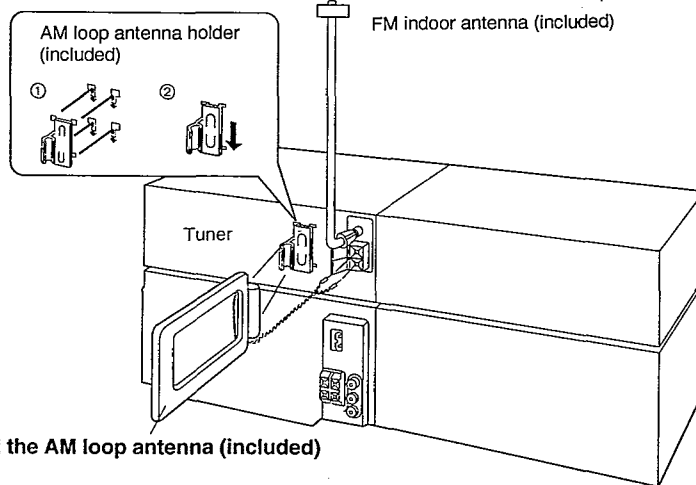

How to install the AM loop antenna (included)

① Strip off the outer covering.

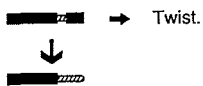

② Insert the wire.

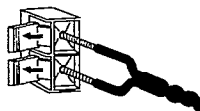

③ Close the lever.

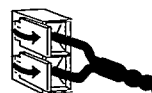

④ Attach the AM loop antenna to the

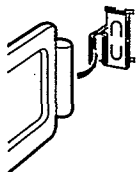

Note

- To minimize noise pickup, bundle the loop antenna cord using a tape or so to keep the flat cables away from the AM loop antenna cord.
- You may attach the antenna holder to a rack or other structure.

• When mounting the antenna to a column or rack

AM loop antenna holder (included)

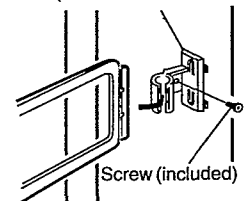

● Connection of front and surround speakers

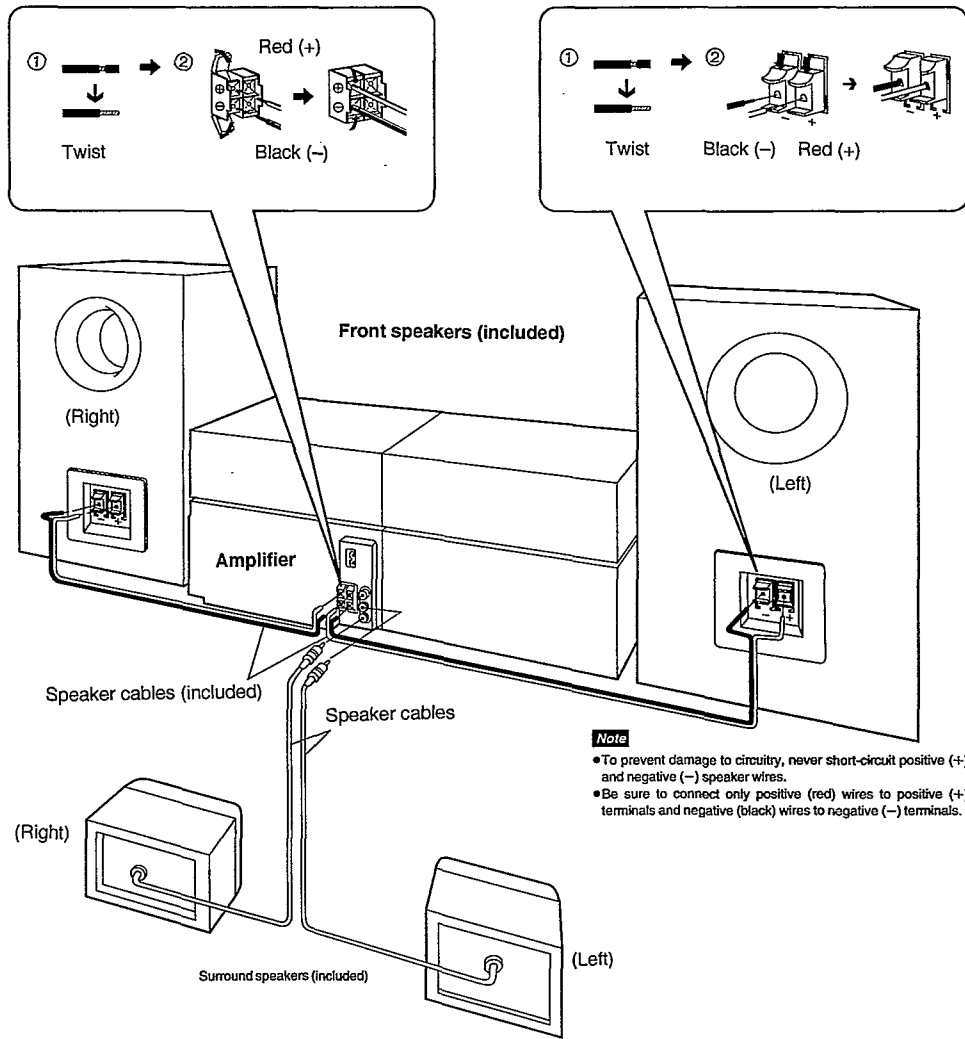

● Connection of center speaker

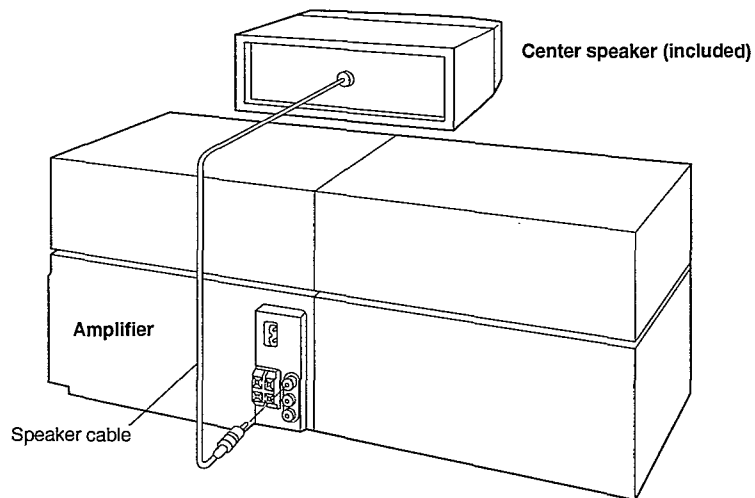

● **Connection of AC power supply cord**

- Plug the cord into an outlet only after all other connections have been made.

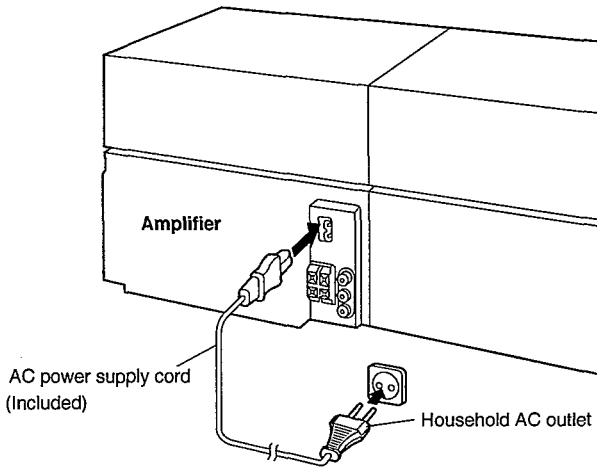

[For (EB) area only]

BE SURE TO READ THE CAUTION FOR AC POWER SUPPLY CORD ON PAGE 3 BEFORE THE FOLLOWING CONNECTIONS.

[For (GC) area only]

Set the voltage selector to the voltage setting for the area in which the unit will be used.

[Use a minus (-) screwdriver]

Note

If the power supply in your area is 117 V or 120 V, set to the "127 V" position.

Note that this unit will be seriously damaged if this setting is not made correctly.

If the power plug will not fit your socket, use the power plug adapter (included).

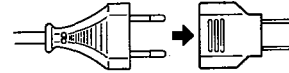

[For (E, EG, GN) areas.]

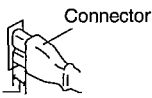

Insertion of Connector:

Approx. 6mm

Even when the connector is perfectly inserted, depending on the type of inlet used, the front part of the connector may jut out as shown in the drawing. However there is no problem using the unit.

● **Optional antenna connections**

FM outdoor antenna (not included)

The outdoor antenna should be used when using this unit in mountainous areas or in spaces enclosed by reinforced concrete where the FM indoor antenna (included) does not provide satisfactory reception.

Note

An outdoor antenna should be installed by a qualified technician only.

AM (MW/LW) outdoor antenna (not included)

B

The outdoor antenna should be used when using this unit in mountainous areas or in spaces enclosed by reinforced concrete where the AM loop antenna (included) does not provide satisfactory reception.

Use 5–12 m of vinyl-sheathed wire horizontally at the window, or a convenient location.

When the unit is not in use, disconnect the outdoor antenna to prevent possible damage from lightning. Never use an outdoor antenna during an electrical storm.

Note

Be sure to connect the AM loop antenna even when an outdoor antenna is used.

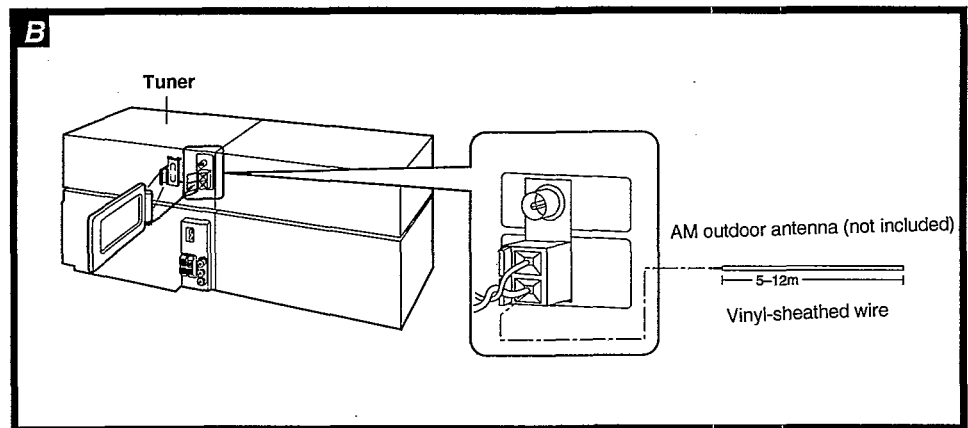
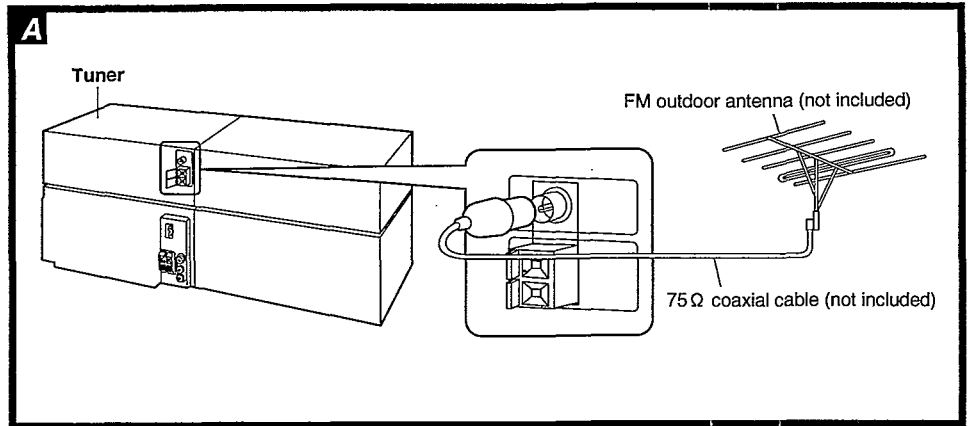

● External unit connections

- Make sure that the power supply for all components has been turned off before making any connections.
- For details, refer to the operating instructions of the units which are to be connected.
- All peripheral components and cables sold separately.

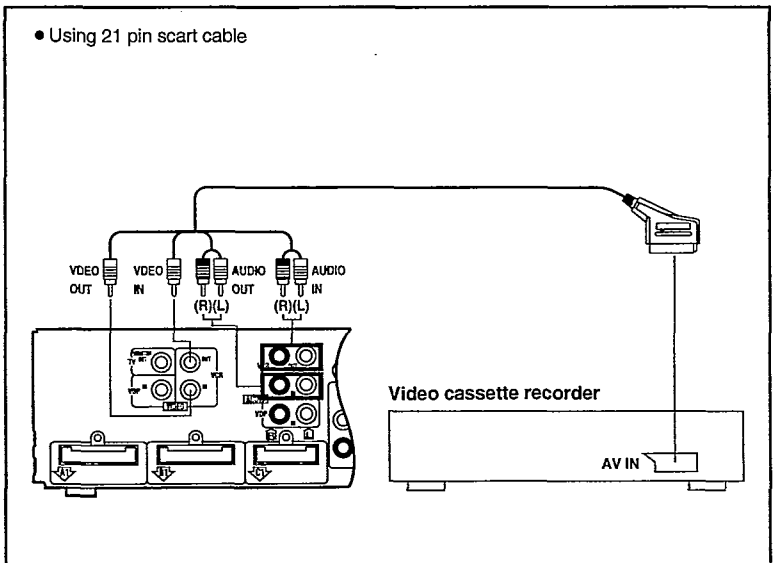
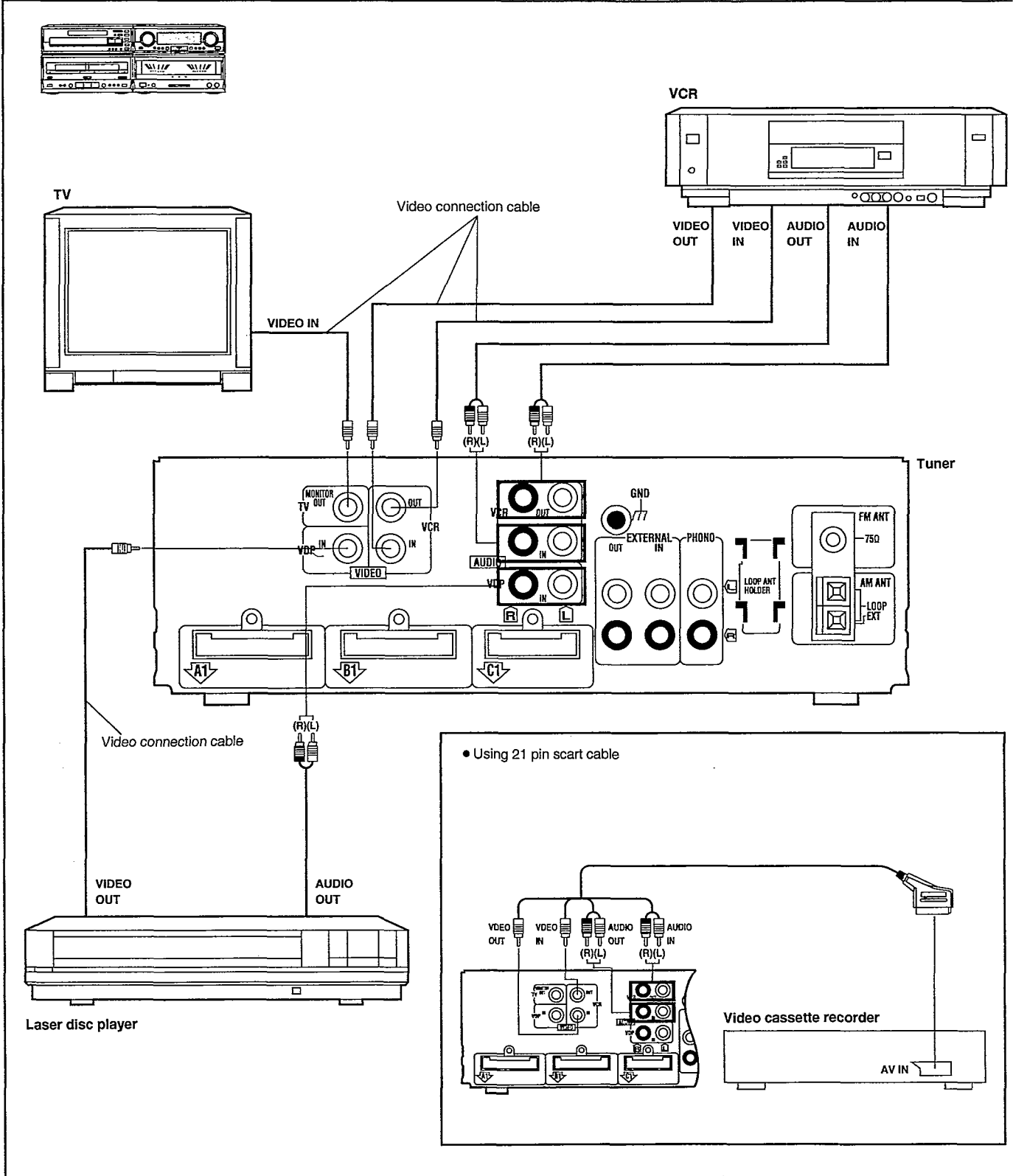
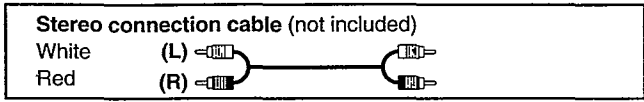

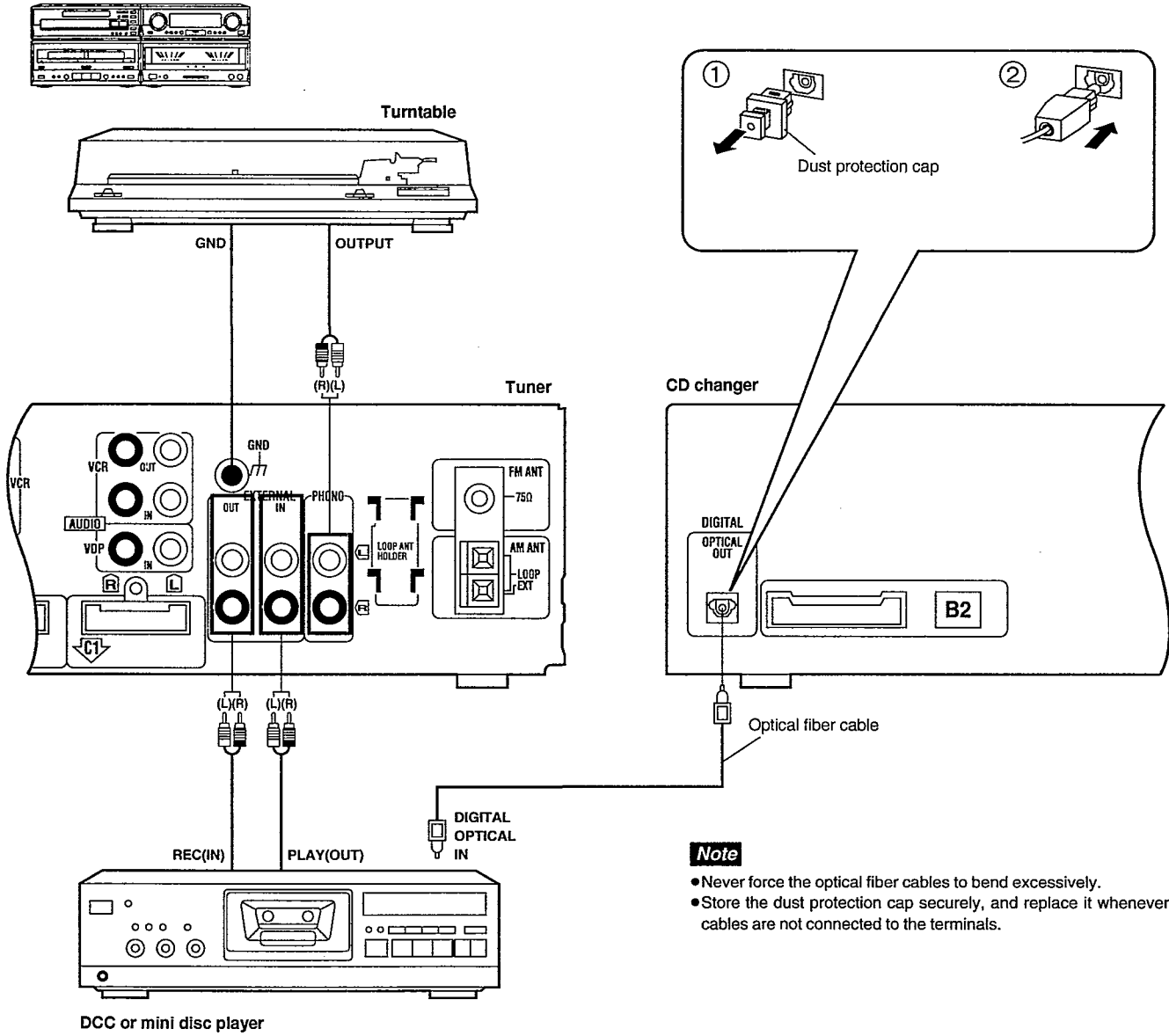

■ USING THE DOLBY PRO LOGIC SURROUND

By combining front, center and surround speakers, you can enjoy the SURROUND mode which conveys a feeling of presence or the 3 STEREO mode which conveys a feeling of orientation.

SURROUND

By reproducing the feeling of depth and movement of sound, video software or compact discs recorded with Dolby Surround provide the listener with a feeling of presence like that of a movie theater.

To enjoy SURROUND, be sure to connect the surround speakers.

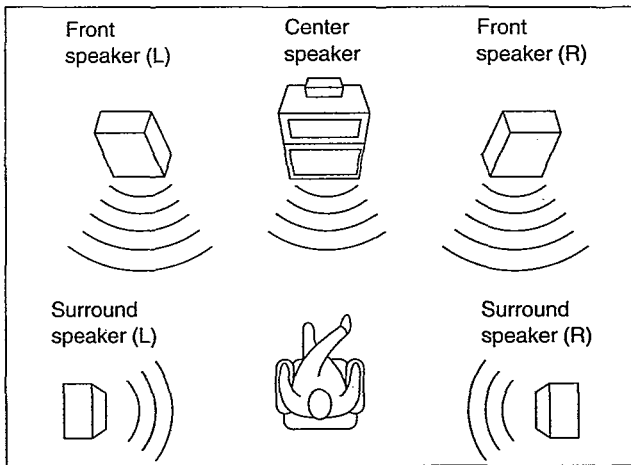

Setting the center mode

For Dolby Pro Logic systems, center mode setting is necessary to play back bass sounds effectively.

Set the center mode in accordance with the size of your center speaker.

- 1 Switch on the power.
- 2 Press **MODE** to select "SURROUND" or "3 STEREO". Each time you press the button, the display will change as follows:
SURROUND → 3 STEREO → OFF
- 3 Press **CENTER MODE** to select "NORMAL" mode. Each time you press the button, the display will change as follows:
NORMAL → WIDE → PHANTOM

Note

"PHANTOM" will not be displayed when you select "3 STEREO" in step 2.

NORMAL:

When the center speaker is smaller than the front speakers

WIDE:

When the center speaker is the same or larger size as the front speakers

PHANTOM: **SURROUND only**

When no center speaker is connected.

Note

In the PHANTOM mode, the sound which would have been sent to the center speaker will be divided equally between both the left and right front speakers.

3 STEREO

You can enjoy audio/video sources with clear sound, more presence and a good feeling of orientation. 3 STEREO can be used with sources not recorded in DOLBY SURROUND.

To enjoy 3 STEREO, be sure to connect the center speaker.

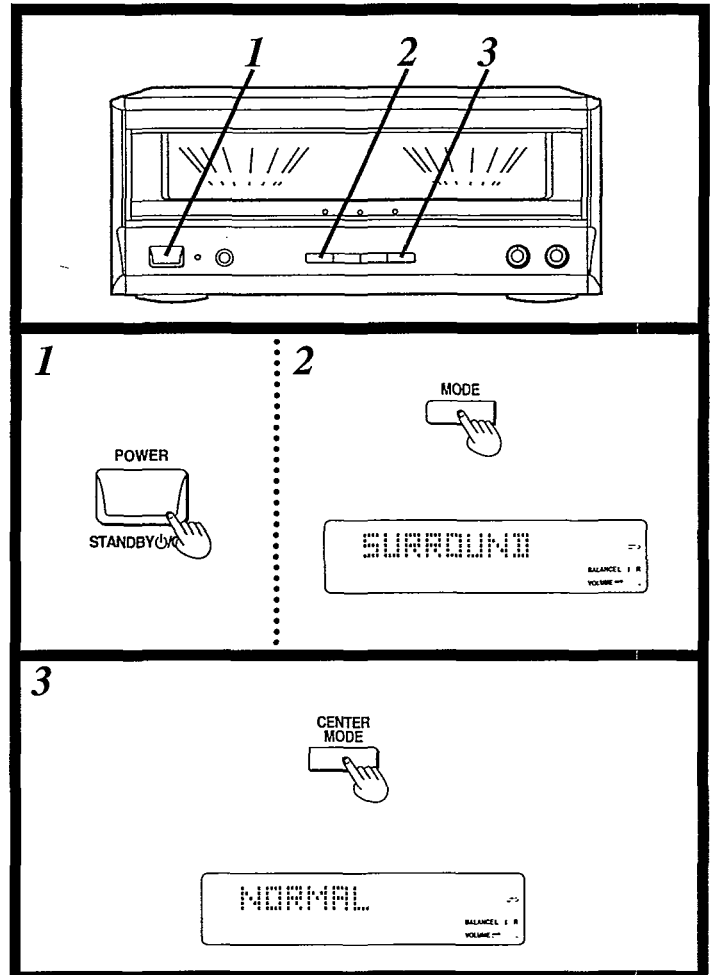
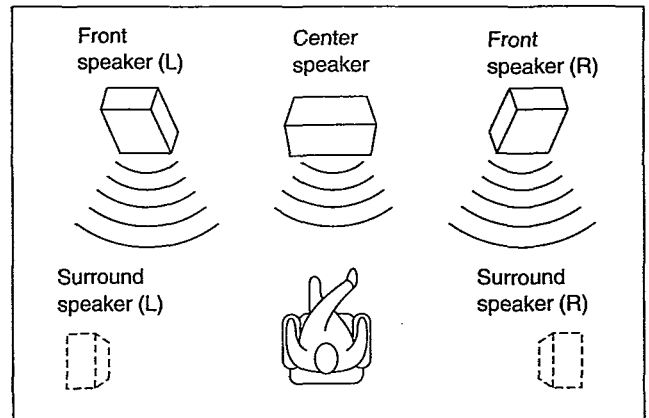

■ ADJUSTING SPEAKER OUTPUT LEVEL

In order to reproduce the movement of the sound and its clear orientation, it is important to adjust the output level of each speaker. Adjust output to the correct levels while listening to the test signal. Before starting, check your front speakers are correctly balanced.

1 Press **MODE** to select "SURROUND" or "3 STEREO".

2 Press **TEST** to output a test signal.

The test signal is emitted in the following order:

For SURROUND mode

Front speaker (left) → Center speaker



Surround speakers (left, right) ← Front speaker (right)

Note

The test signal is not emitted from the center speaker when the center mode is on PHANTOM.

For 3 STEREO mode

Front speaker (left) → Center speaker



Front speaker (right) ←

3 Turn **VOLUME** to set the volume level normally used for enjoying the source.

4 Press **CENTER (-) or (+) or SURROUND (-) or (+)** on the remote control to adjust the output level balance.

Adjust the output level of each speaker from the listening position until they are all identical.

Output levels can be varied within a range of ± 12 dB with front speaker output level serving as the zero point.

Note

- The test signal is output only by the speaker you are now adjusting and does not repeat the sequence until adjustments are complete.
- Remember you cannot adjust output level of the surround speakers if you selected the 3 STEREO mode in step 1.

To stop the test signal:

Press **TEST**.

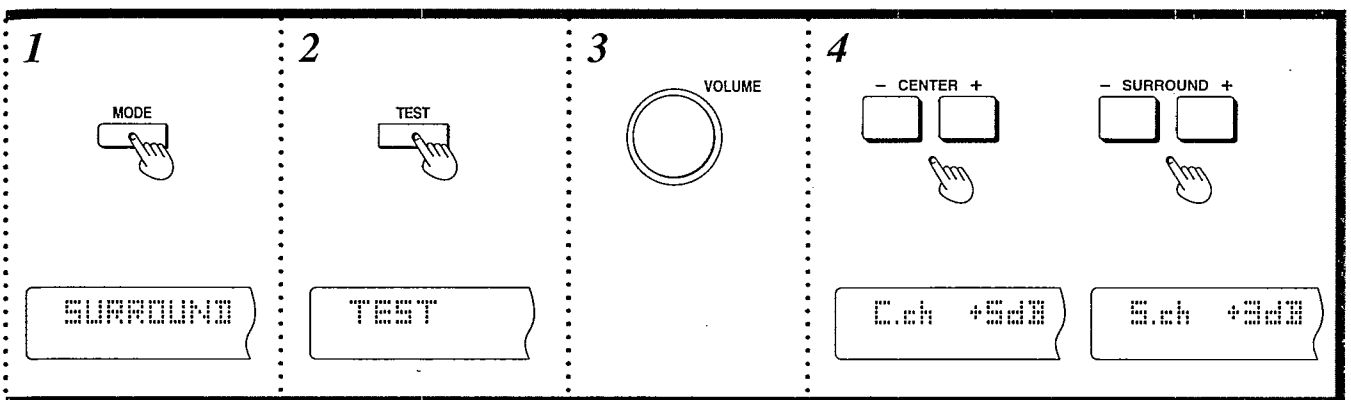
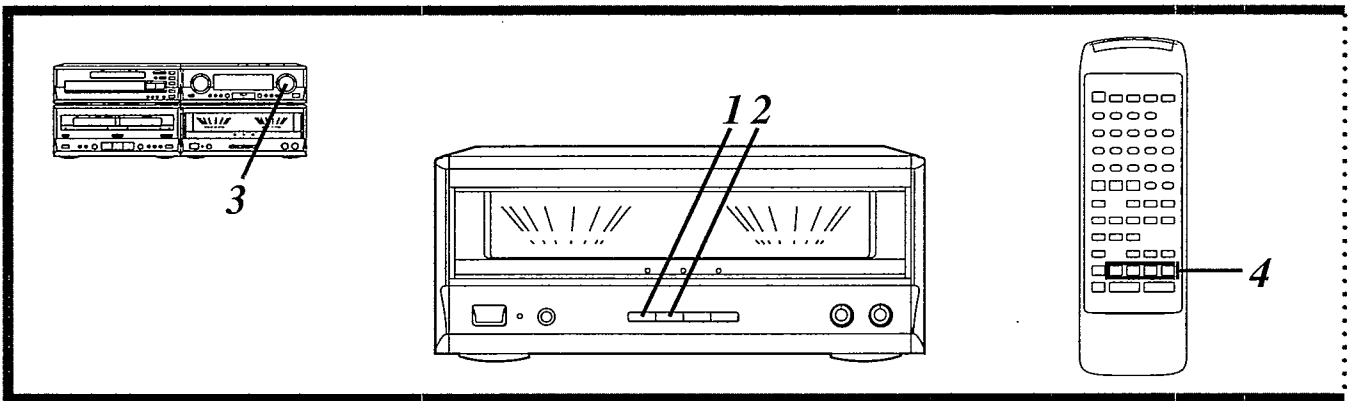

ADJUSTING THE DELAY TIME

When enjoying with SURROUND only

Adjust the sound from the surround speakers until the proper effect is produced.

- 1 Press **MODE** to select "SURROUND".
- 2 Press **DELAY TIME** to set to the suitable time.
When the button is pressed, the current delay time is displayed, pressing it again changes the delay time. Each time the button is pressed, the delay time will increase by 5 ms.

15 ms → 20 ms → 25 ms → 30 ms

To calculate the delay time, refer to the calculation methods.

The standard setting is 20 ms.

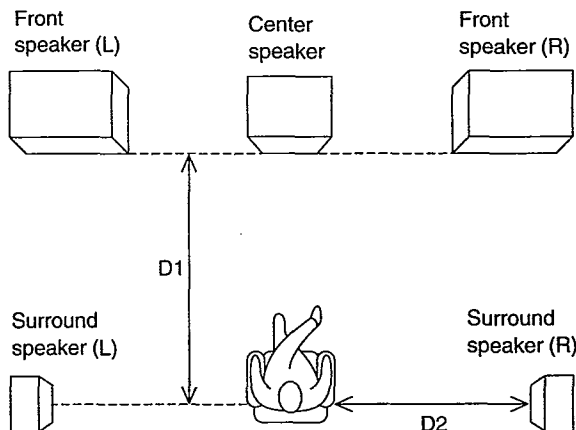

D1: Distance from front speakers
D2: Distance from surround speakers

If D1 is equal to or less than D2:

Set to 15 ms.

If D2 is less than D1:

Start at 15 ms and increase by 5 ms for every 1.5 m of difference between D1 and D2.

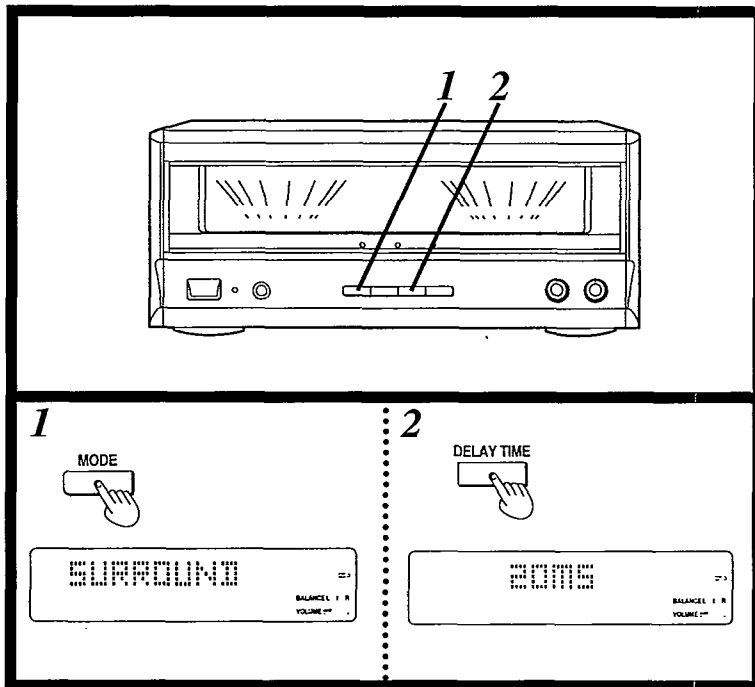

ENJOYING WITH SURROUND OR 3 STEREO

Before trying anything, have you set the center mode and adjusted speaker output level and adjusted the delay time?

When viewing a video, turn on the power supply for the TV and set the TV to video mode.

- 1 Press **MODE** to select "SURROUND" or "3 STEREO".
- 2 Press **INPUT SELECTOR** to select the desired external source.

Each time you press this button, sound sources will be switched as follows.

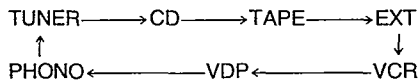

These indications correspond to terminals on the tuner's rear panel. Switch the displayed indication to the source you want to use.

Note

You can not enjoy SURROUND or 3 STEREO in the tuner mode.

- 3 Start the desired source.

To operate external sources, see the instruction manual provided with the specific unit.

Note

When employing SURROUND, use software recorded in Dolby Surround.

Note

You cannot record acoustical effects produced in the SURROUND and 3 STEREO modes.

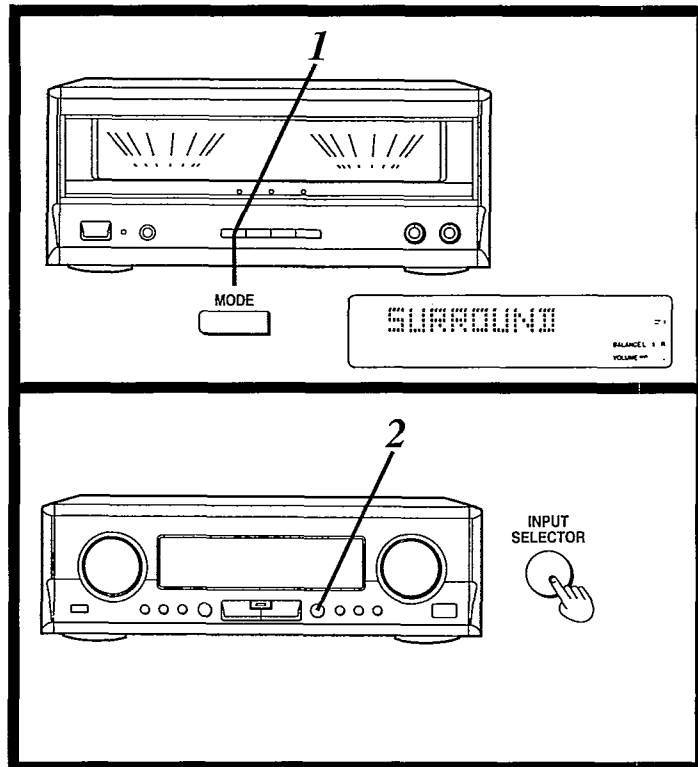

To turn off the DOLBY PRO LOGIC systems:

Press **MODE** to select "OFF".

Operation Check and Main Component Replacement Procedures

NOTE

1. This section describes procedures for checking the operation of the major printed circuit boards and replacing the main components.
2. For reassembly after operation checks or replacement, reverse the respective procedures. Special reassembly procedures are described only when required.
3. Select items from the following index when checks or replacement are required.
4. Illustrated screws are equivalent to actual size.
5. Refer the parts No. on the page of "Main Component Replacement Procedures", if necessary.

Contents

•Checking Procedures for each P.C.B.

Page.

- | | | |
|---------------------------------------|-------|-----|
| 1. Checking for the operation P.C.B.. | | 13. |
| 2. Checking for the main P.C.B.. | | 14. |

•Main Component Replacement Procedures

- | | | |
|---|-------|--------|
| 1. Replacement for the power IC and regulator transistor. | | 14,15. |
| 2. Replacement for the meter unit. | | 15. |

Checking Procedure for each P.C.B.

1. Checking for the operation P.C.B.

- a** (Black)
[RHD30007-K1]
- b** (Black)
[XTBS3+10JFZ1]
- c** (Black)
[XTBS3+8JFZ1]

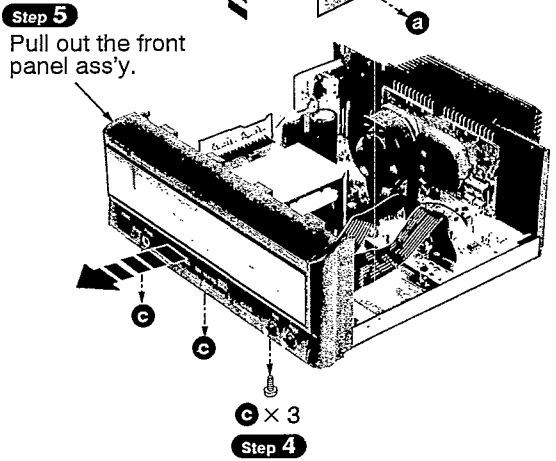
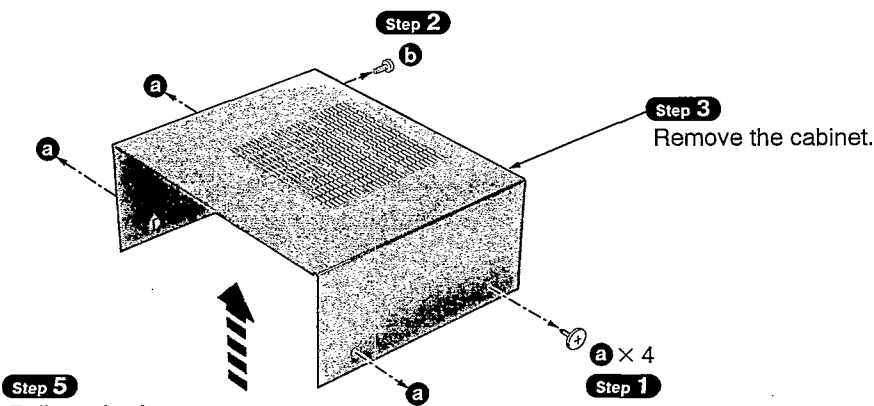

• Check the operation P.C.B. as shown below.

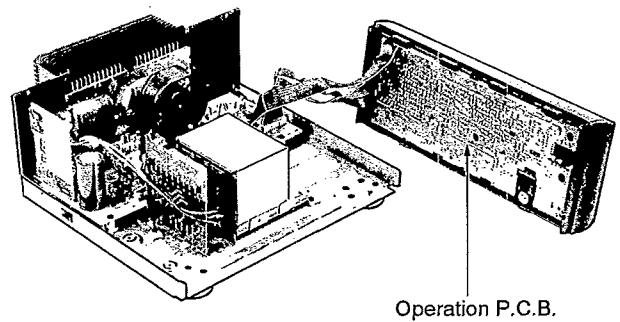

2. Checking for the main P.C.B.

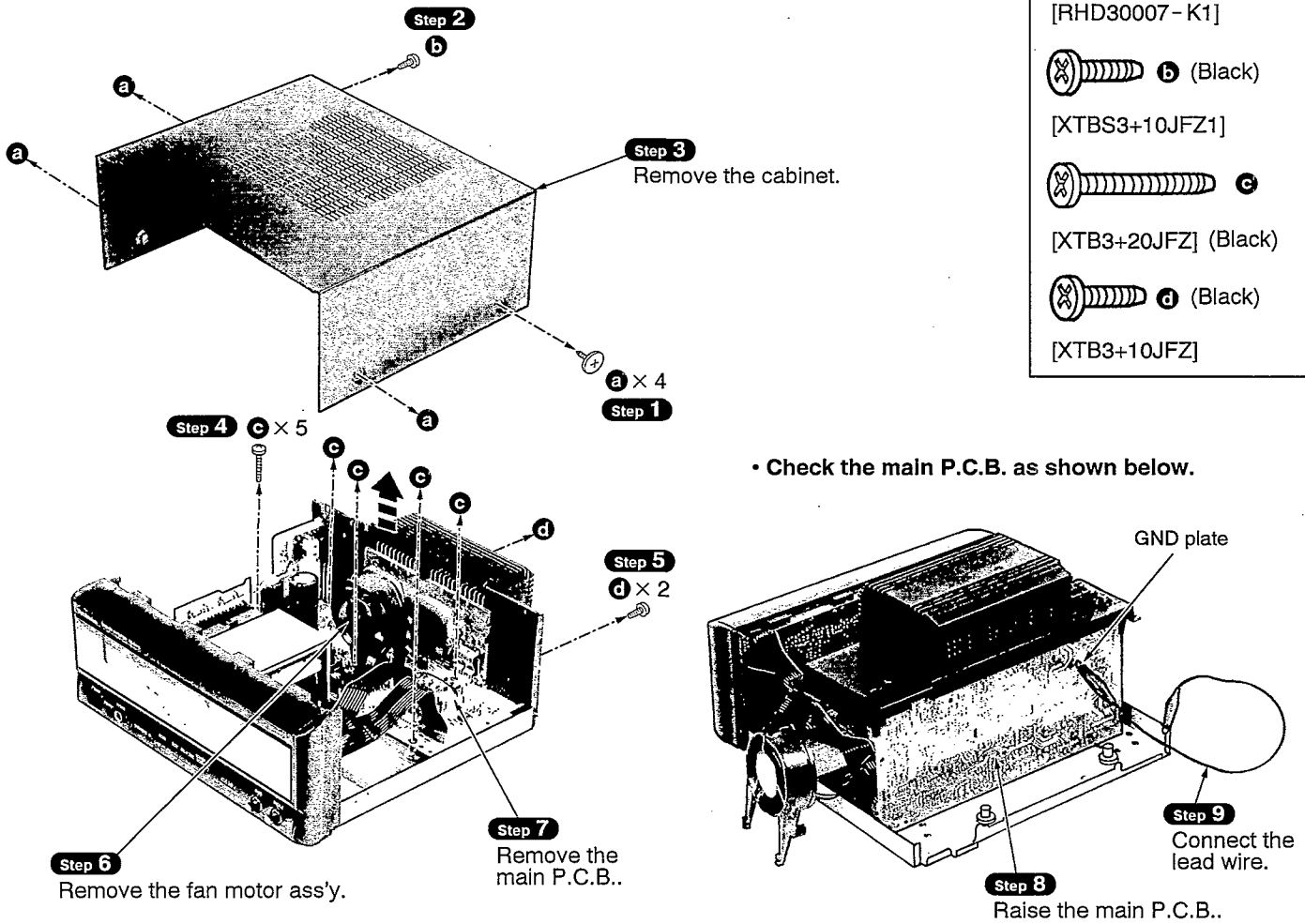

■ Main Component Replacement Procedures

1. Replacement for the power IC and regulator transistor

• Follow the item 2 (**Step 1** ~ **Step 7**) checking procedures for each P.C.B..

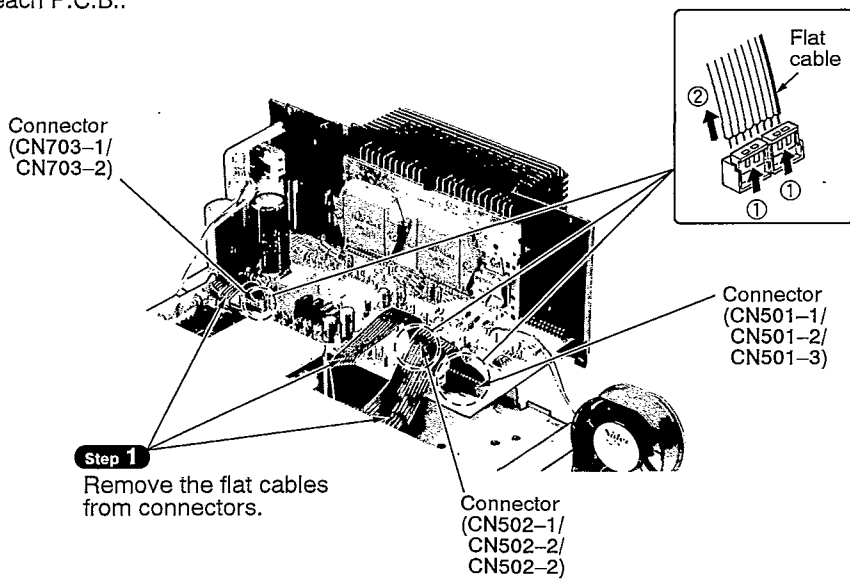

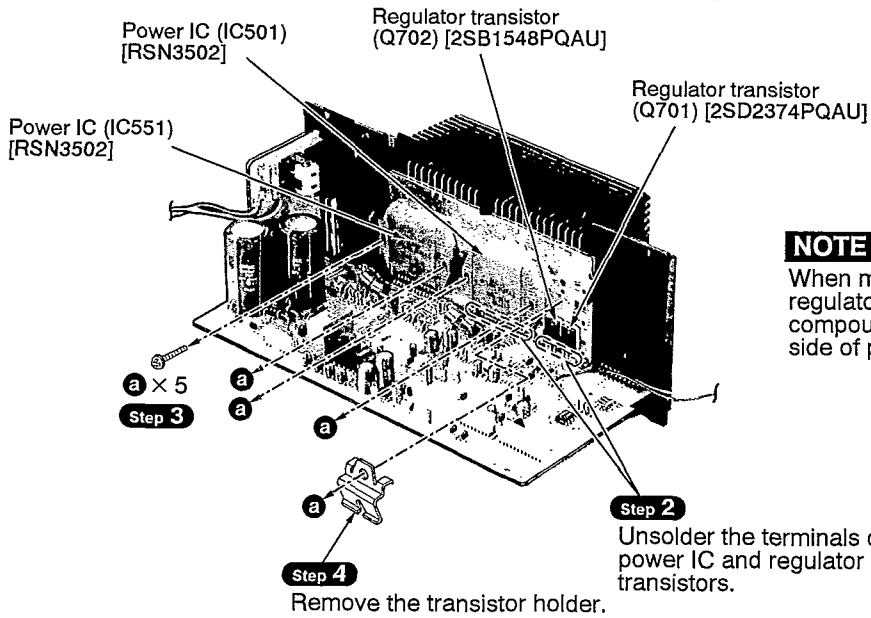
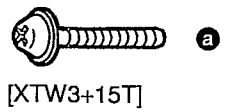

NOTE
When mounting the power IC or regulator transistor, apply silicone compound (RFKX0002) to the rear side of power IC or regulator transistors.

2. Replacement for the meter unit

• Follow the item 1 (**Step 1** ~ **Step 5**) checking procedures for each P.C.B..

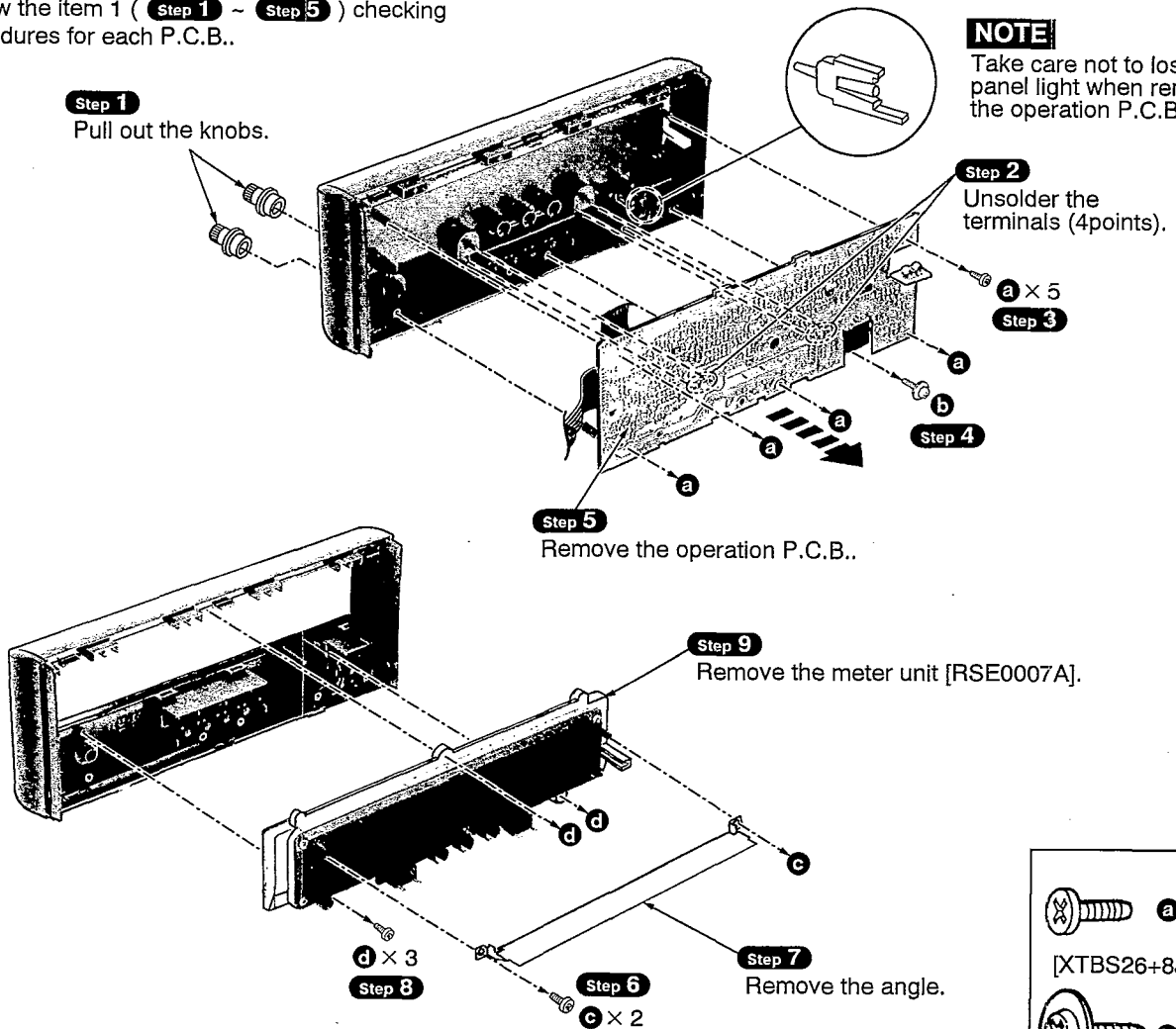

NOTE
Take care not to lose the panel light when removing the operation P.C.B..

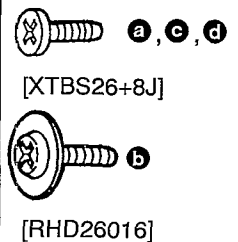

REPLACEMENT OF THE FOOT

1. Remove the 4 heat melted posts on the Bottom chassis ass'y with a pair of nippers or similar tool.
2. To replace the foot (RKA0011-3) on the bottom chassis ass'y melt the 4 posts with a soldering iron.

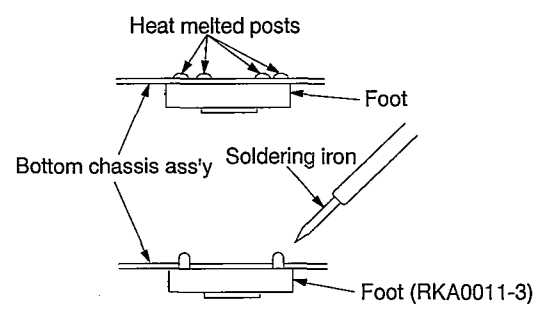

POWER SOURCE ON/OFF OF THIS UNIT

1. Connect this unit to an AC outlet by the AC power cord.
(This unit comes to stand-by mode.)
2. Short the test point **TP701** in Fig. 1.
This unit comes to power ON mode.

Operation check

1. Set this unit to power ON mode.
2. Input a signal (1kHz, 100mV), and confirm it to be outputted from the speaker terminal.

	INPUT	OUTPUT
Lch	J603-J308	Lch speaker terminal
Rch	J604-J308	Rch speaker terminal
Surround	J611-J308	Surround speaker terminal (To output a signal, both Lch and Rch should be connected.)
Center	J612-J308	Center speaker terminal

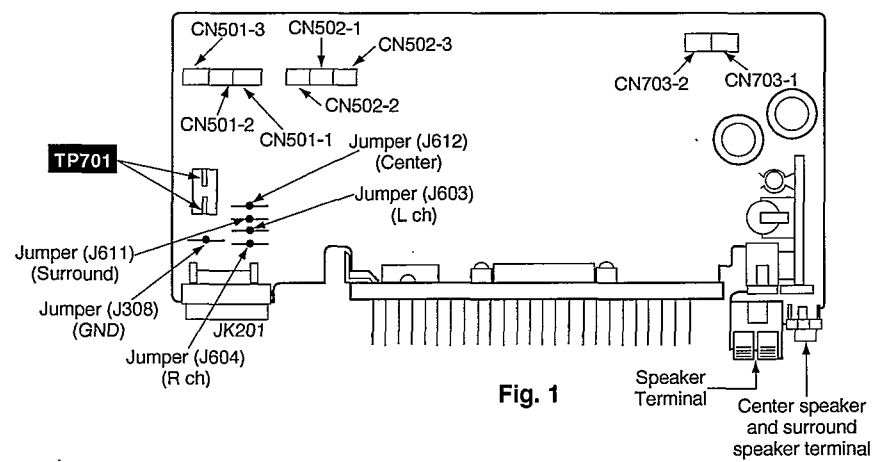

MEASUREMENTS AND ADJUSTMENTS

Caution: Before adjustment, be sure to connect this unit through the tuner (ST-CA10).

Control positions and equipment used.

- BASS, TREBLE knob Center
- Input selector (ST-CA10) AUX
- AF Oscillator
- AC electronic voltmeter (EVM)

POWER METER ADJUSTMENT

1. Connect an AF oscillator and AC EVM to the amplifier, as shown in Fig. 1.
2. Set the power meter input level to 0 and confirm the meters on both amplifiers, L ch and R ch, show **-60dB**.
3. Turn on power to the unit and apply a **1kHz 50mV** signal from pin ③ (GND) to pin ④ (R ch) and pin ⑤ (L ch) of W501.
With this input level applied, check the AC EVM monitor are within the range of **±3mV**.
4. Adjust **VR808** (R ch) and **VR809** (L ch) so that the power meter indicates **1W**, as shown in Fig.2.
5. Increase the input level by **10dB** and confirm that the power meter indicates **10W (±1.5W)**.
6. Set the input level back to **0** and check the meter indicators do not return to **-60dB** too quickly or unevenly.

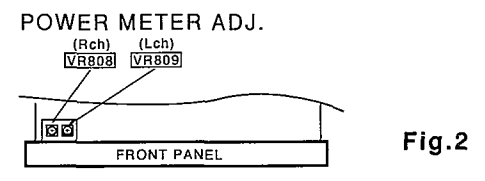
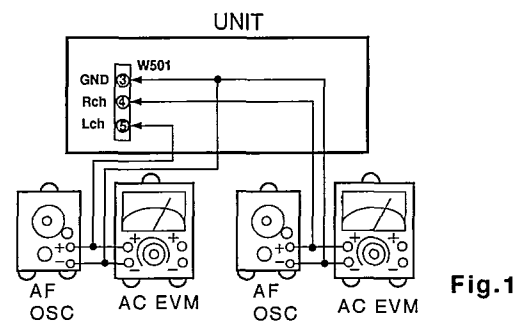

SCHEMATIC DIAGRAM

• This schematic diagram may be modified at any time with the development of new technology.

	Page
A OPERATION CIRCUIT	18, 19
B HEADPHONES JACK	18
C MAIN CIRCUIT	20, 21
D POWER TRANSFORMER CIRCUIT [For (E, EB, EG, GN) areas]	21
[For (GC) area]	17
E AC IN TERMINAL CIRCUIT [For (E, EB, EG, GN) areas]	17
F VOLTAGE SELECTOR CIRCUIT [For (GC) area]	17

Notes:

- **S701:** Voltage adj. switch in "220V" position. (110V ↔ 127V ↔ 220V ↔ 240V) [For (GC) area only]
- **S801:** Power "STANDBY \odot /ON" switch (POWER, STANDBY \odot /ON)
- **S802:** DOLBY PRO LOGIC mode select switch (MODE)
- **S803:** Test signal switch (TEST)
- **S804:** Delay time adjust switch (DELAY TIME)
- **S805:** Center mode select switch (CENTER MODE)
- Indicated voltage values are the standard values for the unit measured by the DC electronic circuit tester (high-impedance) with the chassis taken as standard. Therefore, there may exist some errors in the voltage values, depending on the internal impedance of the DC circuit tester.
No mark: Power ON
- Important safety notice:
Components identified by \triangle mark have special characteristics important for safety.
Furthermore, special parts which have purposes of fire-retardant (resistors), high-quality sound (capacitors), low-noise (resistors), etc. are used.
When replacing any of components, be sure to use only manufacturer's specified parts shown in the parts list.
- **Caution!**
IC and LSI are sensitive to static electricity.
Secondary trouble can be prevented by taking care during repair.
Cover the parts boxes made of plastics with aluminum foil.
Ground the soldering iron.
Put a conductive mat on the work table.
Do not touch the legs of IC or LSI with the fingers directly.

Voltage and signal line

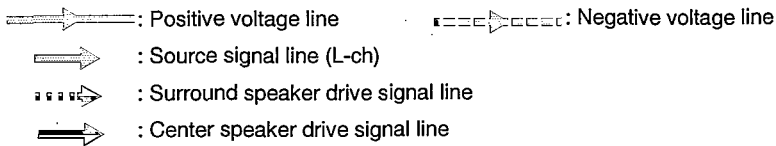

Power Source For [GC] area. (P.C.Board: on page 24)

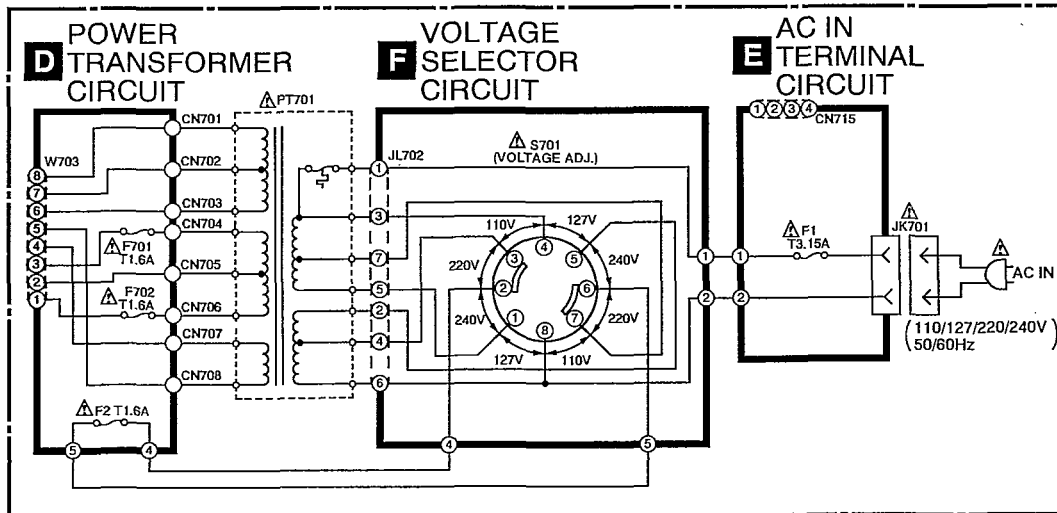

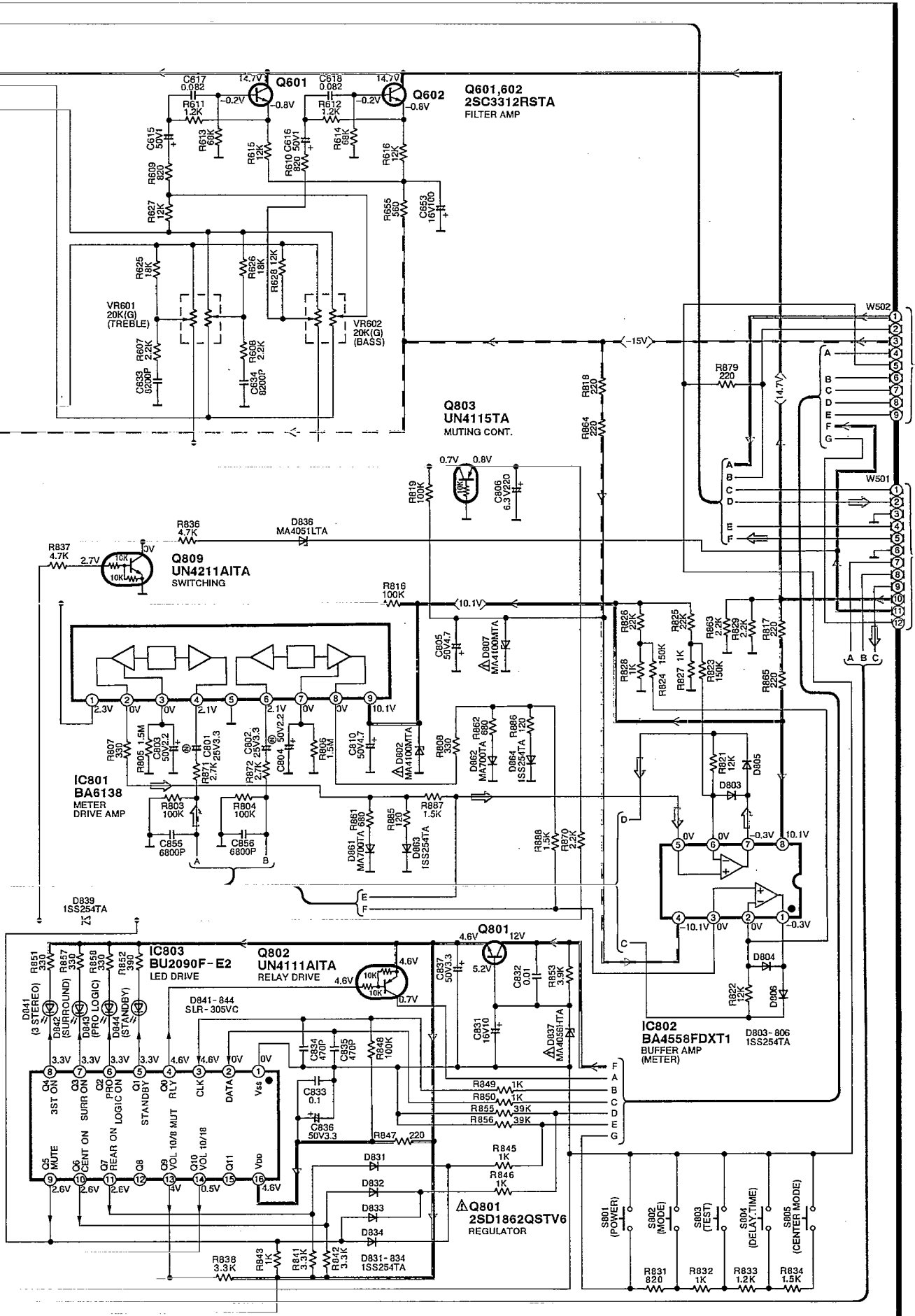

C MAIN CIRCUIT (P.C.Board: on page 22)

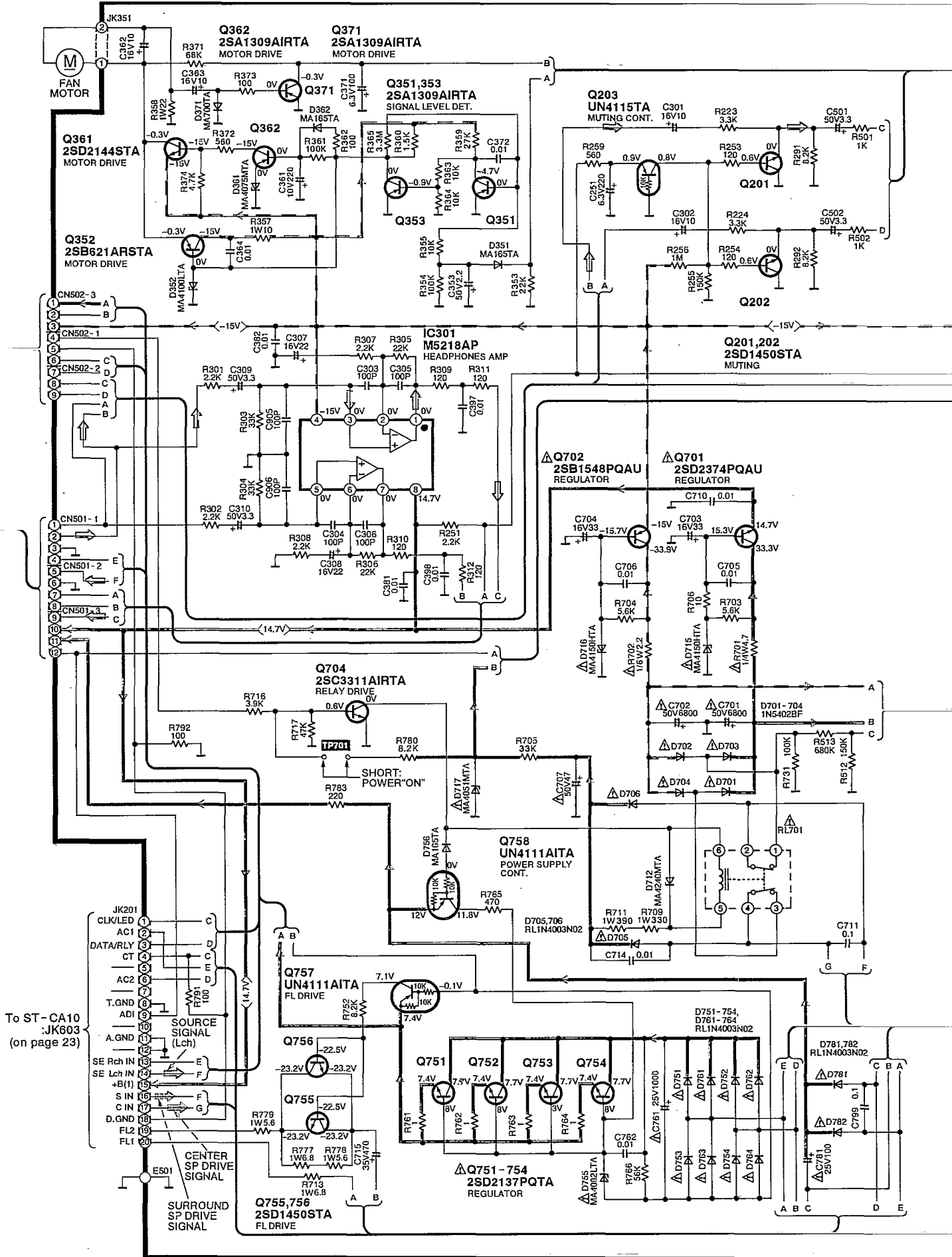

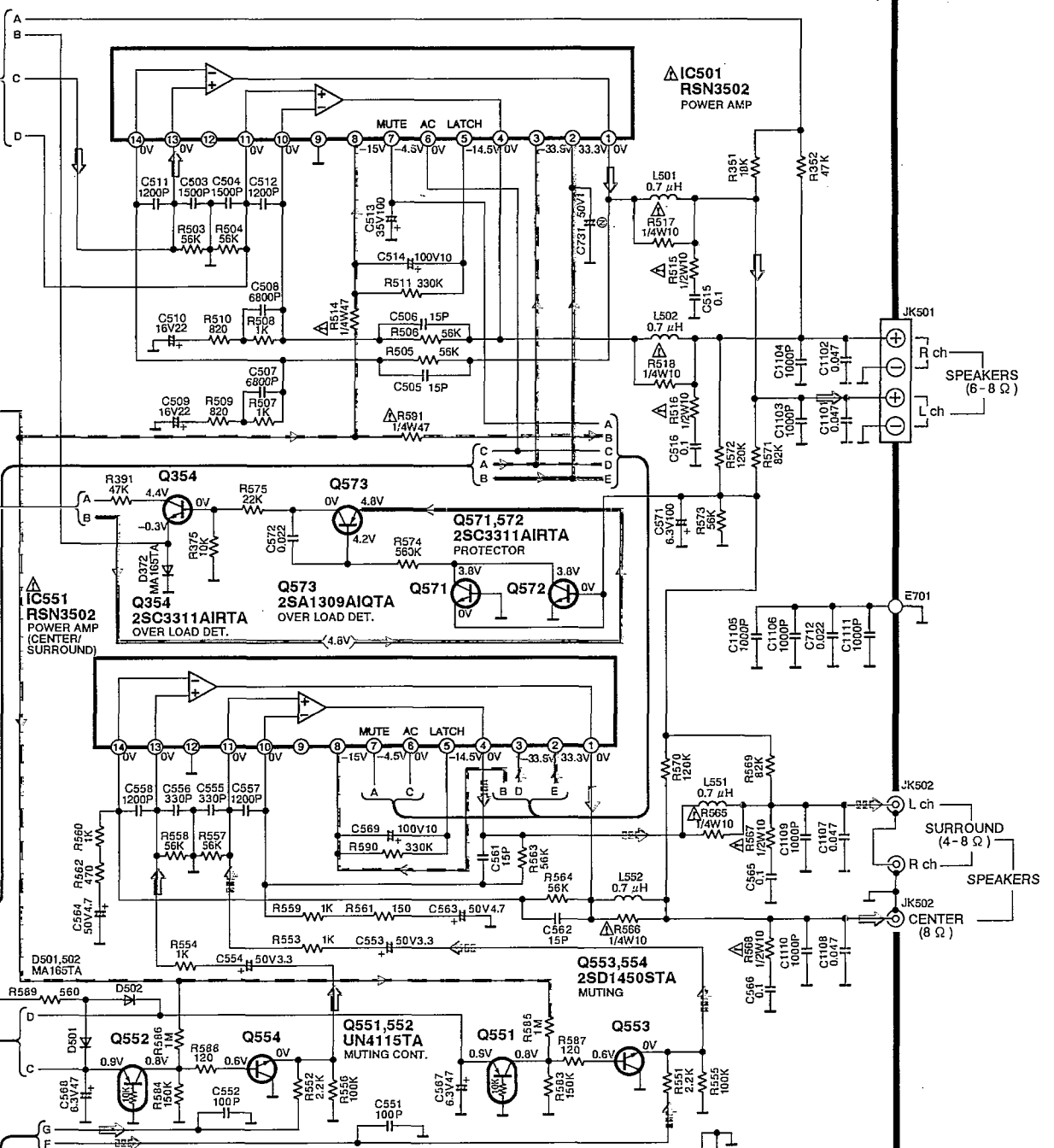

**D POWER TRANSFORMER
CIRCUIT (P.C.Board: on page 23)**

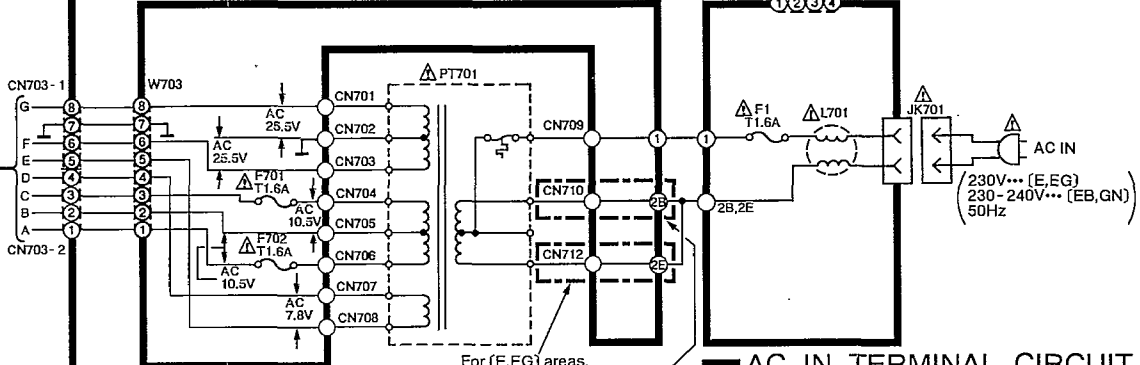

**E AC IN TERMINAL CIRCUIT
(P.C.Board: on page 23)**

Power Source P.C.B. For [GC] area.

D POWER TRANSFORMER P.C.B. (REP2152B-P)

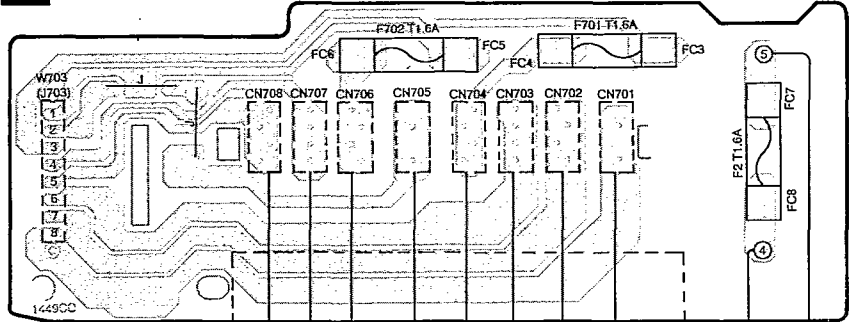

E AC IN TERMINAL P.C.B. (REP2152B-P)

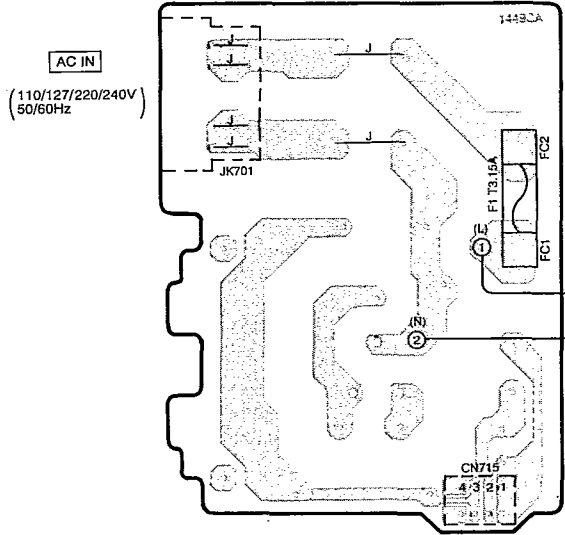

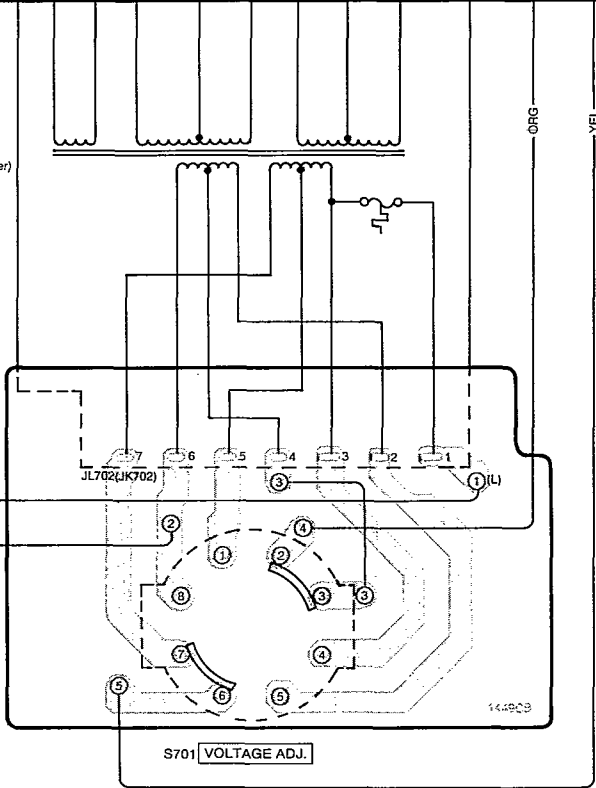

PT701 (Power transformer)

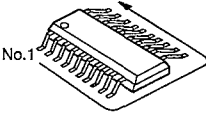
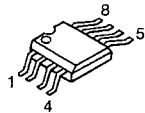
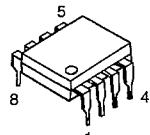
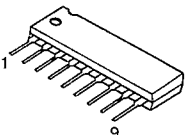
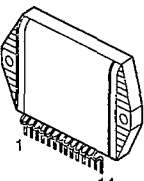

F VOLTAGE SELECTOR P.C.B. (REP2152B-P)

● Terminal guide of IC's, transistors and diodes

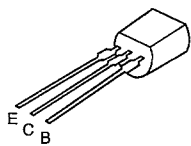
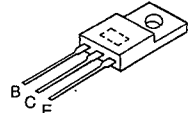
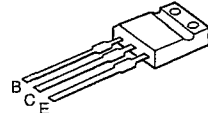
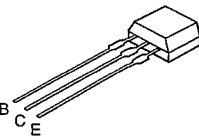
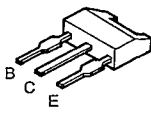
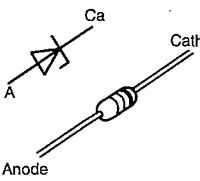
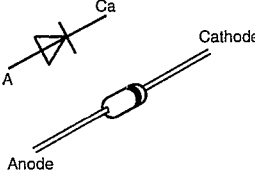
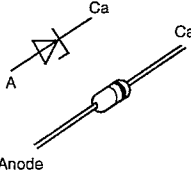
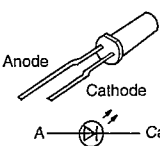
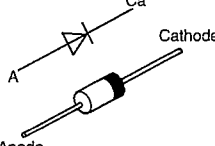
 <table border="1" data-bbox="418 181 673 286"> <tr> <td>M5219FPPTA</td> <td>8PIN</td> </tr> <tr> <td>MC14066BFEL</td> <td>14PIN</td> </tr> <tr> <td>BU2090F-E2</td> <td>16PIN</td> </tr> </table>		M5219FPPTA	8PIN	MC14066BFEL	14PIN	BU2090F-E2	16PIN	 <p>BA4558FDXT1</p>	 <p>M5218AP</p>	 <p>BA6138</p>
M5219FPPTA	8PIN									
MC14066BFEL	14PIN									
BU2090F-E2	16PIN									
 <p>RSN3502</p>	 <p>2SA1309AIQTA 2SA1309AIRTA 2SC3311AIRTA 2SC3312RSTA 2SD1450STA UN4111AITA UN4115TA UN4211AITA</p>	 <p>2SB621ARSTA</p>	 <p>2SB1548PQAU 2SD2374PQAU</p>	 <p>2SD2137PQTA</p>						
 <p>2SD2144STA</p>	 <p>2SD1862QSTV6</p>	 <p>MA4051LTA MA4051MTA MA4056HTA MA4068HTA MA4075MTA MA4082LTA</p>	 <p>1SS254TA MA165TA MA700TA</p>							
 <p>MA4100MTA MA4100LTA MA4150HTA MA4240MTA</p>	 <p>SLR-305VC</p>	 <p>1N5402BF RL1N4003N02</p>								

■ WIRING CONNECTION DIAGRAM

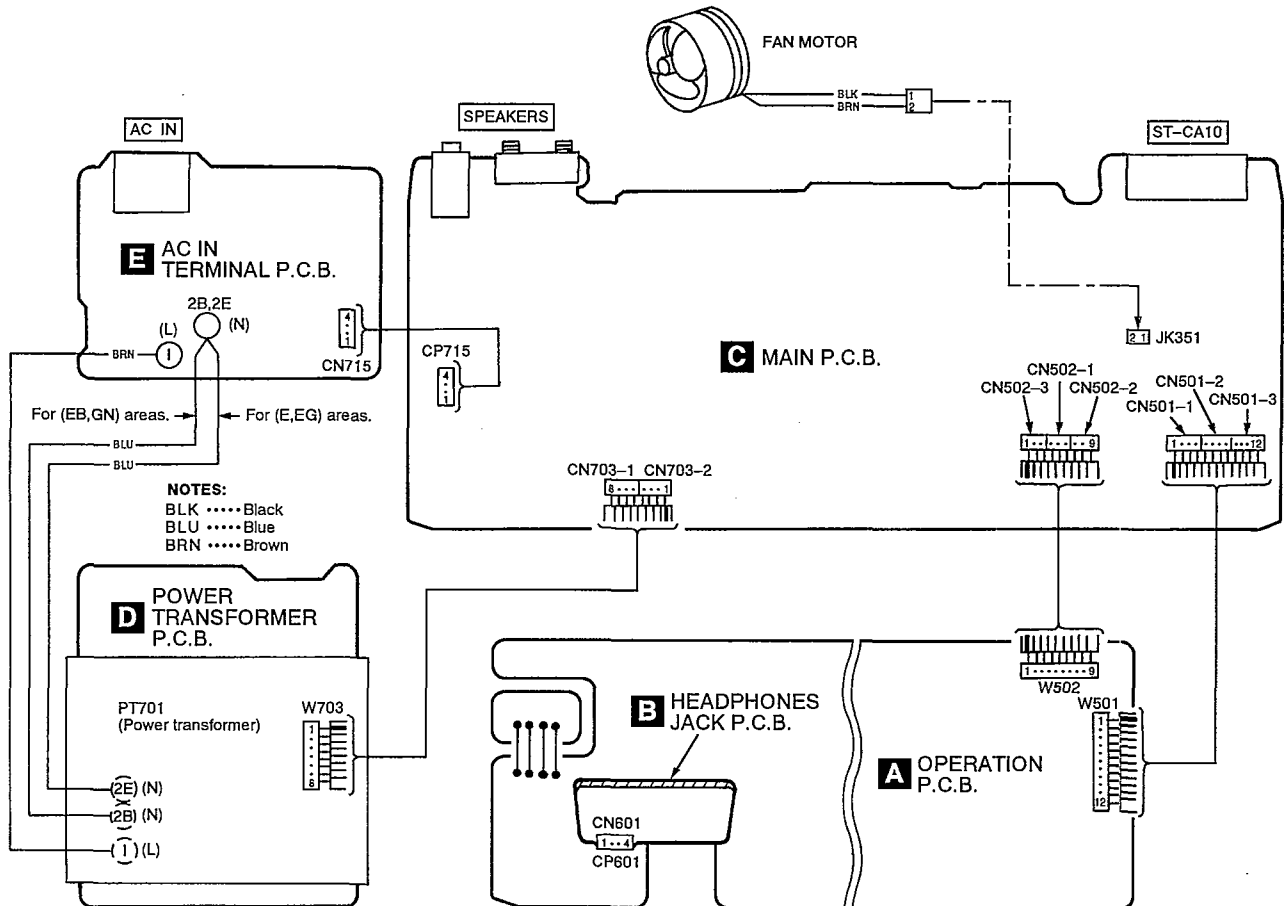

• Signal line \longrightarrow : Source signal \dashrightarrow : Surround speaker drive signal \Rightarrow : Center speaker drive signal

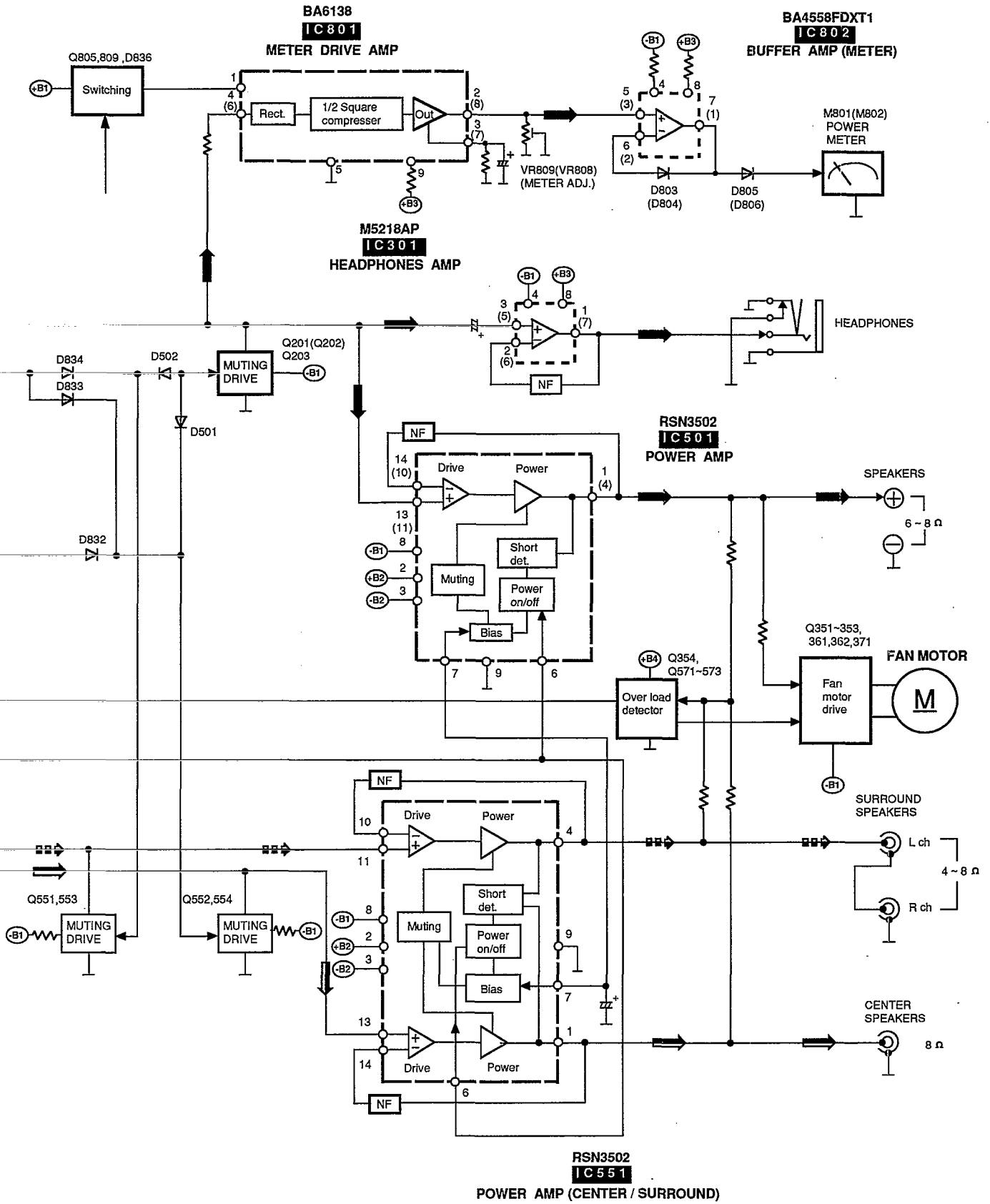

CABINET PARTS LOCATION

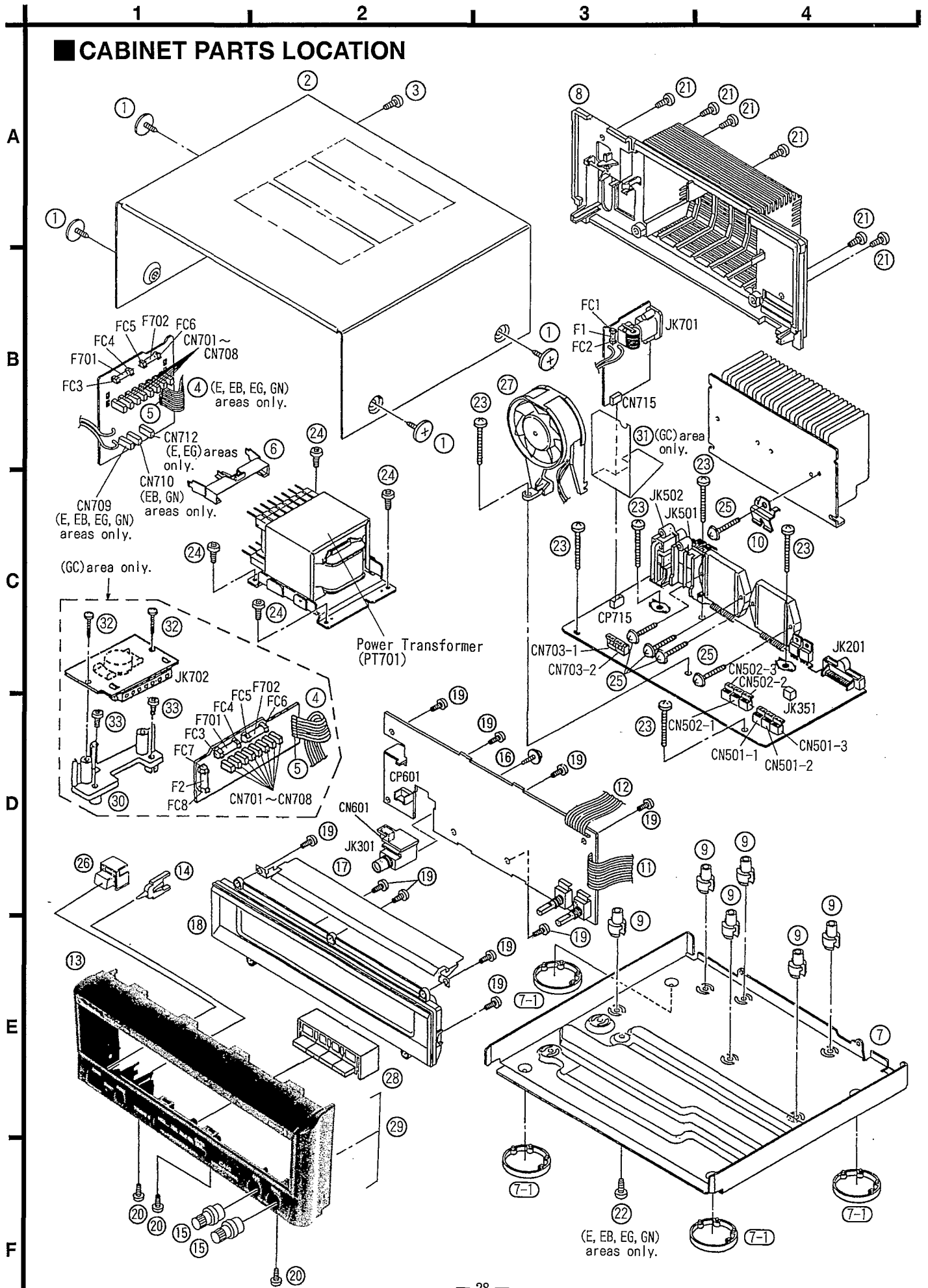

REPLACEMENT PARTS LIST

Notes: * Important safety notice:

 Components identified by \triangle mark have special characteristics important for safety.

Furthermore, special parts which have purposes of fire-retardant (resistors), high-quality sound (capacitors), low-noise (resistors), etc. are used.

When replacing any of components, be sure to use only manufacturer's specified parts shown in the parts list.

* The parenthesized indications in the Remarks columns specify the areas. (Refer to the cover page for area.)

Parts without these indications can be used for all areas.

Ref. No.	Part No.	Part Name & Description	Remarks	Ref. No.	Part No.	Part Name & Description	Remarks
		CABINET AND CHASSIS				INTEGRATED CIRCUIT(S)	
1	RHD30007-K1	SCREW		IC301	M5218AP	HEADPHONES AMP	
2	RKMD202A-K	CABINET		IC501	RSN3502	POWER AMP (MAIN)	\triangle
3	XTBS3+10JFZ1	SCREW		IC551	RSN3502	POWER AMP (SURROUND/CENTER)	\triangle
4	RWJ1808130XX	FLAT CABLE (8P) (W703)	(E, EB, EG, GN)	IC601	M5219FPTA	TONE AMP	
4	RWJ1808100XX	FLAT CABLE (8P) (W703)	(GC)	IC602	MC14066BFEL	SIGNAL SELECTOR	(GC)
5	RJS1A5508	CABLE HOLDER		IC801	BA6138	METER DRIVE AMP	
6	RMN0191	P. C. B. HOLDER		IC802	BA4558FDXT1	BUFFER AMP	
7	RFKJECA7-N	BOTTOM CHASSIS ASS'Y	(E, EB, EG, GN)	IC803	BU2090F-E2	LED DRIVE	
7	RFKJECH730GC	BOTTOM CHASSIS ASS'Y	(GC)			TRANSISTOR (S)	
7-1	RKA0011-3	FOOT					
8	RFKHECA10E-K	REAR GRILLE ASS'Y	(E, EG)	Q201, 202	2SD1450RTA	TRANSISTOR	
8	RFKHECA10EBK	REAR GRILLE ASS'Y	(EB, GN)	Q203	UN4115	TRANSISTOR	
8	RFKHECA10GCK	REAR GRILLE ASS'Y	(GC)	Q351	2SA1309AIRTA	TRANSISTOR	
9	SHE187-5	P. C. B SUPPORT		Q352	2SB621A-R	TRANSISTOR	
10	RMCO158	TRANSISTOR HOLDER		Q353	2SA1309AIRTA	TRANSISTOR	
11	RWJ1812220QC	FLAT CABLE (12P) (W501)		Q354	2SC3311AIRTA	TRANSISTOR	
12	RWJ1809220QC	FLAT CABLE (9P) (W502)		Q361	2SD2144S	TRANSISTOR	
13	RFKGECA10E-K	FRONT PANEL ASS'Y		Q362	2SA1309AIRTA	TRANSISTOR	
14	RGLO320-Q	PANEL LIGHT		Q371	2SA1309AIRTA	TRANSISTOR	
15	RGWO205-S	TONE CONTROL KNOB		Q551, 552	UN4115	TRANSISTOR	
16	RHD26016	SCREW		Q553, 554	2SD1450RTA	TRANSISTOR	
17	RMV0107	REFLECTION PLATE		Q571, 572	2SC3311AIRTA	TRANSISTOR	
18	RSE0007A	METER UNIT		Q573	2SA1309AIQTA	TRANSISTOR	
19	XTBS26+8J	SCREW		Q601, 602	2SC3312RSTA	TRANSISTOR	
20	XTBS3+8JFZ1	SCREW		Q606	UN4211	TRANSISTOR	(GC)
21	XTB3+10JFZ	SCREW		Q651, 652	2SD2144S	TRANSISTOR	
22	XTB3+12JFZ	SCREW	(E, EB, EG, GN)	Q701	2SD2374PQAU	TRANSISTOR	\triangle
23	XTB3+20JFZ	SCREW		Q702	2SB1548PQAU	TRANSISTOR	\triangle
24	XTB3+8JFZ	SCREW		Q704	2SC3311AIRTA	TRANSISTOR	
25	XTW3+15T	SCREW		Q751-754	2SD2137PQTA	TRANSISTOR	\triangle
26	RGU1357-1S	POWER BUTTON		Q755, 756	2SD1450RTA	TRANSISTOR	
27	REMO057	FAN MOTOR ASS'Y		Q757, 758	UN4111	TRANSISTOR	
28	RGU1358-K	SUB BUTTON		Q801	2SD1862QSTV6	TRANSISTOR	\triangle
29	RME0208	EARTH WIRE		Q802	UN4111	TRANSISTOR	
30	RMN0190-1	P. C. B. HOLDER	(GC)	Q803	UN4115	TRANSISTOR	
31	RMV0119	BARRIER	(GC)	Q804	UN4115TA	TRANSISTOR	(GC)
32	XTB3+12JFZ	SCREW	(GC)	Q805	UN4211	TRANSISTOR	
33	XTB3+8JFZ	SCREW	(GC)	Q809	UN4211	TRANSISTOR	
						DIODE (S)	
				D351	MA165	DIODE	
				D352	MA4100LTA	DIODE	

Ref. No.	Part No.	Part Name & Description	Remarks	Ref. No.	Part No.	Part Name & Description	Remarks
D361	MA4075MTA	DIODE		F701, 702	XBA2C16TB0	FUSE, 250V T1. 6A	△
D362	MA165	DIODE					
D371	MA700TA	DIODE				SWITCH(ES)	
D372	MA165	DIODE					
D501, 502	MA165	DIODE		S701	ESE37314	VOLTAGE ADJ.	(GC) △
D601, 602	MA4068HTA	DIODE	(GC) △	S801	EVQ21405R	POWER	
D701-704	1N5402BF	DIODE	△	S802	EVQ21405R	MODE	
D705, 706	RL1N4003N02	DIODE	△	S803	EVQ21405R	TEST	
D712	MA4240H	DIODE		S804	EVQ21405R	DELAY TIME	
D715, 716	MA4150M	DIODE	△	S805	EVQ21405R	CENTER MODE	
D717	MA4051MTA	DIODE	△			RELAY(S)	
D751-754	RL1N4003N02	DIODE	△				
D755	MA4082LTA	DIODE	△	RL701	RSY0013M-0	RELAY	△
D756	MA165	DIODE					
D761-764	RL1N4003N02	DIODE	△			CONNECTOR(S) AND SOCKET	
D781, 782	RL1N4003N02	DIODE	△				
D802	MA4100MTA	DIODE	△	CN601	RJU057W004	SOCKET (4P)	
D803-806	1SS254TA	DIODE		CN701-708	RJS1A1101T1	CONNECTOR (1P)	
D807	MA4100MTA	DIODE	△	CN709	RJS1A1101T1	CONNECTOR (1P)	(E, EB, EG, GN)
D831-834	1SS254TA	DIODE		CN710	RJS1A1101T1	CONNECTOR (1P)	(EB, GN)
D836	MA4051-L	DIODE		CN712	RJS1A1101T1	CONNECTOR (1P)	(E, EG)
D837	MA4056HTA	DIODE	△	CN715	RJU057W004	SOCKET (4P)	
D838, 839	1SS254TA	DIODE		CN501-1-3	RJS1A6604	CONNECTOR (4P)	
D841-844	SLR-305VC	L. E. D.		CN502-1-3	RJS1A6603	CONNECTOR (3P)	
D861, 862	MA700TA	DIODE		CN703-1, 2	RJS1A6604	CONNECTOR (4P)	
D863, 864	1SS254TA	DIODE		CP601	RJT057W004-1	CONNECTOR (4P)	
		VARIABLE RESISTOR(S)		CP715	RJT057W004-1	CONNECTOR (4P)	
				JK201	RJT065K20	CONNECTOR (20P)	
VR601, 602	EVJYV1F03G24	TREBLE/BASS CONTROL		JK351	SJT3213	CONNECTOR (2P)	
VR808, 809	EVNDXAA00B53	POWER METER ADJ.		JK702	SJS702-2	CONNECTOR (7P)	(GC)
		COIL(S)				JACK(S) AND TERMINAL(S)	
L501, 502	RLQYR73M	COIL		JK301	RJJ67TA02	HEADPHONES	
L551, 552	RLQYR73M	COIL		JK501	RJR0054	SPEAKER (MAIN)	
L701	RLQZ271M	COIL	(E, EB, EG, GN) △	JK502	RJH2301MS	SPEAKER (CENTER/SURROUND)	
		TRANSFORMER(S)		JK701	SJS9236	AC INLET	(E, EB, EG, GC) △
				JK701	SJSD16-1	AC INLET	(GN) △
						EARTH PLATE(S)	
PT701	RTP2N5B003	POWER TRANSFORMER	(E, EB, EG, GN) △				
PT701	RTP1V5E004-W	POWER TRANSFORMER	(GC) △	E501	SNE1004-2	EARTH PLATE	
		LAMP(S)		E701	SNE1004-2	EARTH PLATE	
						FUSE HOLDER(S)	
PL801-806	XAMR137	LAMP					
		FUSE(S)		FC1-6	EYF52BC	FUSE HOLDER	
				FC7, 8	EYF52BC	FUSE HOLDER	(GC)
F1	XBA2C16TB0	FUSE, 250V T1. 6A	(E, EB, EG, GN) △				
F1	XBA2C31TB0	FUSE, 250V T3. 15A	(GC) △				
F2	XBA2C16TB0	FUSE, 250V T1. 6A	(GC) △				

RESISTORS AND CAPACITORS

Notes: * Capacity values are in microfarads (μF) unless specified otherwise, P=Pico-farads (pF) F=Farads (F)
* Resistance values are in ohms, unless specified otherwise, 1K=1,000 (OHM), 1M=1,000k (OHM)

Ref. No.	Part No.	Values & Remarks	Ref. No.	Part No.	Values & Remarks	Ref. No.	Part No.	Values & Remarks
		RESISTORS	R561	ERDS2TJ151	1/4W 150	R717	ERDS2TJ473	1/4W 47K
			R562	ERDS2TJ471	1/4W 470	R731	ERDS2TJ104	1/4W 100K
			R563, 564	ERDS2TJ563	1/4W 56K	R752	ERDS2TJ822	1/4W 8.2K
R223, 224	ERDS2TJ332	1/4W 3.3K	R565, 566	ERD25FVJ100T	1/4W 10 Δ	R761-764	ERDS2TJ1R0	1/4W 1.0
R251	ERDS2TJ222	1/4W 2.2K	R567, 568	ERDS1FVJ100T	1/2W 10 Δ	R765	ERDS2TJ471	1/4W 470
R253, 254	ERDS2EJ121	1/4W 120	R569	ERDS2TJ823T	1/4W 82K	R766	ERDS2TJ563	1/4W 56K
R255	ERDS2TJ154	1/4W 150K	R570	ERDS2TJ124T	1/4W 120K	R777	ERX1SJ6R8E	1W 6.8
R256	ERDS2TJ105T	1/4W 1M	R571	ERDS2TJ823T	1/4W 82K	R778, 779	ERX1SJ5R6E	1W 5.6
R259	ERDS2TJ561	1/4W 560	R572	ERDS2TJ124T	1/4W 120K	R780	ERDS2TJ822	1/4W 8.2K
R291, 292	ERDS2TJ822	1/4W 8.2K	R573	ERDS2TJ563	1/4W 56K	R783	ERDS2TJ221	1/4W 220
R301, 302	ERDS2TJ222	1/4W 2.2K	R574	ERDS2TJ564	1/4W 560K	R791, 792	ERDS2TJ101	1/4W 100
R303, 304	ERDS2TJ333	1/4W 33K	R575	ERDS2TJ223	1/4W 22K	R801, 802	ERDS2TJ272T	1/4W 2.7K
R305, 306	ERDS2TJ223	1/4W 22K	R583, 584	ERDS2TJ154	1/4W 150K	R803, 804	ERDS2TJ104	1/4W 100K
R307, 308	ERDS2TJ222	1/4W 2.2K	R585, 586	ERDS2TJ105T	1/4W 1M	R805, 806	ERDS2TJ155	1/4W 1.5M
R309-312	ERDS2EJ121	1/4W 120	R587, 588	ERDS2EJ121	1/4W 120	R807, 808	ERDS2TJ331	1/4W 330
R351	ERDS2TJ183T	1/4W 18K	R589	ERDS2TJ561	1/4W 560	R811, 812	ERDS2TJ821	1/4W 820
R352	ERDS2TJ473	1/4W 47K	R590	ERDS2TJ334	1/4W 330K	R816	ERDS2TJ104	1/4W 100K
R353	ERDS2TJ223	1/4W 22K	R591	ERD2FCVG470T	1/4W 47 Δ	R817, 818	ERDS2TJ221	1/4W 220
R354	ERDS2TJ104	1/4W 100K	R601, 602	ERDS2TJ472	1/4W 4.7K	R819	ERDS2TJ104	1/4W 100K
R355	ERDS2TJ103	1/4W 10K	R603, 604	ERDS2TJ473	1/4W 47K	R821, 822	ERDS2TJ123	1/4W 12K
R357	ERGISJ100E	1W 10	R605, 606	ERDS2TJ123	1/4W 12K	R823, 824	ERDS2TJ154	1/4W 150K
R358	ERGISJ220E	1W 22	R607, 608	ERDS2TJ222	1/4W 2.2K	R825, 826	ERDS2TJ223	1/4W 22K
R359	ERDS2TJ273	1/4W 27K	R609, 610	ERDS2TJ821	1/4W 820	R827, 828	ERDS2TJ102	1/4W 1K
R360	ERDS2TJ152	1/4W 1.5K	R611, 612	ERDS2TJ122	1/4W 1.2K	R829	ERDS2TJ222	1/4W 2.2K
R361	ERDS2TJ104	1/4W 100K	R613, 614	ERDS2TJ683	1/4W 68K	R831	ERDS2TJ821	1/4W 820
R362	ERDS2TJ101	1/4W 100	R615, 616	ERDS2TJ123	1/4W 12K	R832	ERDS2TJ102	1/4W 1K
R363, 364	ERDS2TJ103	1/4W 10K	R625, 626	ERDS2TJ183T	1/4W 18K	R833	ERDS2TJ122	1/4W 1.2K
R365	ERDS2TJ335T	1/4W 3.3M	R627, 628	ERDS2TJ123	1/4W 12K	R834	ERDS2TJ152	1/4W 1.5K
R371	ERDS2TJ683	1/4W 68K	R631-634	ERDS2TJ104	1/4W 100K	R836, 837	ERDS2TJ472	1/4W 4.7K
R372	ERDS2TJ561	1/4W 560	R635, 636	ERDS2TJ100	1/4W 10 E, EB, EG, GN	R838	ERDS2TJ332	1/4W 3.3K
R373	ERDS2TJ101	1/4W 100	R635, 636	ERDS2TJ223	1/4W 22K GC	R841, 842	ERDS2TJ332	1/4W 3.3K
R374	ERDS2TJ472	1/4W 4.7K	R637, 638	ERDS2TJ472	1/4W 4.7K	R843	ERDS2TJ102	1/4W 1K
R375	ERDS2TJ103	1/4W 10K	R639, 640	ERDS2TJ100	1/4W 10 E, EB, EG, GN	R844	ERDS2TJ332	1/4W 3.3K GC
R391	ERDS2TJ473	1/4W 47K	R639, 640	ERDS2TJ223	1/4W 22K GC	R845, 846	ERDS2TJ102	1/4W 1K
R501, 502	ERDS2TJ102	1/4W 1K	R641	ERDS2TJ333	1/4W 33K GC	R847	ERDS2TJ221	1/4W 220
R503-506	ERDS2TJ563	1/4W 56K	R643, 644	ERDS2TJ332	1/4W 3.3K GC	R848	ERDS2TJ104	1/4W 100K
R507, 508	ERDS2TJ102	1/4W 1K	R651, 652	ERDS2TJ222	1/4W 2.2K	R849, 850	ERDS2TJ102	1/4W 1K
R509, 510	ERDS2TJ821	1/4W 820	R653, 654	ERDS2EJ121	1/4W 120	R851	ERDS2TJ331	1/4W 330
R511	ERDS2TJ334	1/4W 330K	R655	ERDS2TJ561	1/4W 560	R852	ERDS2TJ391	1/4W 390
R512	ERDS2TJ154	1/4W 150K	R657, 658	ERDS2TJ224T	1/4W 220K	R853	ERDS2TJ392T	1/4W 3.9K
R513	ERDS2TJ684	1/4W 680K	R701	ERD2FCVJ4R7T	1/4W 4.7 Δ	R855, 856	ERDS2TJ393	1/4W 39K
R514	ERD25FJ470	1/4W 47 Δ	R702	ERQ16NKW2R2E	1/6W 2.2 Δ	R857, 858	ERDS2TJ331	1/4W 330
R515, 516	ERDS1FVJ100T	1/2W 10 Δ	R703, 704	ERDS2TJ562	1/4W 5.6K	R861, 862	ERDS2TJ681	1/4W 680
R517, 518	ERD25FVJ100T	1/4W 10 Δ	R705	ERDS2TJ333	1/4W 33K	R863	ERDS2TJ222	1/4W 2.2K
R551, 552	ERDS2TJ222	1/4W 2.2K	R706	ERDS2TJ100	1/4W 10	R864, 865	ERDS2TJ221	1/4W 220
R553, 554	ERDS2TJ102	1/4W 1K	R709	ERGISJ331E	1W 330	R870	ERDS2TJ222	1/4W 2.2K
R555, 556	ERDS2TJ104	1/4W 100K	R711	ERGISJ391E	1W 390	R871, 872	ERDS2TJ272T	1/4W 2.7K
R557, 558	ERDS2TJ563	1/4W 56K	R713	ERX1SJ6R8E	1W 6.8	R879	ERDS2TJ221	1/4W 220
R559, 560	ERDS2TJ102	1/4W 1K	R716	ERDS2TJ392T	1/4W 3.9K	R885, 886	ERDS2EJ121	1/4W 120

Ref. No.	Part No.	Values & Remarks	Ref. No.	Part No.	Values & Remarks	Ref. No.	Part No.	Values & Remarks
R887, 888	ERDS2TJ152	1/4W 1.5K	C553, 554	RCE1HKA3R3BG	50V 3.3U	C710	ECBT1E103ZF	25V 0.01U
			C555, 556	ECBT1H331KB5	50V 330P	C711	ECQE1104KF3	100V 0.1U
		CAPACITORS	C557, 558	ECBT1C122KR5	16V 1200P	C712	ECBT1E223ZF	25V 0.022U
			C561, 562	ECBT1H150J5	50V 15P	C714	ECKR1H103ZF5	50V 0.01U
C251	RCEOJKA221BV	6.3V 220U	C563, 564	RCE1HKA4R7BG	50V 4.7U	C715	ECA1VHG471B	35V 470U
C301, 302	RCE1CKA100BG	16V 10U	C565, 566	ECFR1H104ZF	50V 0.1U	C731	ECEA1HKN010B	50V 1U
C303-306	ECBT1H101KB5	50V 100P	C567, 568	RCEOJKA470BG	6.3V 47U	C761	ECA1EM102B	25V 1000U Δ
C307, 308	RCE1CKA220BG	16V 22U	C569	ECA2AAP100B	100V 10U	C762	ECBT1E103ZF	25V 0.01U
C309, 310	RCE1HKA3R3BG	50V 3.3U	C571	RCEOJKA101BV	6.3V 100U	C781	ECA1EM101B	25V 100U Δ
C353	ECEA1HKA2R2B	50V 2.2U	C572	ECBT1E223ZF	25V 0.022U	C799	ECBT1H104ZF5	50V 0.1U
C361	ECEA1KA221B	10V 220U	C601, 602	RCE1HKA3R3BG	50V 3.3U	C801, 802	ECEA1EKN3R3B	25V 3.3U
C362, 363	RCE1CKA100BG	16V 10U	C603-606	ECBT1H101KB5	50V 100P	C803, 804	ECEA1HKA2R2B	50V 2.2U
C364	ECBT1E103ZF	25V 0.01U	C607, 608	ECBT1H151KB5	50V 150P	C805	RCE1HKA4R7BG	50V 4.7U
C371	RCEOJKA101BV	6.3V 100U	C609, 610	ECBT1E103ZF	25V 0.01U	C806	RCEOJKA221BV	6.3V 220U
C372	ECBT1E103ZF	25V 0.01U	C611, 612	RCE1HKA3R3BG	50V 3.3U	C808, 809	ECBT1E223ZF	25V 0.022U
C381, 382	ECBT1E103ZF	25V 0.01U	C613, 614	RCE1CKA100BG	16V 10U	C810	RCE1HKA4R7BG	50V 4.7U
C397, 398	ECBT1E103ZF	25V 0.01U	C615, 616	ECEA1HKA010B	50V 1U	C831	RCE1CKA100BG	16V 10U
C501, 502	ECA1HAP3R3B	50V 3.3U	C617, 618	ECQV1H823JM3	50V 0.082U	C832	ECBT1E103ZF	25V 0.01U
C503, 504	ECBT1C152KR5	16V 1500P	C623, 624	ECBT1E103ZF	25V 0.01U GC	C833	ECBT1H104ZF5	50V 0.1U
C505, 506	ECBT1H150J5	50V 15P	C626	ECBT1E103ZF	25V 0.01U GC	C834, 835	ECBT1H471KB5	50V 470P
C507, 508	ECBT1C682KR5	16V 6800P	C631, 632	RCE1HKA3R3BG	50V 3.3U	C836, 837	RCE1HKA3R3BG	50V 3.3U
C509, 510	RCE1CKA220BG	16V 22U	C633, 634	ECBT1C822KS5	16V 8200P	C855, 856	ECBT1C682KR5	16V 6800P
C511, 512	ECBT1C122KR5	16V 1200P	C653	RCE1CKA101BV	16V 100U	C905, 906	ECBT1H101KB5	50V 100P
C513	ECA1VM101B	35V 100U	C701, 702	ECES1H682VNG	50V 6800U Δ	C1101, 1102	ECBT1H473ZF5	50V 0.047U
C514	ECA2AAP100B	100V 10U	C703, 704	ECEA1CKA330B	16V 33U	C1103-1106	ECBT1H102KB5	50V 1000P
C515, 516	ECFR1H104ZF	50V 0.1U	C705, 706	ECKR1H103ZF5	50V 0.01U	C1107, 1108	ECBT1H473ZF5	50V 0.047U
C551, 552	ECBT1H101KB5	50V 100P	C707	ECA1HM470B	50V 47U Δ	C1109-1111	ECBT1H102KB5	50V 1000P

REPLACEMENT PARTS LIST

- Notes:**
- * Important safety notice:
Components identified by Δ mark have special characteristics important for safety.
Furthermore, special parts which have purposes of fire-retardant (resistors), high-quality sound (capacitors), low-noise (resistors), etc. are used.
When replacing any of components, be sure to use only manufacturer's specified parts shown in the parts list.
 - * The parenthesized indications in the Remarks columns specify the areas. (Refer to the cover page for area.)
Parts without these indications can be used for all areas.
 - * Remote Control Ass'y: Supply period for three years from termination of production.
 - * The "(SF)" mark denotes the standard part.

Ref. No.	Part No.	Part Name & Description	Remarks	Ref. No.	Part No.	Part Name & Description	Remarks
				P3	RPN0961	CUSHION (TUNER)	
		PACKING MATERIAL		P3	RPN0951	CUSHION (CD)	
				P3	RPN0950	CUSHION (DECK)	
P1	RPG2819	PACKING CASE (SYSTEM)	(E, EG)	P4	RPQ0164	PAD	
P1	RPG2776	PACKING CASE (SYSTEM)	(EB)	P5	RPF0134	PROTECTION BAG (F. B.)	
P1	RPG2820	PACKING CASE (SYSTEM)	(GC)	P6	SQZD3	AREA LABEL	(E)
P1	RPG2822	PACKING CASE (SYSTEM)	(GN)	P6	SQZD7	AREA LABEL	(EB)
P2	RPG2706	PACKING CASE (AMPLIFIER)		P6	SQZD6	AREA LABEL	(EG)
P2	RPG2708	PACKING CASE (TUNER)		P6	RQLA0066	AREA LABEL	(GC)
P2	RPG2777	PACKING CASE (CD)		P6	RQLA0067	AREA LABEL	(GN)
P2	RPG2707	PACKING CASE (DECK)		P7	RPQ0541	SPACER	
P3	RPN0949	CUSHION (AMPLIFIER)		P8	SPP740	PROTECTION BAG (UNIT)	

Ref. No.	Part No.	Part Name & Description	Remarks
		ACCESSORIES	
A1	RAK-CH744WH	REMOTE CONTROL TRANSMITTER	(E, EG)
A1	RAK-CH745WH	REMOTE CONTROL TRANSMITTER	(EB, GC, GN)
A1-1	RKK0020-K	BATTERY COVER FOR R. C. T.	
A2	REED393	SPEAKER CORDS	
A3	REX0608	FLAT CABLE (SHORT) (20P)	
A4	REX0660	FLAT CABLE (MIDDLE) (19P)	
A5	REX0661	FLAT CABLE (LONG) (15P)	
A6	RJA0019-2K	AC POWER SUPPLY CORD	(E, EG, GC) Δ (SF)
A6	RJA0049-K	AC POWER SUPPLY CORD	(EB) Δ
A6	RJA0036-K	AC POWER SUPPLY CORD	(GN) Δ
A7	RQA0117	WARRANTY CARD	(E, EB, EG)
A7	RQX7433ZA	WARRANTY CARD	(GN)
A8	RQC80169	SERVICENTER LIST	
A9	RFKSECA10E-K	INSTRUCTION MANUAL ASS'Y	(E)

Ref. No.	Part No.	Part Name & Description	Remarks
A9	RFKSECA10EBK	INSTRUCTION MANUAL ASS'Y	(EB)
A9	RQT3264-D	INSTRUCTION MANUAL	(EG)
A9	RQT3265-G	INSTRUCTION MANUAL	(GC)
A9	RQT3266-B	INSTRUCTION MANUAL	(GN)
A10	RSA0007	FM INDOOR ANTENNA	(E, EB, EG)
A10	RSA0006	FM INDOOR ANTENNA	(GC, GN)
A11	RSA0012	AM (LW/MW) LOOP ANTENNA	
A11-1	RMN0244	ANTENNA HOLDER	
A11-2	XTN3+12AFZ	MOUNTING SCREW	
A12	SJP9009	ATTACHMENT PLUG	(EB) Δ
A13	RQLA0134	VOLTAGE CAUTION LABEL	(GC)
A14	SJP5213-1	POWER PLUG ADAPTOR	(GC) Δ
		<GREASE OR JIG/TOOL>	
		GREASE	
SA1	RFKX0002	COMPOUND GREASE	

PACKAGING

Tuner: ST-CA10

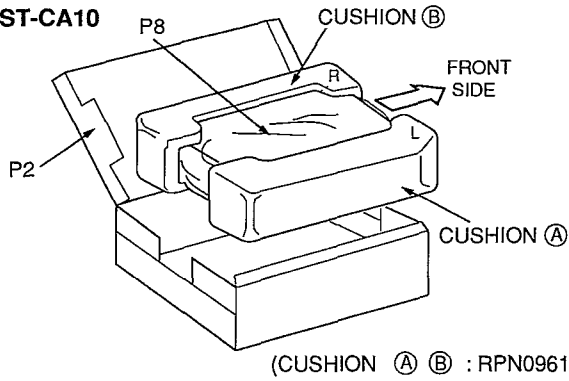

Cassette deck: RS-CA10

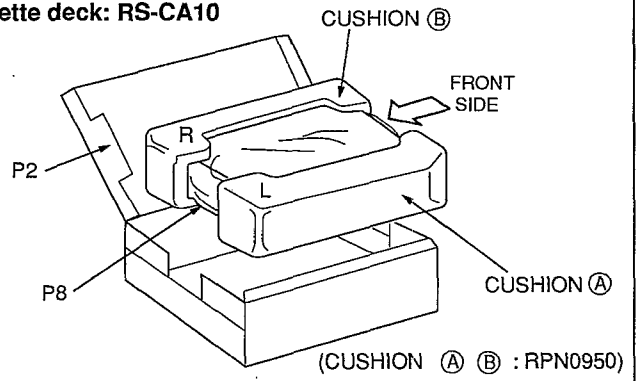

CD Changer: SL-CA10

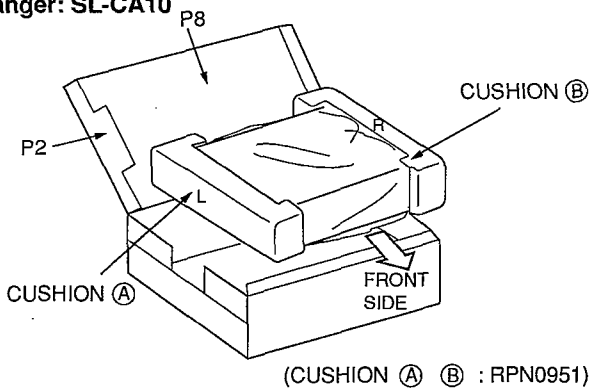

System: SC-CA10

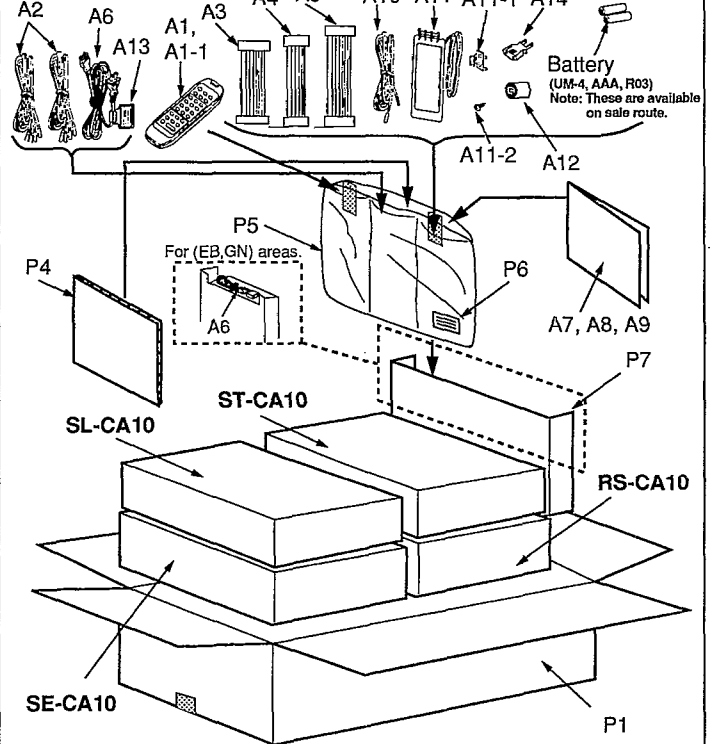

Amplifier: SE-CA10

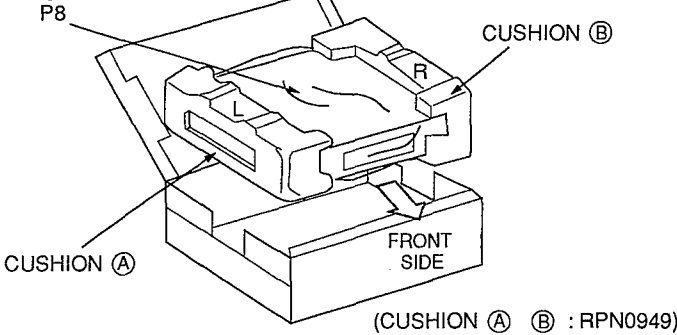

REPLACEMENT PARTS LIST

Notes: * Important safety notice:

 Components identified by \triangle mark have special characteristics important for safety.

Furthermore, special parts which have purposes of fire-retardant (resistors), high-quality sound (capacitors), low-noise (resistors), etc. are used.

When replacing any of components, be sure to use only manufacturer's specified parts shown in the parts list.

* The parenthesized indications in the Remarks columns specify the areas. (Refer to the cover page for area.)

Parts without these indications can be used for all areas.

Ref. No.	Part No.	Part Name & Description	Remarks	Ref. No.	Part No.	Part Name & Description	Remarks
		CABINET AND CHASSIS				INTEGRATED CIRCUIT(S)	
1	RHD30007-K1	SCREW		IC301	M5218AP	HEADPHONES AMP	
2	RKMD202A-K	CABINET		IC501	RSN3502	POWER AMP (MAIN)	\triangle
3	XTBS3+10JFZ1	SCREW		IC551	RSN3502	POWER AMP (SURROUND/CENTER)	\triangle
4	RWJ1808130XX	FLAT CABLE (8P) (W703)	(E, EB, EG, GN)	IC601	M5219FPTA	TONE AMP	
4	RWJ1808100XX	FLAT CABLE (8P) (W703)	(GC)	IC602	MC14066BFEL	SIGNAL SELECTOR	(GC)
5	RJS1A5508	CABLE HOLDER		IC801	BA6138	METER DRIVE AMP	
6	RMN0191	P. C. B. HOLDER		IC802	BA4558FDXT1	BUFFER AMP	
7	RFKJECA7-N	BOTTOM CHASSIS ASS'Y	(E, EB, EG, GN)	IC803	BU2090F-E2	LED DRIVE	
7	RFKJECH730GC	BOTTOM CHASSIS ASS'Y	(GC)			TRANSISTOR (S)	
7-1	RKA0011-3	FOOT					
8	RFKHECA10E-K	REAR GRILLE ASS'Y	(E, EG)	Q201, 202	2SD1450RTA	TRANSISTOR	
8	RFKHECA10EBK	REAR GRILLE ASS'Y	(EB, GN)	Q203	UN4115	TRANSISTOR	
8	RFKHECA10GCK	REAR GRILLE ASS'Y	(GC)	Q351	2SA1309AIRTA	TRANSISTOR	
9	SHE187-5	P. C. B SUPPORT		Q352	2SB621A-R	TRANSISTOR	
10	RMCO158	TRANSISTOR HOLDER		Q353	2SA1309AIRTA	TRANSISTOR	
11	RWJ1812220QC	FLAT CABLE (12P) (W501)		Q354	2SC3311AIRTA	TRANSISTOR	
12	RWJ1809220QC	FLAT CABLE (9P) (W502)		Q361	2SD2144S	TRANSISTOR	
13	RFKGECA10E-K	FRONT PANEL ASS'Y		Q362	2SA1309AIRTA	TRANSISTOR	
14	RGLO320-Q	PANEL LIGHT		Q371	2SA1309AIRTA	TRANSISTOR	
15	RGWO205-S	TONE CONTROL KNOB		Q551, 552	UN4115	TRANSISTOR	
16	RHD26016	SCREW		Q553, 554	2SD1450RTA	TRANSISTOR	
17	RMV0107	REFLECTION PLATE		Q571, 572	2SC3311AIRTA	TRANSISTOR	
18	RSE0007A	METER UNIT		Q573	2SA1309AIQTA	TRANSISTOR	
19	XTBS26+8J	SCREW		Q601, 602	2SC3312RSTA	TRANSISTOR	
20	XTBS3+8JFZ1	SCREW		Q606	UN4211	TRANSISTOR	(GC)
21	XTB3+10JFZ	SCREW		Q651, 652	2SD2144S	TRANSISTOR	
22	XTB3+12JFZ	SCREW	(E, EB, EG, GN)	Q701	2SD2374PQAU	TRANSISTOR	\triangle
23	XTB3+20JFZ	SCREW		Q702	2SB1548PQAU	TRANSISTOR	\triangle
24	XTB3+8JFZ	SCREW		Q704	2SC3311AIRTA	TRANSISTOR	
25	XTW3+15T	SCREW		Q751-754	2SD2137PQTA	TRANSISTOR	\triangle
26	RGU1357-1S	POWER BUTTON		Q755, 756	2SD1450RTA	TRANSISTOR	
27	REMO057	FAN MOTOR ASS'Y		Q757, 758	UN4111	TRANSISTOR	
28	RGU1358-K	SUB BUTTON		Q801	2SD1862QSTV6	TRANSISTOR	\triangle
29	RME0208	EARTH WIRE		Q802	UN4111	TRANSISTOR	
30	RMN0190-1	P. C. B. HOLDER	(GC)	Q803	UN4115	TRANSISTOR	
31	RMV0119	BARRIER	(GC)	Q804	UN4115TA	TRANSISTOR	(GC)
32	XTB3+12JFZ	SCREW	(GC)	Q805	UN4211	TRANSISTOR	
33	XTB3+8JFZ	SCREW	(GC)	Q809	UN4211	TRANSISTOR	
						DIODE (S)	
				D351	MA165	DIODE	
				D352	MA4100LTA	DIODE	

Ref. No.	Part No.	Part Name & Description	Remarks	Ref. No.	Part No.	Part Name & Description	Remarks
D361	MA4075MTA	DIODE		F701, 702	XBA2C16TB0	FUSE, 250V T1. 6A	△
D362	MA165	DIODE					
D371	MA700TA	DIODE				SWITCH(ES)	
D372	MA165	DIODE					
D501, 502	MA165	DIODE		S701	ESE37314	VOLTAGE ADJ.	(GC) △
D601, 602	MA4068HTA	DIODE	(GC) △	S801	EVQ21405R	POWER	
D701-704	1N5402BF	DIODE	△	S802	EVQ21405R	MODE	
D705, 706	RL1N4003N02	DIODE	△	S803	EVQ21405R	TEST	
D712	MA4240H	DIODE		S804	EVQ21405R	DELAY TIME	
D715, 716	MA4150M	DIODE	△	S805	EVQ21405R	CENTER MODE	
D717	MA4051MTA	DIODE	△			RELAY(S)	
D751-754	RL1N4003N02	DIODE	△				
D755	MA4082LTA	DIODE	△	RL701	RSY0013M-0	RELAY	△
D756	MA165	DIODE					
D761-764	RL1N4003N02	DIODE	△			CONNECTOR(S) AND SOCKET	
D781, 782	RL1N4003N02	DIODE	△				
D802	MA4100MTA	DIODE	△	CN601	RJU057W004	SOCKET (4P)	
D803-806	1SS254TA	DIODE		CN701-708	RJS1A1101T1	CONNECTOR (1P)	
D807	MA4100MTA	DIODE	△	CN709	RJS1A1101T1	CONNECTOR (1P)	(E, EB, EG, GN)
D831-834	1SS254TA	DIODE		CN710	RJS1A1101T1	CONNECTOR (1P)	(EB, GN)
D836	MA4051-L	DIODE		CN712	RJS1A1101T1	CONNECTOR (1P)	(E, EG)
D837	MA4056HTA	DIODE	△	CN715	RJU057W004	SOCKET (4P)	
D838, 839	1SS254TA	DIODE		CN501-1-3	RJS1A6604	CONNECTOR (4P)	
D841-844	SLR-305VC	L. E. D.		CN502-1-3	RJS1A6603	CONNECTOR (3P)	
D861, 862	MA700TA	DIODE		CN703-1, 2	RJS1A6604	CONNECTOR (4P)	
D863, 864	1SS254TA	DIODE		CP601	RJT057W004-1	CONNECTOR (4P)	
		VARIABLE RESISTOR(S)		CP715	RJT057W004-1	CONNECTOR (4P)	
				JK201	RJT065K20	CONNECTOR (20P)	
VR601, 602	EVJYV1F03G24	TREBLE/BASS CONTROL		JK351	SJT3213	CONNECTOR (2P)	
VR808, 809	EVNDXAA00B53	POWER METER ADJ.		JK702	SJS702-2	CONNECTOR (7P)	(GC)
		COIL(S)				JACK(S) AND TERMINAL(S)	
L501, 502	RLQYR73M	COIL		JK301	RJJ67TA02	HEADPHONES	
L551, 552	RLQYR73M	COIL		JK501	RJR0054	SPEAKER (MAIN)	
L701	RLQZ271M	COIL	(E, EB, EG, GN) △	JK502	RJH2301MS	SPEAKER (CENTER/SURROUND)	
		TRANSFORMER(S)		JK701	SJS9236	AC INLET	(E, EB, EG, GC) △
				JK701	SJSD16-1	AC INLET	(GN) △
						EARTH PLATE(S)	
PT701	RTP2N5B003	POWER TRANSFORMER	(E, EB, EG, GN) △				
PT701	RTP1V5E004-W	POWER TRANSFORMER	(GC) △	E501	SNE1004-2	EARTH PLATE	
		LAMP(S)		E701	SNE1004-2	EARTH PLATE	
						FUSE HOLDER(S)	
PL801-806	XAMR137	LAMP					
		FUSE(S)		FC1-6	EYF52BC	FUSE HOLDER	
				FC7, 8	EYF52BC	FUSE HOLDER	(GC)
F1	XBA2C16TB0	FUSE, 250V T1. 6A	(E, EB, EG, GN) △				
F1	XBA2C31TB0	FUSE, 250V T3. 15A	(GC) △				
F2	XBA2C16TB0	FUSE, 250V T1. 6A	(GC) △				

RESISTORS AND CAPACITORS

Notes: * Capacity values are in microfarads (μF) unless specified otherwise, P=Pico-farads (pF) F=Farads (F)
* Resistance values are in ohms, unless specified otherwise, 1K=1,000 (OHM), 1M=1,000k (OHM)

Ref. No.	Part No.	Values & Remarks	Ref. No.	Part No.	Values & Remarks	Ref. No.	Part No.	Values & Remarks
		RESISTORS	R561	ERDS2TJ151	1/4W 150	R717	ERDS2TJ473	1/4W 47K
			R562	ERDS2TJ471	1/4W 470	R731	ERDS2TJ104	1/4W 100K
			R563, 564	ERDS2TJ563	1/4W 56K	R752	ERDS2TJ822	1/4W 8.2K
R223, 224	ERDS2TJ332	1/4W 3.3K	R565, 566	ERD25FVJ100T	1/4W 10 Δ	R761-764	ERDS2TJ1R0	1/4W 1.0
R251	ERDS2TJ222	1/4W 2.2K	R567, 568	ERDS1FVJ100T	1/2W 10 Δ	R765	ERDS2TJ471	1/4W 470
R253, 254	ERDS2EJ121	1/4W 120	R569	ERDS2TJ823T	1/4W 82K	R766	ERDS2TJ563	1/4W 56K
R255	ERDS2TJ154	1/4W 150K	R570	ERDS2TJ124T	1/4W 120K	R777	ERX1SJ6R8E	1W 6.8
R256	ERDS2TJ105T	1/4W 1M	R571	ERDS2TJ823T	1/4W 82K	R778, 779	ERX1SJ5R6E	1W 5.6
R259	ERDS2TJ561	1/4W 560	R572	ERDS2TJ124T	1/4W 120K	R780	ERDS2TJ822	1/4W 8.2K
R291, 292	ERDS2TJ822	1/4W 8.2K	R573	ERDS2TJ563	1/4W 56K	R783	ERDS2TJ221	1/4W 220
R301, 302	ERDS2TJ222	1/4W 2.2K	R574	ERDS2TJ564	1/4W 560K	R791, 792	ERDS2TJ101	1/4W 100
R303, 304	ERDS2TJ333	1/4W 33K	R575	ERDS2TJ223	1/4W 22K	R801, 802	ERDS2TJ272T	1/4W 2.7K
R305, 306	ERDS2TJ223	1/4W 22K	R583, 584	ERDS2TJ154	1/4W 150K	R803, 804	ERDS2TJ104	1/4W 100K
R307, 308	ERDS2TJ222	1/4W 2.2K	R585, 586	ERDS2TJ105T	1/4W 1M	R805, 806	ERDS2TJ155	1/4W 1.5M
R309-312	ERDS2EJ121	1/4W 120	R587, 588	ERDS2EJ121	1/4W 120	R807, 808	ERDS2TJ331	1/4W 330
R351	ERDS2TJ183T	1/4W 18K	R589	ERDS2TJ561	1/4W 560	R811, 812	ERDS2TJ821	1/4W 820
R352	ERDS2TJ473	1/4W 47K	R590	ERDS2TJ334	1/4W 330K	R816	ERDS2TJ104	1/4W 100K
R353	ERDS2TJ223	1/4W 22K	R591	ERD2FCVG470T	1/4W 47 Δ	R817, 818	ERDS2TJ221	1/4W 220
R354	ERDS2TJ104	1/4W 100K	R601, 602	ERDS2TJ472	1/4W 4.7K	R819	ERDS2TJ104	1/4W 100K
R355	ERDS2TJ103	1/4W 10K	R603, 604	ERDS2TJ473	1/4W 47K	R821, 822	ERDS2TJ123	1/4W 12K
R357	ERGISJ100E	1W 10	R605, 606	ERDS2TJ123	1/4W 12K	R823, 824	ERDS2TJ154	1/4W 150K
R358	ERGISJ220E	1W 22	R607, 608	ERDS2TJ222	1/4W 2.2K	R825, 826	ERDS2TJ223	1/4W 22K
R359	ERDS2TJ273	1/4W 27K	R609, 610	ERDS2TJ821	1/4W 820	R827, 828	ERDS2TJ102	1/4W 1K
R360	ERDS2TJ152	1/4W 1.5K	R611, 612	ERDS2TJ122	1/4W 1.2K	R829	ERDS2TJ222	1/4W 2.2K
R361	ERDS2TJ104	1/4W 100K	R613, 614	ERDS2TJ683	1/4W 68K	R831	ERDS2TJ821	1/4W 820
R362	ERDS2TJ101	1/4W 100	R615, 616	ERDS2TJ123	1/4W 12K	R832	ERDS2TJ102	1/4W 1K
R363, 364	ERDS2TJ103	1/4W 10K	R625, 626	ERDS2TJ183T	1/4W 18K	R833	ERDS2TJ122	1/4W 1.2K
R365	ERDS2TJ335T	1/4W 3.3M	R627, 628	ERDS2TJ123	1/4W 12K	R834	ERDS2TJ152	1/4W 1.5K
R371	ERDS2TJ683	1/4W 68K	R631-634	ERDS2TJ104	1/4W 100K	R836, 837	ERDS2TJ472	1/4W 4.7K
R372	ERDS2TJ561	1/4W 560	R635, 636	ERDS2TJ100	1/4W 10 E, EB, EG, GN	R838	ERDS2TJ332	1/4W 3.3K
R373	ERDS2TJ101	1/4W 100	R635, 636	ERDS2TJ223	1/4W 22K GC	R841, 842	ERDS2TJ332	1/4W 3.3K
R374	ERDS2TJ472	1/4W 4.7K	R637, 638	ERDS2TJ472	1/4W 4.7K	R843	ERDS2TJ102	1/4W 1K
R375	ERDS2TJ103	1/4W 10K	R639, 640	ERDS2TJ100	1/4W 10 E, EB, EG, GN	R844	ERDS2TJ332	1/4W 3.3K GC
R391	ERDS2TJ473	1/4W 47K	R639, 640	ERDS2TJ223	1/4W 22K GC	R845, 846	ERDS2TJ102	1/4W 1K
R501, 502	ERDS2TJ102	1/4W 1K	R641	ERDS2TJ333	1/4W 33K GC	R847	ERDS2TJ221	1/4W 220
R503-506	ERDS2TJ563	1/4W 56K	R643, 644	ERDS2TJ332	1/4W 3.3K GC	R848	ERDS2TJ104	1/4W 100K
R507, 508	ERDS2TJ102	1/4W 1K	R651, 652	ERDS2TJ222	1/4W 2.2K	R849, 850	ERDS2TJ102	1/4W 1K
R509, 510	ERDS2TJ821	1/4W 820	R653, 654	ERDS2EJ121	1/4W 120	R851	ERDS2TJ331	1/4W 330
R511	ERDS2TJ334	1/4W 330K	R655	ERDS2TJ561	1/4W 560	R852	ERDS2TJ391	1/4W 390
R512	ERDS2TJ154	1/4W 150K	R657, 658	ERDS2TJ224T	1/4W 220K	R853	ERDS2TJ392T	1/4W 3.9K
R513	ERDS2TJ684	1/4W 680K	R701	ERD2FCVJ4R7T	1/4W 4.7 Δ	R855, 856	ERDS2TJ393	1/4W 39K
R514	ERD25FJ470	1/4W 47 Δ	R702	ERQ16NKW2R2E	1/6W 2.2 Δ	R857, 858	ERDS2TJ331	1/4W 330
R515, 516	ERDS1FVJ100T	1/2W 10 Δ	R703, 704	ERDS2TJ562	1/4W 5.6K	R861, 862	ERDS2TJ681	1/4W 680
R517, 518	ERD25FVJ100T	1/4W 10 Δ	R705	ERDS2TJ333	1/4W 33K	R863	ERDS2TJ222	1/4W 2.2K
R551, 552	ERDS2TJ222	1/4W 2.2K	R706	ERDS2TJ100	1/4W 10	R864, 865	ERDS2TJ221	1/4W 220
R553, 554	ERDS2TJ102	1/4W 1K	R709	ERGISJ331E	1W 330	R870	ERDS2TJ222	1/4W 2.2K
R555, 556	ERDS2TJ104	1/4W 100K	R711	ERGISJ391E	1W 390	R871, 872	ERDS2TJ272T	1/4W 2.7K
R557, 558	ERDS2TJ563	1/4W 56K	R713	ERX1SJ6R8E	1W 6.8	R879	ERDS2TJ221	1/4W 220
R559, 560	ERDS2TJ102	1/4W 1K	R716	ERDS2TJ392T	1/4W 3.9K	R885, 886	ERDS2EJ121	1/4W 120

Ref. No.	Part No.	Values & Remarks	Ref. No.	Part No.	Values & Remarks	Ref. No.	Part No.	Values & Remarks
R887, 888	ERDS2TJ152	1/4W 1.5K	C553, 554	RCE1HKA3R3BG	50V 3.3U	C710	ECBT1E103ZF	25V 0.01U
			C555, 556	ECBT1H331KB5	50V 330P	C711	ECQE1104KF3	100V 0.1U
		CAPACITORS	C557, 558	ECBT1C122KR5	16V 1200P	C712	ECBT1E223ZF	25V 0.022U
			C561, 562	ECBT1H150J5	50V 15P	C714	ECKR1H103ZF5	50V 0.01U
C251	RCEOJKA221BV	6.3V 220U	C563, 564	RCE1HKA4R7BG	50V 4.7U	C715	ECA1VHG471B	35V 470U
C301, 302	RCE1CKA100BG	16V 10U	C565, 566	ECFR1H104ZF	50V 0.1U	C731	ECEA1HKN010B	50V 1U
C303-306	ECBT1H101KB5	50V 100P	C567, 568	RCEOJKA470BG	6.3V 47U	C761	ECA1EM102B	25V 1000U Δ
C307, 308	RCE1CKA220BG	16V 22U	C569	ECA2AAP100B	100V 10U	C762	ECBT1E103ZF	25V 0.01U
C309, 310	RCE1HKA3R3BG	50V 3.3U	C571	RCEOJKA101BV	6.3V 100U	C781	ECA1EM101B	25V 100U Δ
C353	ECEA1HKA2R2B	50V 2.2U	C572	ECBT1E223ZF	25V 0.022U	C799	ECBT1H104ZF5	50V 0.1U
C361	ECEA1KA221B	10V 220U	C601, 602	RCE1HKA3R3BG	50V 3.3U	C801, 802	ECEA1EKN3R3B	25V 3.3U
C362, 363	RCE1CKA100BG	16V 10U	C603-606	ECBT1H101KB5	50V 100P	C803, 804	ECEA1HKA2R2B	50V 2.2U
C364	ECBT1E103ZF	25V 0.01U	C607, 608	ECBT1H151KB5	50V 150P	C805	RCE1HKA4R7BG	50V 4.7U
C371	RCEOJKA101BV	6.3V 100U	C609, 610	ECBT1E103ZF	25V 0.01U	C806	RCEOJKA221BV	6.3V 220U
C372	ECBT1E103ZF	25V 0.01U	C611, 612	RCE1HKA3R3BG	50V 3.3U	C808, 809	ECBT1E223ZF	25V 0.022U
C381, 382	ECBT1E103ZF	25V 0.01U	C613, 614	RCE1CKA100BG	16V 10U	C810	RCE1HKA4R7BG	50V 4.7U
C397, 398	ECBT1E103ZF	25V 0.01U	C615, 616	ECEA1HKA010B	50V 1U	C831	RCE1CKA100BG	16V 10U
C501, 502	ECA1HAP3R3B	50V 3.3U	C617, 618	ECQV1H823JM3	50V 0.082U	C832	ECBT1E103ZF	25V 0.01U
C503, 504	ECBT1C152KR5	16V 1500P	C623, 624	ECBT1E103ZF	25V 0.01U GC	C833	ECBT1H104ZF5	50V 0.1U
C505, 506	ECBT1H150J5	50V 15P	C626	ECBT1E103ZF	25V 0.01U GC	C834, 835	ECBT1H471KB5	50V 470P
C507, 508	ECBT1C682KR5	16V 6800P	C631, 632	RCE1HKA3R3BG	50V 3.3U	C836, 837	RCE1HKA3R3BG	50V 3.3U
C509, 510	RCE1CKA220BG	16V 22U	C633, 634	ECBT1C822KS5	16V 8200P	C855, 856	ECBT1C682KR5	16V 6800P
C511, 512	ECBT1C122KR5	16V 1200P	C653	RCE1CKA101BV	16V 100U	C905, 906	ECBT1H101KB5	50V 100P
C513	ECA1VM101B	35V 100U	C701, 702	ECES1H682VNG	50V 6800U Δ	C1101, 1102	ECBT1H473ZF5	50V 0.047U
C514	ECA2AAP100B	100V 10U	C703, 704	ECEA1CKA330B	16V 33U	C1103-1106	ECBT1H102KB5	50V 1000P
C515, 516	ECFR1H104ZF	50V 0.1U	C705, 706	ECKR1H103ZF5	50V 0.01U	C1107, 1108	ECBT1H473ZF5	50V 0.047U
C551, 552	ECBT1H101KB5	50V 100P	C707	ECA1HM470B	50V 47U Δ	C1109-1111	ECBT1H102KB5	50V 1000P

REPLACEMENT PARTS LIST

- Notes:**
- * Important safety notice:
Components identified by Δ mark have special characteristics important for safety.
Furthermore, special parts which have purposes of fire-retardant (resistors), high-quality sound (capacitors), low-noise (resistors), etc. are used.
When replacing any of components, be sure to use only manufacturer's specified parts shown in the parts list.
 - * The parenthesized indications in the Remarks columns specify the areas. (Refer to the cover page for area.)
Parts without these indications can be used for all areas.
 - * Remote Control Ass'y: Supply period for three years from termination of production.
 - * The "(SF)" mark denotes the standard part.

Ref. No.	Part No.	Part Name & Description	Remarks	Ref. No.	Part No.	Part Name & Description	Remarks
				P3	RPN0961	CUSHION (TUNER)	
		PACKING MATERIAL		P3	RPN0951	CUSHION (CD)	
				P3	RPN0950	CUSHION (DECK)	
P1	RPG2819	PACKING CASE (SYSTEM)	(E, EG)	P4	RPQ0164	PAD	
P1	RPG2776	PACKING CASE (SYSTEM)	(EB)	P5	RPF0134	PROTECTION BAG (F. B.)	
P1	RPG2820	PACKING CASE (SYSTEM)	(GC)	P6	SQZD3	AREA LABEL	(E)
P1	RPG2822	PACKING CASE (SYSTEM)	(GN)	P6	SQZD7	AREA LABEL	(EB)
P2	RPG2706	PACKING CASE (AMPLIFIER)		P6	SQZD6	AREA LABEL	(EG)
P2	RPG2708	PACKING CASE (TUNER)		P6	RQLA0066	AREA LABEL	(GC)
P2	RPG2777	PACKING CASE (CD)		P6	RQLA0067	AREA LABEL	(GN)
P2	RPG2707	PACKING CASE (DECK)		P7	RPQ0541	SPACER	
P3	RPN0949	CUSHION (AMPLIFIER)		P8	SPP740	PROTECTION BAG (UNIT)	

Ref. No.	Part No.	Part Name & Description	Remarks
		ACCESSORIES	
A1	RAK-CH744WH	REMOTE CONTROL TRANSMITTER	(E, EG)
A1	RAK-CH745WH	REMOTE CONTROL TRANSMITTER	(EB, GC, GN)
A1-1	RKK0020-K	BATTERY COVER FOR R. C. T.	
A2	REED393	SPEAKER CORDS	
A3	REX0608	FLAT CABLE (SHORT) (20P)	
A4	REX0660	FLAT CABLE (MIDDLE) (19P)	
A5	REX0661	FLAT CABLE (LONG) (15P)	
A6	RJA0019-2K	AC POWER SUPPLY CORD	(E, EG, GC) Δ (SF)
A6	RJA0049-K	AC POWER SUPPLY CORD	(EB) Δ
A6	RJA0036-K	AC POWER SUPPLY CORD	(GN) Δ
A7	RQA0117	WARRANTY CARD	(E, EB, EG)
A7	RQX7433ZA	WARRANTY CARD	(GN)
A8	RQC80169	SERVICENTER LIST	
A9	RFKSECA10E-K	INSTRUCTION MANUAL ASS'Y	(E)

Ref. No.	Part No.	Part Name & Description	Remarks
A9	RFKSECA10EBK	INSTRUCTION MANUAL ASS'Y	(EB)
A9	RQT3264-D	INSTRUCTION MANUAL	(EG)
A9	RQT3265-G	INSTRUCTION MANUAL	(GC)
A9	RQT3266-B	INSTRUCTION MANUAL	(GN)
A10	RSA0007	FM INDOOR ANTENNA	(E, EB, EG)
A10	RSA0006	FM INDOOR ANTENNA	(GC, GN)
A11	RSA0012	AM (LW/MW) LOOP ANTENNA	
A11-1	RMN0244	ANTENNA HOLDER	
A11-2	XTN3+12AFZ	MOUNTING SCREW	
A12	SJP9009	ATTACHMENT PLUG	(EB) Δ
A13	RQLA0134	VOLTAGE CAUTION LABEL	(GC)
A14	SJP5213-1	POWER PLUG ADAPTOR	(GC) Δ
		<GREASE OR JIG/TOOL>	
		GREASE	
SA1	RFKX0002	COMPOUND GREASE	

PACKAGING

