

NINTENDO AMPLIFIER

Now your playing with power (Power Stage)

R1,6,11 = 3 x 0.22 ohm 2W MPC74
 R2,5,7,9,12,14,16,18,20,25 = 10 x 10K 0.6W 0.1%
 R3,4,8,10,13,15,17,19 = 8 x 1k 0.6W 0.1%
 R21,24 = 2 x 2K2 0.6W 0.1%
 R22,23 = 2 x 200 0.25W 0.1%
 R26 = 1 x 10 5Watt
 R27 = 1 x 2.7 ohm 2W
 R28 = 1 x 470 ohm 0.6W 0.1%

C1,2,15,16,23,24,25,26,29,33,37 = 11 x 100n 100V WIMA RM5 MKS2
 C3,4,9,10,17,18,31,35 = 8 x 10uF 50V rad RM2.5
 C8,14,22,28,32 = 5 x 100uF 50V rad RM3.75 8x12mm
 C5,6,11,12,19,20 = 6 x 470uF 50V rad RM5 10x30mm
 C27 = 1 x 47p WIMA 1000V FKP2 RM5
 C30,34 = 2 x 1uF WIMA 50V MKS2
 C36 = 1 x 4.7uF WIMA 50V MKS2 RM5
 C38 = 1 x 680p WIMA 1000V FKP2 RM5
 C39 = 1 x 330p WIMA 100V FKP2 RM5

U1,2,3 = 6 x LM3886TF
 U4 = LM49710
 U5 = LM317
 U6 = LM337

D1,2,3 = 3 x Zener 16V 0.5W
 L1 = 1 x 0.7uH 18W 10mm Dia 1mm CuM
 Socket = 1 x 8 pin DIP8

* With 10K gain is 10x to get 20x gain use 20K resistor
 # Place parts when needed

Use two of this and balanced input board
 for 6 x LM3886 balanced amp

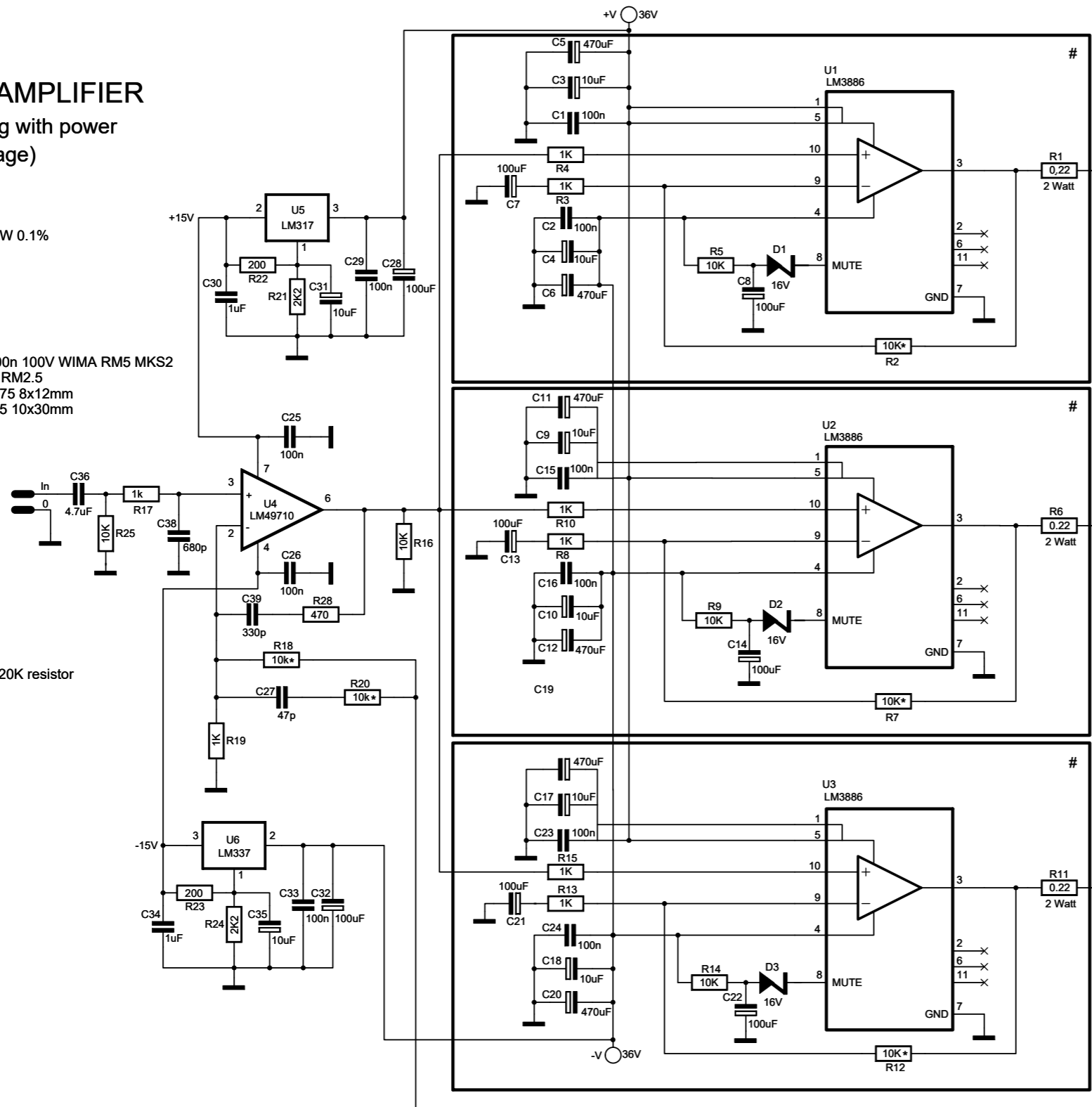

1 Channel (Un)Balanced 400W Poweramp

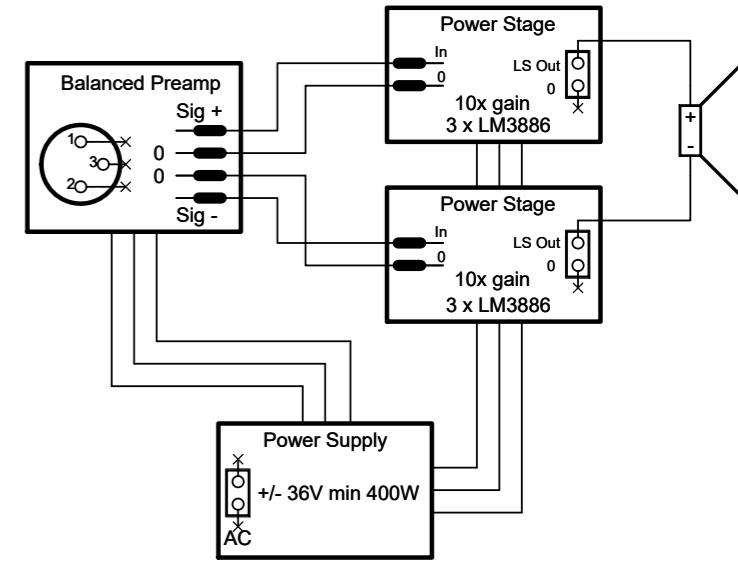

2 Channel Unbalanced 2 x 120W Poweramp

