

# TOA **PROFESSIONAL POWER AMP**

Model P-75D, P-150D, P-300D

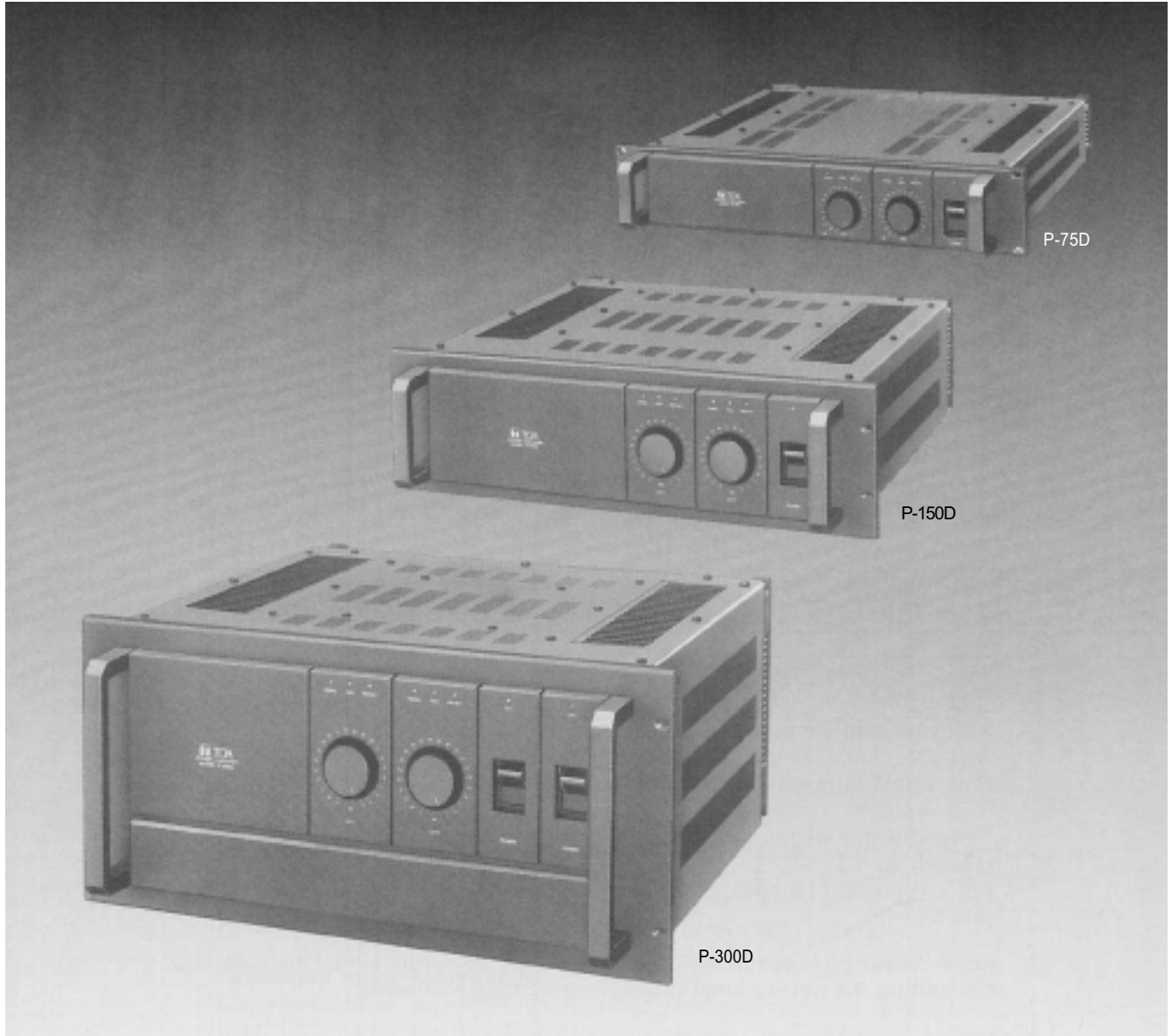

## Contents

Precautions .....	1
General Description .....	2
Features .....	2~ 3
Specifications .....	4~ 6
Performance Graphs .....	7~12
Front Panel .....	13~14
Rear Panel .....	15~16
Input/Output Connections .....	17~22
Installation Precautions .....	23~26
Appearance .....	27

## Precautions

1. XLR type audio connectors are factory wired as follows.  
Pins 1 and 2 are ground (shield); pin 3 is hot (high, plus).  
  
The connector wiring changes with use of an optional matching transformer.  
(Model No. PU-101T)  
Pin 1 is ground (shield), Pin 2 is cold (low, minus), and pin 3 is hot (high, plus).
2. Care should be taken in making connections, selecting signal sources and controlling the output level to avoid any damage to loads.
3. Never parallel the two amplifier outputs together.
4. Do not operate the amplifier from power mains which exceeds the indicated mains voltage by more than 10%.
5. Never connect the output of the amplifier to any other power source.
6. Do not expose the amplifier to corrosive chemicals or liquids such as, soft drinks, salt water, etc.
7. Always refer the amplifier to qualified technical service personnel. There are no user servicable parts inside.

## General Description

The P-75D, P-150D and P-300D are Toa professional 2-channel (stereo) power amplifiers, with nominal power outputs of 75 watts, 150 watts and 300 watts, respectively per channel with both channels driven into 8 ohms. Into 4 ohms they deliver 100 watts, 220 watts and 480 watts. In BTL (Bridged) mono use, the P-75D, P-150D and P-300D deliver 200 watts, 440 watts and 960 watts of power into 8 ohms. All models have frequency response of +0dB, -0.5dB (20Hz to 20kHz), total harmonic distortion of less than 0.1% (at each nominal power outputs, 8 ohms, 20Hz to 20kHz).

Each model offers many unique features such as, an octal socket for optional matching transformer to convert unbalanced input to balanced, magnetic circuit breaker, calibrated input attenuator, short circuit protection circuitry, 3-second turn-on delay, current limiter circuitry, protection indicator LED's, signal presence indicator LED's, peak indicator LED's, ground terminal strip, high pass filter, mono/stereo mode switch, and true dual-mono configuration. Protection indicator LED's are designed to actuate in cases of short circuit, D.C drift, turn-on delay and thermal warning. The signal presence indicator LED's glow when more than -30dB signal level is fed to the inputs.

For ease of maintenance and service, each channel of these amplifiers is built with modular, plug-in boards on a sub-chassis that can be quickly removed and replaced or repaired.

All models are mechanically reinforced by a rugged front panel made of 3mm (1/8") thick cast-aluminum and lined with another 3mm (1/8") thick steel. With their overall sturdy construction, they are capable of withstanding even the roughest use on the road.

## Features

### 1. Magnetic Circuit Breaker Power Switch

Both the primary mains (A.C. line) overload protection and the on/off switch are combined into a rocker-actuated, magnetic circuit breaker, whose operation, unlike fuses, is predictable and independent of temperature. Returning the switch to the "on" position resets the system.

### 2. Calibrated Input Attenuators

22-step detented input attenuators are provided for easy, accurate input sensitivity adjustment. The attenuators are in 2dB steps from 0dB attenuation to -34dB, then steps of -37dB, -42dB, -50dB, infinity. This arrangement provides a smooth, noise free transition from the highest to the lowest audio level.

### 3. Short-Circuit Protection Circuitry

Speaker protection is provided with relay circuitry that disconnects the load whenever a short-circuit or harmful D.C. current is present across the output terminals.

### 4. 3-Second Turn-On Delay

To help eliminate annoying clicks or pops which can occur upon turn-on in large sound systems, a three second mute/delay circuit is incorporated. The mute/delay circuit actuates the relay, and then disconnects the speakers the instant the circuit breaker is shut off.

**5. Current Limiter Circuitry**

Protection against shorted and low impedance loads is provided with dependable current limiting as well as protection against overloaded power supplies and input overload.

**6. Protection Indicator LED's (Including Thermal Warning)**

The LED's illuminate when the protection relay is activated in the following situations.

- 1) Short-circuit
- 2) D.C. drift
- 3) Turn-on delay

The LED's also flash when either of two heat sinks reaches more than 105°C in temperature.

**7. Signal Presence Indicator LED's**

The LEDs glow when more than -30dB level signal is fed to the inputs regardless of the input attenuator setting and output power level. They are helpful to assure that sufficient input signal is fed to drive the amplifiers.

**8. Peak Indicator LED's**

The LED's actuate by means of an input/output comparator, and glow when the output signal is clipped.

**9. Ground Terminal Strip**

Provision for isolating chassis ground from signal ground is provided on the rear panel.

**10. High Pass Filter Switch**

A switchable 15Hz high pass filter (12dB/octave) is provided to prevent damage from subsonic frequencies.

**11. Heavy aluminum Die-Cast Panel**

The power amplifiers are constructed to withstand even the roughest use on the road. Their aluminum die-cast front panels are mountable in standard 19-inch rack. A pair of sturdy carrying handles provide protection for the front panel controls and easy handling.

**12. Mono/Stereo Mode Switch**

An external slide switch provides quick and easy conversion for determining the power amplifiers' operating configuration as a single or dual channel amplifier.

**13. Two Regulated AC Supplies (applicable to P-300D)**

The P-300D is designed in a true dual-mono configuration. There are two completely separate amplifiers sharing only a common chassis and AC cord. Even the circuit breaker AC switches are separate.

The P-150 and P-75D are designed in dual-mono configuration, but share one power transformer and circuit breaker AC switch.

# Specifications (P-75D)

## Power Output

75 watts minimum sine wave continuous average power output per channel with both channel driving 8-ohm loads over a power band from 20Hz to 20kHz. The maximum Total Harmonic Distortion (THD) at any power level from 250 milliwatts to 75 watts shall be no more than 0.1%.

100 watts minimum sine wave continuous average power output per channel with both channel driving 4-ohm loads over a power band from 20Hz to 20kHz. The maximum Total Harmonic Distortion (THD) at any power level from 250 milliwatts to 100 watts shall be no more than 0.15%.

80 watts continuous average sine wave power into 8 ohms with less than 0.1% THD, at 1 kHz, both channels driven.

## Frequency Response

+0dB, -0.5dB, 20Hz to 20kHz

## Total Harmonic Distortion

Less than 0.005% at 75 watts, 8-ohm, 1kHz

Less than 0.1% at 75 watts, 8-ohm, 20Hz to 20kHz

## Intermodulation Distortion

0.05% using frequencies of 60Hz and 7kHz, mixed in a ratio of 4:1, at power output of 25 watts into 8-ohm

## Input Sensitivity

An input of +4dB (1.23V),  $\pm 0.5$ dB, produces an output of 75 watts into 8-ohm, INPUT ATTENUATOR set for maximum level

## Input Impedance

10k-ohm (unbalanced)

## Damping Factor

Greater than 150 at any frequency from 20Hz to 1kHz

Greater than 50 at any frequency from 20Hz to 20kHz

## Impedance Actual Output

Less than 0.06 ohms at any frequency from 20Hz to 1kHz

Less than 0.15 ohms at any frequency from 20Hz to 20kHz

## Hum and Noise

109dB below rated output (20Hz — 20kHz)

114dB below rated output (IHF-A weighted)

## Rise Time

10 microseconds, or better (10% -90% of 1 volt at 1kHz square wave output)

## Slew Rate

10 volts per microsecond, or better (at 25 watts into 8-ohm, 200kHz square wave input)

## Channel Separation

At least 95dB at 1kHz

At least 85dB at 20kHz

## Phase Shift

20Hz to 20kHz,  $\pm 15$  degrees

## Offset Voltage

Less than  $\pm 10$ mV DC

## Input Connectors (per channel)

One "male" and one "female" XLR connector in parallel, 2 "cold", pin 3 "hot", and pin 1 "shield". XLR's are unbalanced and in parallel with two tip-sleeve (standard) phone jack.

## Accessory Socket

8-pin octal socket accepts an optional matching transformer module for balanced input, or user options (pins include  $\pm VCC$ , signal input/output and circuit ground)

## Output Connectors (per channel)

Barrier Strip Terminal

## Ground Terminal Strip

2 lug terminal block with removal shorting strap

## Indicators

A pair of green LED's for signal presence

A pair of red LED's for output clipping

A pair of red LED's for circuit protection and thermal warning

A green LED for power ON

## Controls

### Input Attenuators

22-position, log-linear, detented and dB-calibrated input attenuators (one per channel) attenuates input signal in 2dB steps from 0dB attenuation to -34dB, then steps of -37dB, -42dB, -50dB, infinity.

### Circuit Breaker AC Switch

### High Pass Filter Switches (IN/OUT)

-12dB per octave at 15Hz

### Accessory Switches (IN/OUT)

Bypass for octal socket

### Mode Switch

Switchable for stereo/mono mode operation

## Overall Protection

AC line is protected by circuit breaker.

Protection LED's flashes when heat sink temperature reaches more than 105°C.

Protection LED's turn on when the protection relay activates in such cases that DC current is fed to output, and that short-circuit occurs.

## Turn On/Turn Off

No turn off transient. Three second delay turn On with minimum thumps and no dangerous transients

## AC Line Voltage

AC mains. 50Hz/60Hz

## Dimensions (W×H×D)

## Power Consumption

483 × 89 × 475 (mm)

400 watts maximum

19 × 3-1/2 × 18-3/4 (inches)

## Finish

Black painting

## Weight

13kg (29 lbs)

## MONAURAL MODE SPECIFICATIONS (P-75D)

### Power Output

150 watts minimum sine wave continuous average power output monaural driving 16-ohm loads over a power band from 20Hz to 20kHz. The maximum Total Harmonic Distortion (THD) at any power level from 250 milliwatts to 150 watts shall be no more than 0.1%.

200 watts minimum sine wave continuous average power output monaural driving 8-ohm loads over a power band from 20Hz to 20kHz. The maximum Total Harmonic Distortion (THD) at any power level from 250 milliwatts to 200 watts shall be no more than 0.15%.

210 watts continuous average sine wave power into 8-ohm with less than 0.1% THD at 1kHz

### Frequency Response

+0dB, -0.5dB, 20Hz to 20kHz

### Total Harmonic Distortion

Less than 0.05% at 200 watts into 8-ohm at 1kHz

### Intermodulation Distortion

0.05% using frequencies of 60Hz and 7kHz, mixed in a ratio of 4:1, at power output of 50 watts into 8-ohm

### Damping Factor (at 16-ohm)

Greater than 100 at any frequency from 20Hz to 1kHz

Greater than 30 at any frequency from 20Hz to 20kHz

### Impedance Actual Output

Less than 0.15-ohm at any frequency from 20Hz to 1kHz

Less than 0.3-ohm at any frequency from 20Hz to 20kHz

### Hum and Noise

112dB below rated output (20Hz to 20kHz)

116dB below rated output (IHF-A weighted)

**Note: 0dB is referenced to 0.775 volts RMS.**

# Specifications (P-150D)

## Power Output

150 watts minimum sine wave continuous average power output per channel with both channel driving 8-ohm loads over a power band from 20Hz to 20kHz. The maximum Total Harmonic Distortion (THD) at any power level from 250 milliwatts to 150 watts shall be no more than 0.1%.

220 watts minimum sine wave continuous average power output per channel with both channel driving 4-ohm loads over a power band from 20Hz to 20kHz. The maximum Total Harmonic Distortion (THD) at any power level from 250 milliwatts to 220 watts shall be no more than 0.15%.

160 watts continuous average sine wave power into 8 ohms with less than 0.1% THD, at 1 kHz, both channels driven.

## Frequency Response

+0dB, -0.5dB, 20Hz to 20kHz

## Total Harmonic Distortion

Less than 0.001% at 150 watts, 8-ohm, 1kHz

Less than 0.1% at 150 watts, 8-ohm, 20Hz to 20kHz

## Intermodulation Distortion

0.05% using frequencies of 60Hz and 7kHz, mixed in a ratio of 4:1, at power output of 50 watts into 8-ohm

## Input Sensitivity

An input of +4dB (1.23V),  $\pm 0.5$ dB, produces an output of 150 watts into 8-ohm, INPUT ATTENUATOR set for maximum level

## Input Impedance

10k-ohm (unbalanced)

## Damping Factor

Greater than 150 at any frequency from 20Hz to 1kHz

Greater than 70 at any frequency from 20Hz to 20kHz

## Impedance Actual Output

Less than 0.06 ohms at any frequency from 20Hz to 1kHz

Less than 0.12 ohms at any frequency from 20Hz to 20kHz

## Hum and Noise

110dB below rated output (20Hz — 20kHz) 115dB below rated output (IHF-A weighted)

## Rise Time

10 microseconds, or better (10% -90% of 1 volt at 1kHz square wave output)

## Slew Rate

10 volts per microsecond, or better (at 50 watts into 8-ohm, 200kHz square wave input)

## Channel Separation

At least 95dB at 1kHz

At least 75dB at 20kHz

## Phase Shift

20Hz to 20kHz,  $\pm 15$  degrees

## Offset Voltage

Less than  $\pm 10$ mV DC

## Input Connectors (per channel)

One "male" and one "female" XLR connector in parallel, 2 "cold", pin 3 "hot", and pin 1 "shield". XLR's are unbalanced and in parallel with two tip-sleeve (standard) phone jack.

Accessory Socket

8-pin octal socket accepts an optional matching transformer module for balanced input, or user options (pins include  $\pm$ VCC, signal input/output and circuit ground)

## Output Connectors (per channel)

Barrier Strip Terminal

## Ground Terminal Strip

2 lug terminal block with removal shorting strap

## Indicators

A pair of green LED's for signal presence

A pair of red LED's for output clipping

A pair of red LED's for circuit protection and thermal warning

A green LED for power ON

## Controls

Input Attenuators 22-position, log-linear, detented and dB-calibrated input attenuators (one per channel) attenuates input signal in 2dB steps from 0dB attenuation to -34dB, then steps of -37dB, -42dB, -50dB, infinity.

Circuit Breaker AC Switch

High Pass Filter Switches (IN/OUT)  
-12dB per octave at 15Hz

Accessory Switches (IN/OUT)  
Bypass for octal socket

Mode Switch

Switchable for stereo/mono mode operation

## Overall Protection

AC line is protected by circuit breaker.

Protection LED's flashes when heat sink temperature reaches more than 105°C.

Protection LED's turn on when the protection relay activates in such cases that DC current is fed to output, and that short-circuit occurs.

## Turn On/Turn Off

No turn off transient. Three second delay turn On with minimum thumps and no dangerous transients

## AC Line Voltage

AC mains. 50Hz/60Hz

## Dimensions (W×H×D)

Power Consumption 483 × 133 × 475 (mm)

800 watts maximum 19 × 5-1/4 × 18-3/4 (inches)

## Finish

Black painting

## Weight

20kg (44 lbs)

## MONAURAL MODE SPECIFICATIONS (P-150D)

### Power Output

300 watts minimum sine wave continuous average power output monaural driving 16-ohm loads over a power band from 20Hz to 20kHz. The maximum Total Harmonic Distortion (THD) at any power level from 250 milliwatts to 300 watts shall be no more than 0.1%.

440 watts minimum sine wave continuous average power output monaural driving 8-ohm loads over a power band from 20Hz to 20kHz. The maximum Total Harmonic Distortion (THD) at any power level from 250 milliwatts to 440 watts shall be no more than 0.15%.

500 watts continuous average sine wave power into 8-ohm with less than 0.1% THD at 1kHz

### Frequency Response

+0dB, -0.5dB, 20Hz to 20kHz

### Total Harmonic Distortion

Less than 0.01% at 440 watts into 8-ohm at 1kHz

### Intermodulation Distortion

0.05% using frequencies of 60Hz and 7kHz, mixed in a ratio of 4:1, at power output of 100 watts into 8-ohm

### Damping Factor (at 16-ohm)

Greater than 100 at any frequency from 20Hz to 1kHz

Greater than 70 at any frequency from 20Hz to 20kHz

### Impedance Actual Output

Less than 0.16-ohm at any frequency from 20Hz to 1kHz

Less than 0.2-ohm at any frequency from 20Hz to 20kHz

### Hum and Noise

110dB below rated output (20Hz to 20kHz)

115dB below rated output (IHF-A weighted)

**Note: 0dB is referenced to 0.775 volts RMS.**

# Specifications (P-300D)

## Power Output

300 watts minimum sine wave continuous average power output per channel with both channel driving 8-ohm loads over a power band from 20Hz to 20kHz. The maximum Total Harmonic Distortion (THD) at any power level from 250 milliwatts to 300 watts shall be no more than 0.1%.

480 watts minimum sine wave continuous average power output per channel with both channel driving 4-ohm loads over a power band from 20Hz to 20kHz. The maximum Total Harmonic Distortion (THD) at any power level from 250 milliwatts to 480 watts shall be no more than 0.15%.

320 watts continuous average sine wave power into 8 ohms with less than 0.1% THD, at 1 kHz, both channels driven.

## Frequency Response

+0dB, -0.5dB, 20Hz to 20kHz

## Total Harmonic Distortion

Less than 0.01% at 300 watts, 8-ohm, 1kHz

Less than 0.1% at 300 watts, 8-ohm, 20Hz to 20kHz

## Intermodulation Distortion

0.05% using frequencies of 60Hz and 7kHz, mixed in a ratio of 4:1, at power output of 100 watts into 8-ohm

## Input Sensitivity

An input of +4dB (1.23V),  $\pm 0.5$ dB, produces an output of 300 watts into 8-ohm, INPUT ATTENUATOR set for maximum level

## Input Impedance

10k-ohm (unbalanced)

## Damping Factor

Greater than 260 at any frequency from 20Hz to 1kHz

Greater than 95 at any frequency from 20Hz to 20kHz

## Impedance Actual Output

Less than 0.03 ohms at any frequency from 20Hz to 1kHz

Less than 0.08 ohms at any frequency from 20Hz to 20kHz

## Hum and Noise

109dB below rated output (20Hz — 20kHz)

114dB below rated output (IHF-A weighted)

## Rise Time

10 microseconds, or better (10% -90% of 1 volt at 1kHz square wave output)

## Slew Rate

10 volts per microsecond, or better (at 100 watts into 8-ohm, 200kHz square wave input)

## Channel Separation

At least 90dB at 1kHz

At least 75dB at 20kHz

## Phase Shift

20Hz to 20kHz,  $\pm 15$  degrees

## Offset Voltage

Less than  $\pm 10$ mV DC

## Input Connectors (per channel)

One "male" and one "female" XLR connector in parallel, 2 "cold", pin 3 "hot", and pin 1 "shield". XLR's are unbalanced and in parallel with two tip-sleeve (standard) phone jack.

## Accessory Socket

8-pin octal socket accepts an optional matching transformer module for balanced input, or user options (pins include  $\pm VCC$ , signal input/output and circuit ground)

## Output Connectors (per channel)

Standard 3/4-inch spacing, "5-way" binding posts

## Ground Terminal Strip

2 lug terminal block with removal shorting strap

## Indicators

A pair of green LED's for signal presence

A pair of red LED's for output clipping

A pair of red LED's for circuit protection and thermal warning

A green LED for power ON

## Controls

### Input Attenuators

22-position, log-linear, detented and dB-calibrated input attenuators (one per channel) attenuates input signal in 2dB steps from 0dB attenuation to -34dB, then steps of -37dB, -42dB, -50dB, infinity.

### Circuit Breaker AC Switch

### High Pass Filter Switches (IN/OUT)

-12dB per octave at 15Hz

### Accessory Switches (IN/OUT)

Bypass for octal socket

### Mode Switch

Switchable for stereo/mono mode operation

## Overall Protection

AC line is protected by circuit breaker.

Protection LED's flashes when heat sink temperature reaches more than 105°C.

Protection LED's turn on when the protection relay activates in such cases that DC current is fed to output, and that short-circuit occurs.

## Turn On/Turn Off

No turn off transient. Three second delay turn On with minimum thumps and no dangerous transients

## AC Line Voltage

AC mains. 50Hz/60Hz

## Power Consumption

1.7k watts maximum

## Finish

Black painting

## Dimensions (W×H×D)

483 × 222 × 475 (mm)

19 × 8-3/4 × 18-3/4 (inches)

## Weight

35kg (77 lbs)

## MONAURAL MODE SPECIFICATIONS (P-300D)

### Power Output

600 watts minimum sine wave continuous average power output monaural driving 16-ohm loads over a power band from 20Hz to 20kHz. The maximum Total Harmonic Distortion (THD) at any power level from 250 milliwatts to 600 watts shall be no more than 0.1%.

960 watts minimum sine wave continuous average power output monaural driving 8-ohm loads over a power band from 20Hz to 20kHz. The maximum Total Harmonic Distortion (THD) at any power level from 250 milliwatts to 960 watts shall be no more than 0.15%.

1100 watts continuous average sine wave power into 8-ohm with less than 0.1% THD at 1kHz

### Frequency Response

+0dB, -0.5dB, 20Hz to 20kHz

### Total Harmonic Distortion

Less than 0.005% at 960 watts into 8-ohm at 1kHz

### Intermodulation Distortion

0.05% using frequencies of 60Hz and 7kHz, mixed in a ratio of 4:1, at power output of 200 watts into 8-ohm

### Damping Factor (at 16-ohm)

Greater than 160 at any frequency from 20Hz to 1kHz

Greater than 50 at any frequency from 20Hz to 20kHz

### Impedance Actual Output

Less than 0.1-ohm at any frequency from 20Hz to 1kHz

Less than 0.3-ohm at any frequency from 20Hz to 20kHz

### Hum and Noise

109dB below rated output (20Hz to 20kHz)

114dB below rated output (IHF-A weighted)

**Note: 0dB is referenced to 0.775 volts RMS.**

# Performance Graphs (P-75D)

**POWER BANDWIDTH  
(BOTH CHANNELS DRIVEN)**

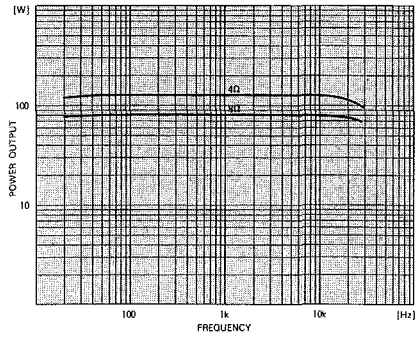

**LOAD IMPEDANCE vs POWER OUTPUT**

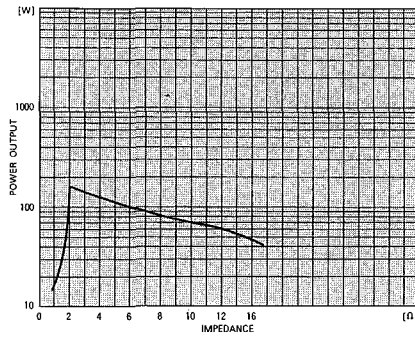

**FREQUENCY RESPONSE  
(BOTH CHANNEL DRIVEN)**

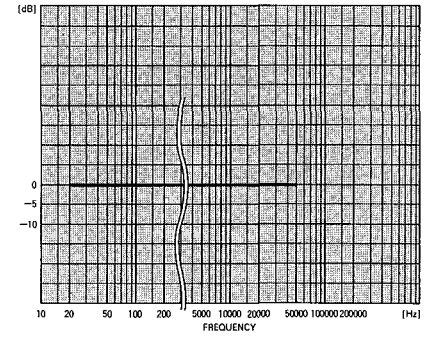

**T.H.D. vs FREQUENCY  
(BOTH CHANNEL DRIVEN)**

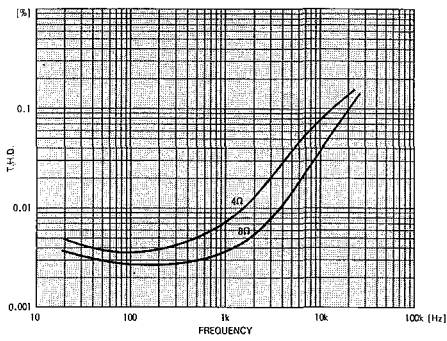

**T.H.D. vs POWER OUTPUT  
(BOTH CHANNELS DRIVEN)**

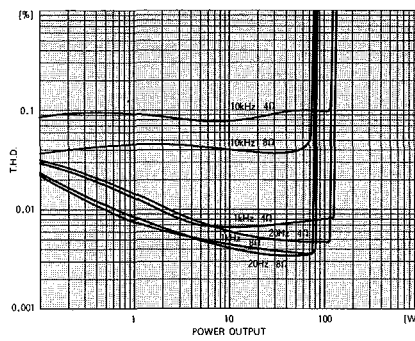

**INTERMODULATION DISTORTION  
VS POWER OUTPUT (ONE CHANNEL DRIVEN)  
MEASURED WITH A 4 : 1 MIX AT 60 Hz and 7 kHz**

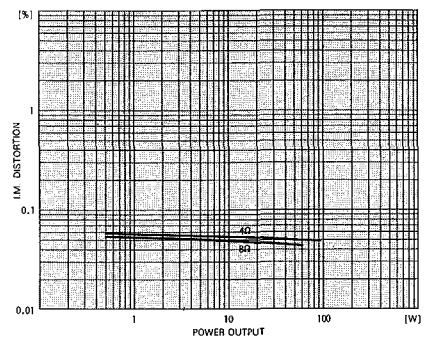

**DAMPING FACTOR vs FREQUENCY  
AT 8Ω LOAD IMPEDANCE**

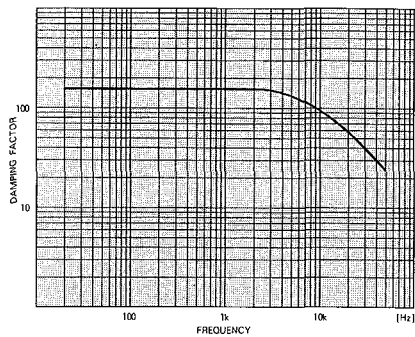

**ACTUAL OUTPUT IMPEDANCE  
vs FREQUENCY**

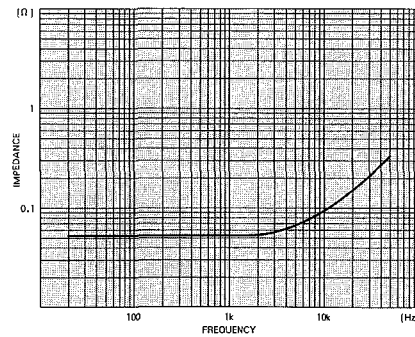

**CROSSTALK  
(BOTH INPUT ATTENUATORS  
AT MAXIMUM LEVEL)**

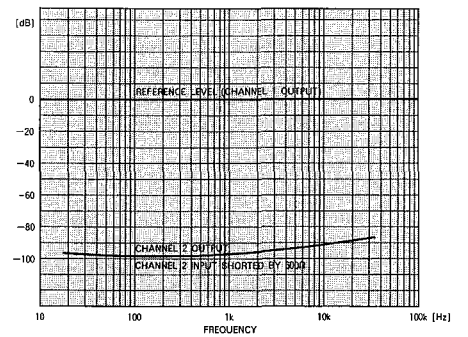

# Performance Graphs (P-75D)

**PHASE RESPONSE**

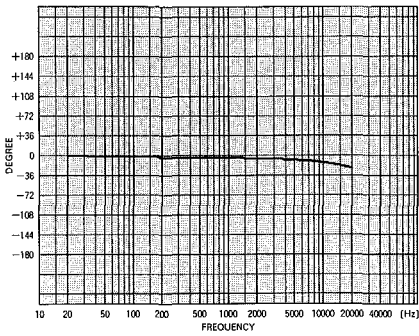

**POWER CONSUMPTION (BOTH CHANNEL DRIVEN)**

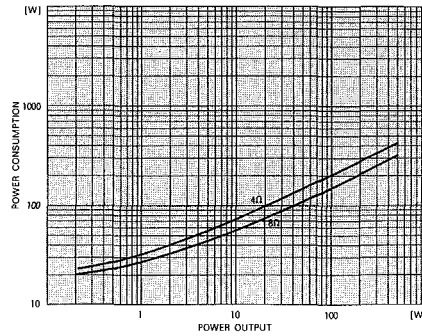

**POWER EFFICIENCY (BOTH CHANNEL DRIVEN)**

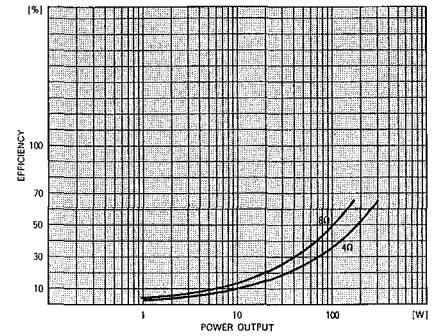

**POWER BANDWIDTH (MONO MODE)**

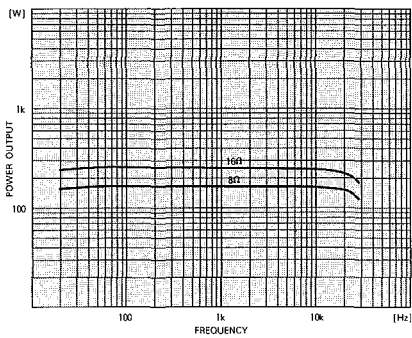

**LOAD IMPEDANCE vs POWER OUTPUT (MONO MODE)**

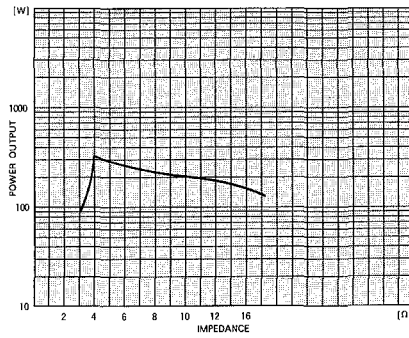

**FREQUENCY RESPONSE (MONO MODE)**

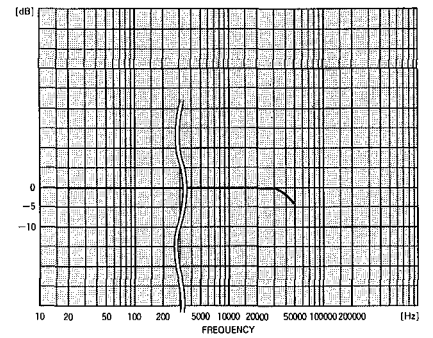

**T.H.D. vs FREQUENCY (MONO MODE)**

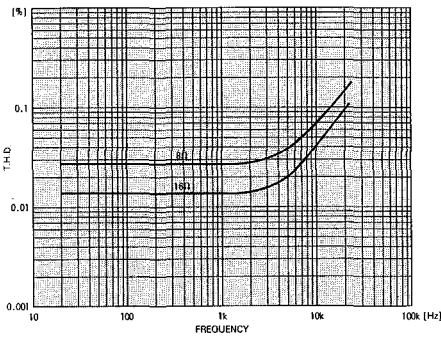

**T.H.D. vs POWER OUTPUT (MONO MODE)**

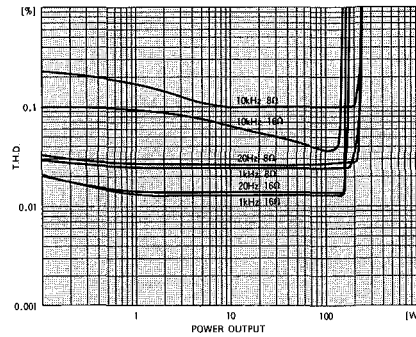

**POWER CONSUMPTION (MONO MODE)**

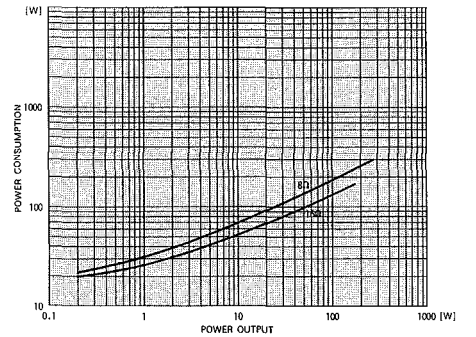

# Performance Graphs (P-150D)

**POWER BANDWIDTH (BOTH CHANNEL DRIVEN)**

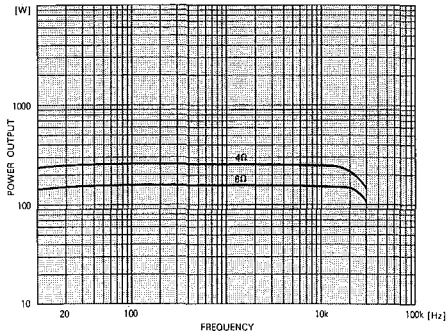

**LOAD IMPEDANCE vs POWER OUTPUT**

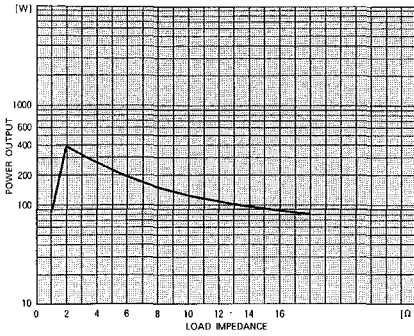

**FREQUENCY RESPONSE (BOTH CHANNEL DRIVEN)**

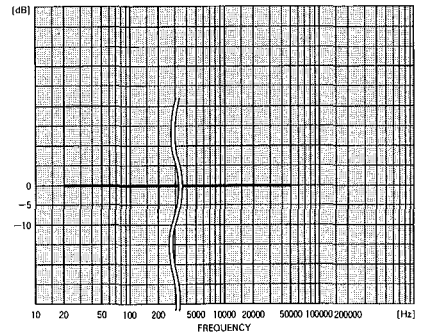

**T.H.D. vs FREQUENCY (BOTH CHANNEL DRIVEN)**

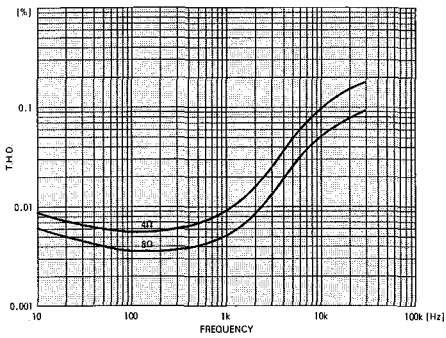

**T.H.D. vs POWER OUTPUT (BOTH CHANNELS DRIVEN)**

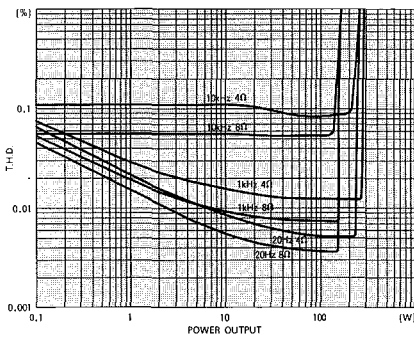

**INTERMODULATION DISTORTION VS POWER OUTPUT (ONE CHANNEL DRIVEN) MEASURED WITH A 4 : 1 MIX AT 60 Hz and 7 kHz**

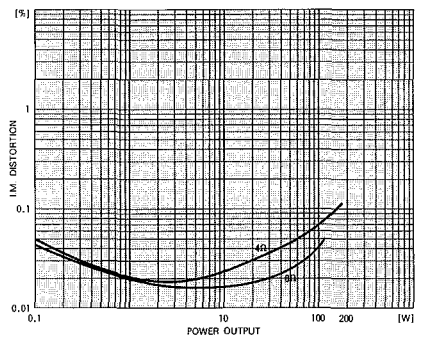

**DAMPING FACTOR vs FREQUENCY AT 8Ω LOAD IMPEDANCE**

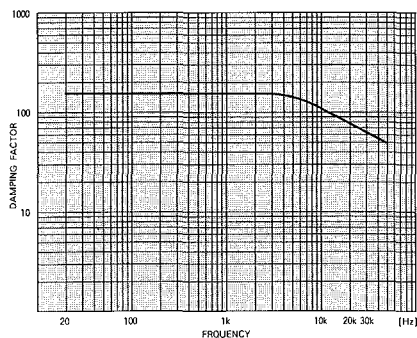

**ACTUAL OUTPUT IMPEDANCE vs FREQUENCY**

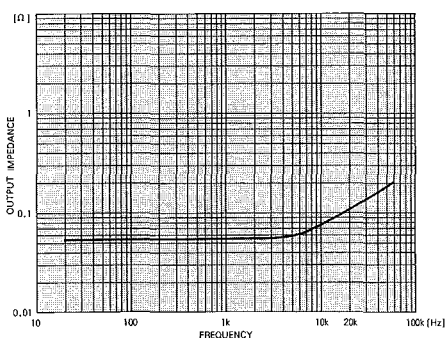

**CROSSTALK (BOTH INPUT ATTENUATORS AT MAXIMUM LEVEL)**

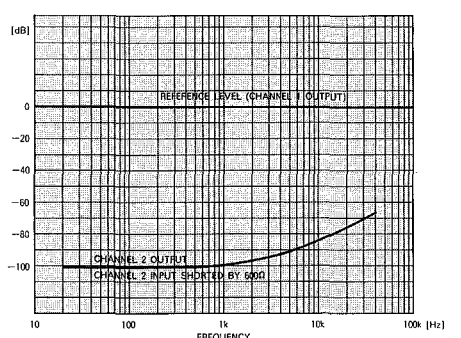

# Performance Graphs (P-150D)

**PHASE RESPONSE**

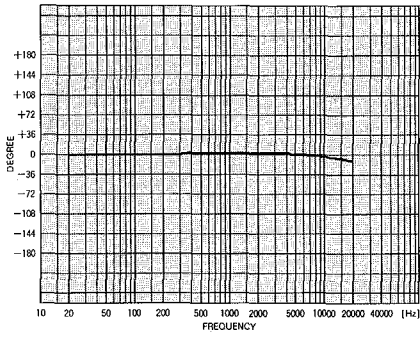

**POWER CONSUMPTION (BOTH CHANNEL DRIVEN)**

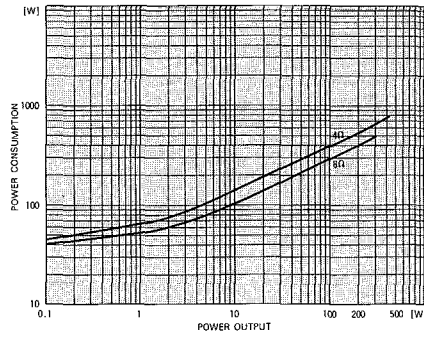

**POWER EFFICIENCY (BOTH CHANNEL DRIVEN)**

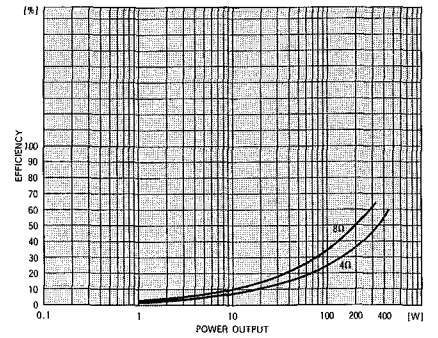

**POWER BANDWIDTH (MONO MODE)**

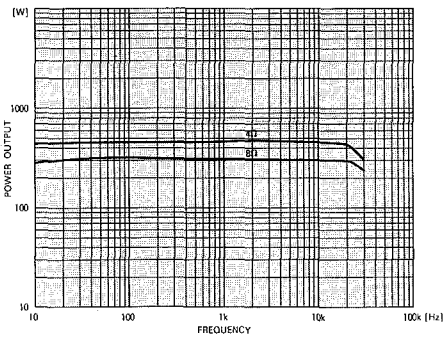

**LOAD IMPEDANCE vs POWER OUTPUT (MONO MODE)**

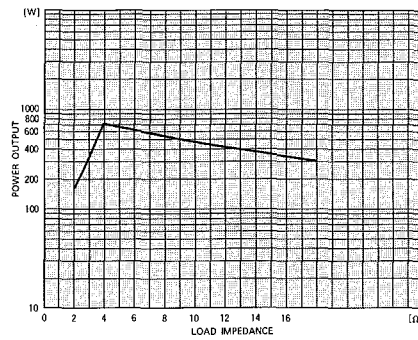

**FREQUENCY RESPONSE (MONO MODE)**

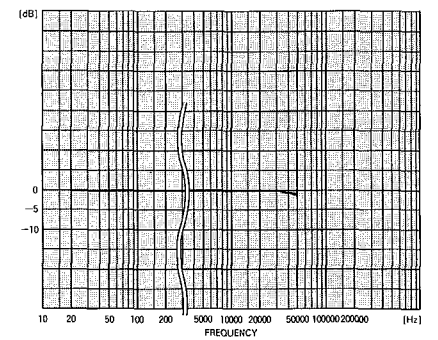

**T.H.D. vs FREQUENCY (MONO MODE)**

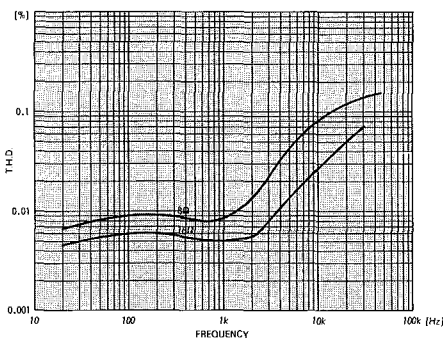

**T.H.D. vs POWER OUTPUT (MONO MODE)**

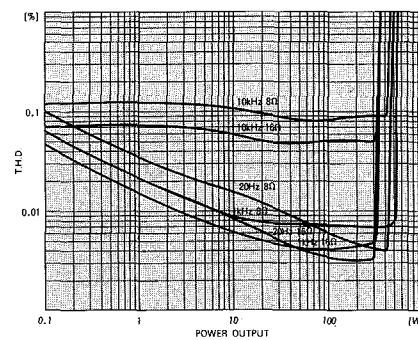

**POWER CONSUMPTION (MONO MODE)**

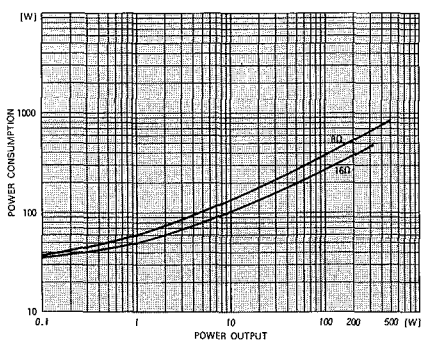

# Performance Graphs (P-300D)

**POWER BANDWIDTH  
(BOTH CHANNEL DRIVEN)**

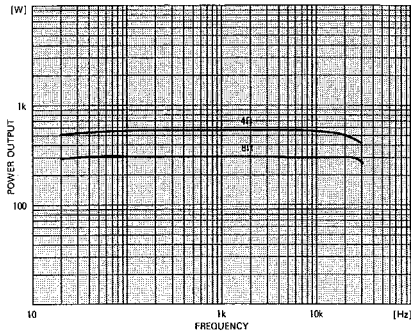

**LOAD IMPEDANCE vs POWER OUTPUT**

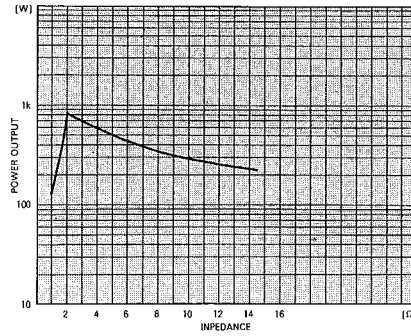

**FREQUENCY RESPONSE  
(BOTH CHANNEL DRIVEN)**

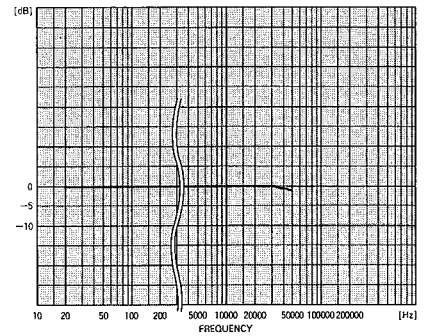

**T.H.D. vs FREQUENCY  
(BOTH CHANNEL DRIVEN)**

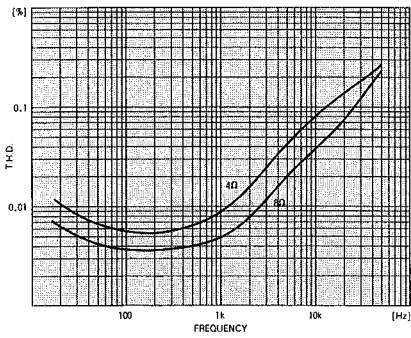

**T.H.D. vs POWER OUTPUT  
(BOTH CHANNELS DRIVEN)**

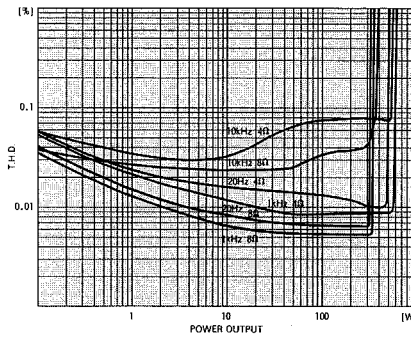

**INTERMODULATION DISTORTION  
VS POWER OUTPUT (ONE CHANNEL DRIVEN)  
MEASURED WITH A 4 : 1 MIX AT 60 Hz and 7 kHz**

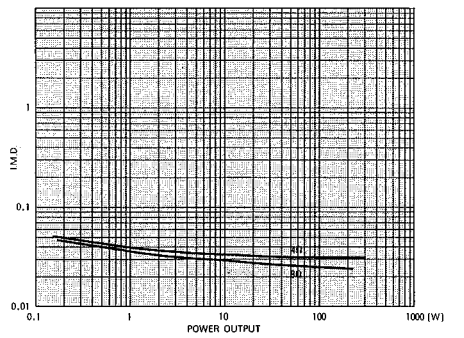

**DAMPING FACTOR vs FREQUENCY**

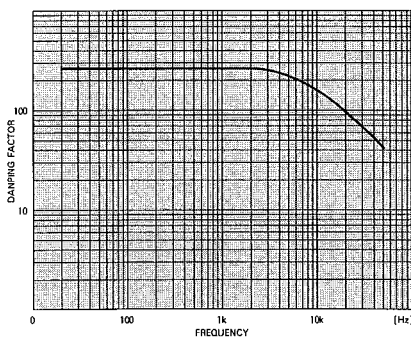

**ACTUAL OUTPUT IMPEDANCE  
vs FREQUENCY**

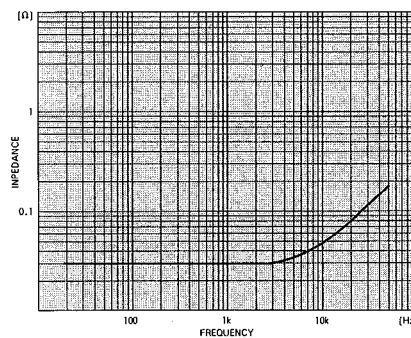

**CROSSTALK  
(BOTH INPUT ATTENUATORS  
AT MAXIMUM LEVEL)**

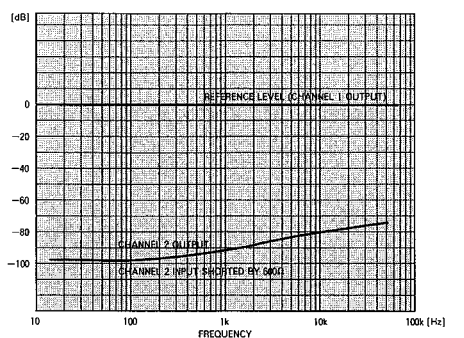

# Performance Graphs (P-300D)

**PHASE RESPONSE**

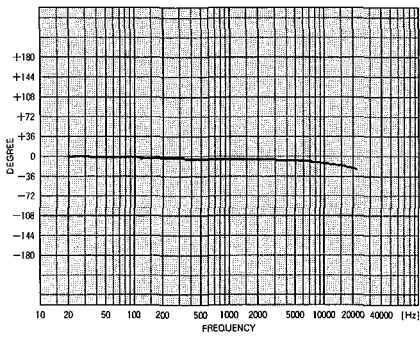

**POWER CONSUMPTION (BOTH CHANNEL DRIVEN)**

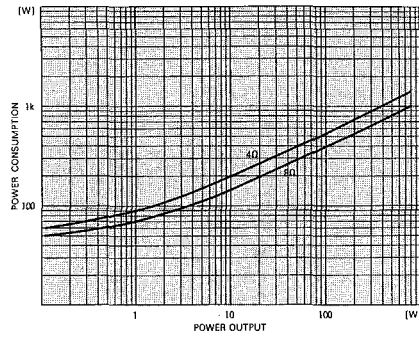

**POWER EFFICIENCY (BOTH CHANNEL DRIVEN)**

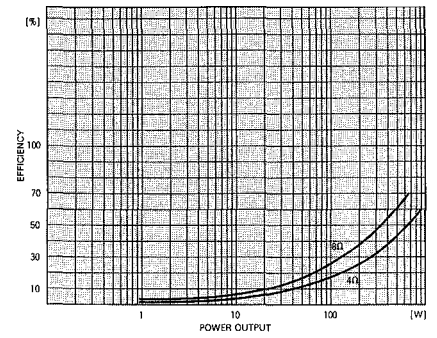

**POWER BANDWIDTH (MONO MODE)**

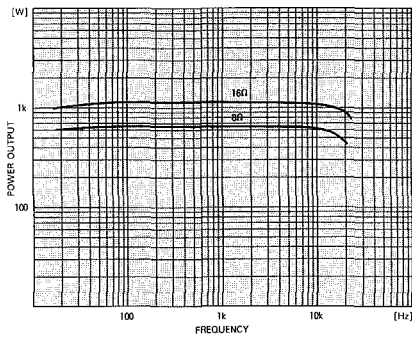

**LOAD IMPEDANCE vs OUTPUT POWER (MONO MODE)**

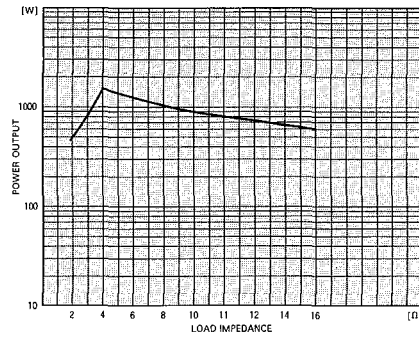

**FREQUENCY RESPONSE (MONO MODE)**

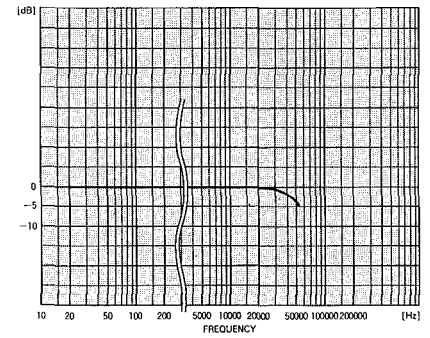

**T.H.D. vs FREQUENCY (MONO MODE)**

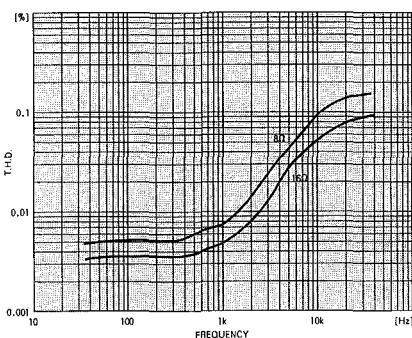

**T.H.D. vs OUTPUT POWER (MONO MODE)**

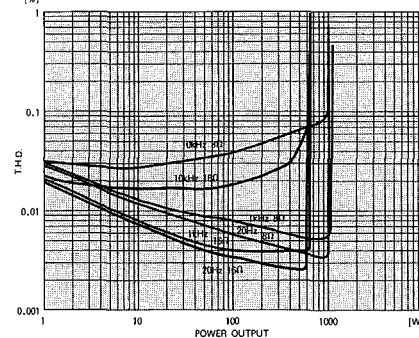

**POWER CONSUMPTION (MONO MODE)**

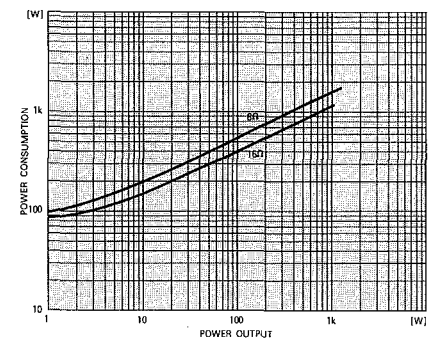

# Front Panel

## P-75D

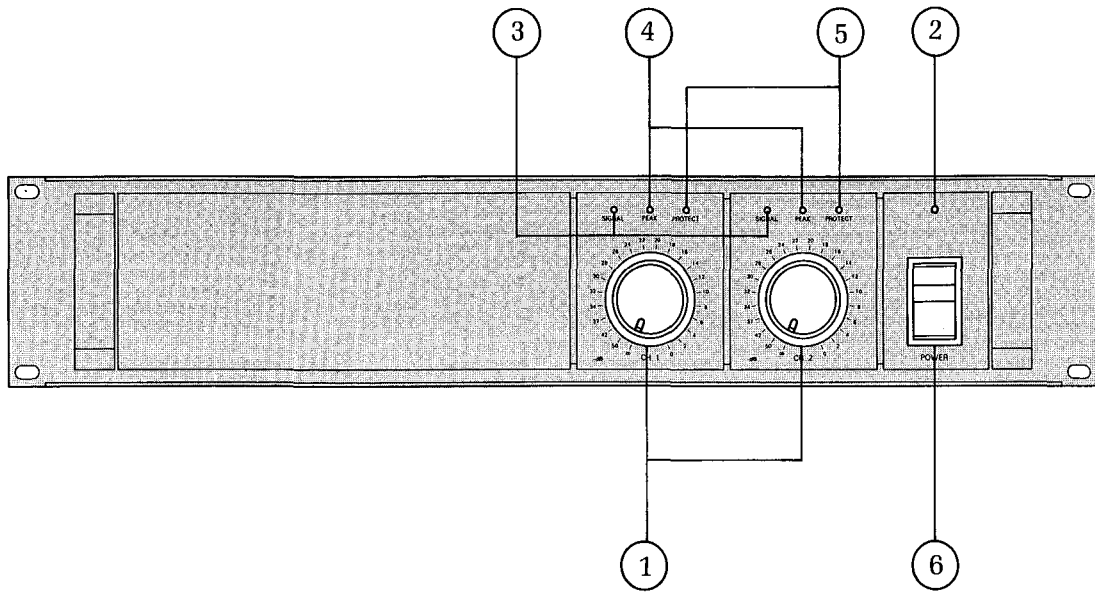

## P-150D

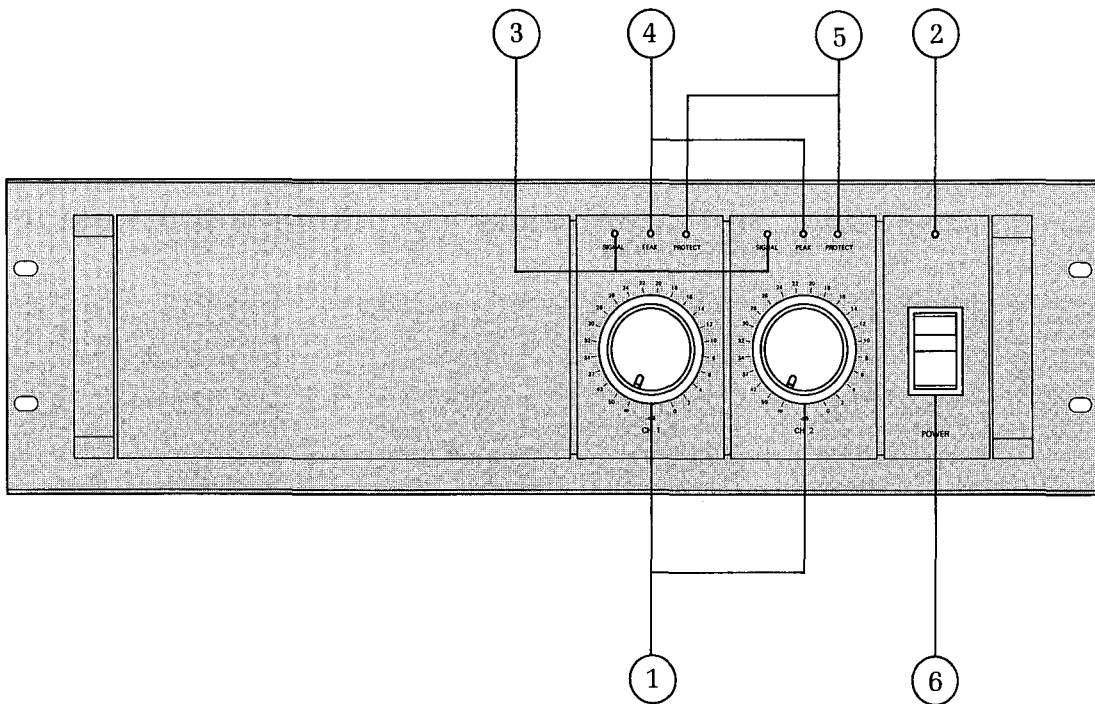

# Front Panel

## P-300D

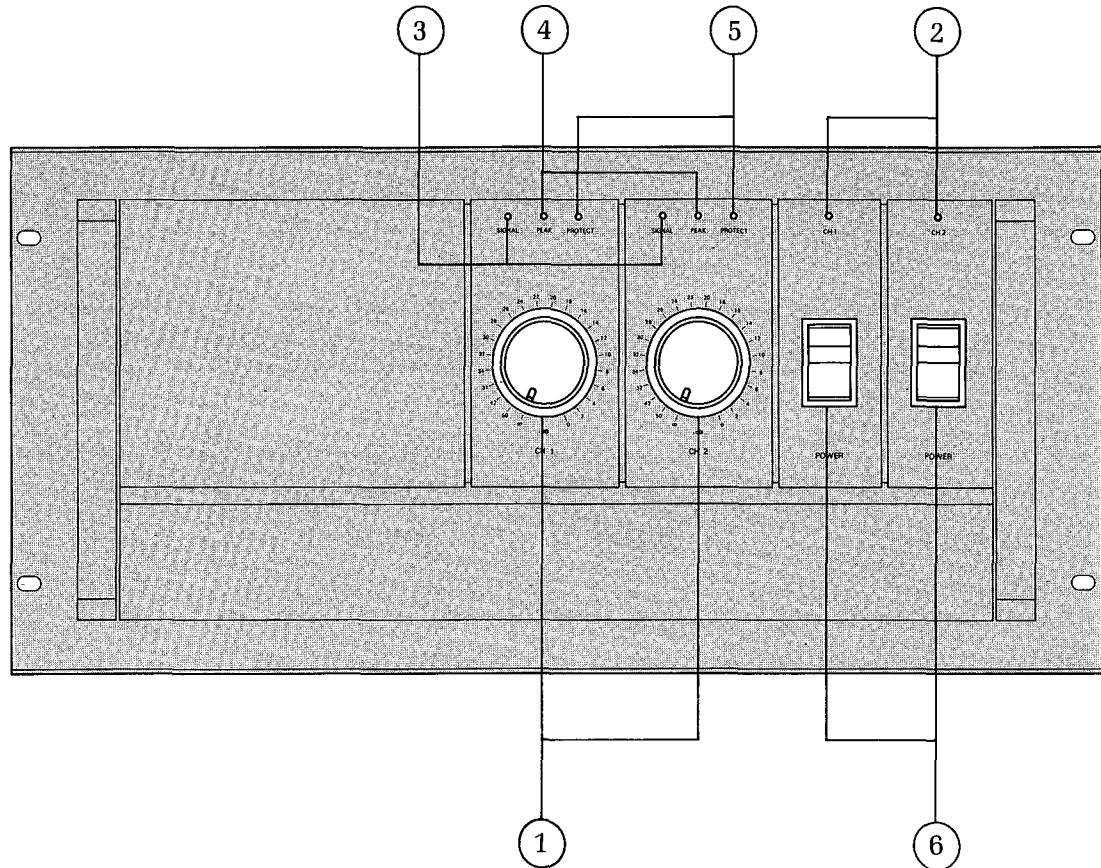

- ① **Input Attenuators**  
Calibrated in dB, detented input attenuators decrease input signal levels before the amplifier stage.
- ② **Power Indicator LED**  
The green LED glows when the power switch is "on".
- ③ **Signal Presence Indicator LED's**  
The LED's glow when more than  $-30$ dB level signal is fed to the inputs regardless of the input attenuator setting and output power level.
- ④ **Peak Indicator LED's**  
The peak indicator LED will glow when the amplifier reaches just below clipping. It is quite common for the LED to flash on and off during high level operation. However, if the LED remains steadily lighted, the input attenuator level should be lowered until the LED only flashes at the highest peaks.
- ⑤ **Protection Indicator LED's**  
These LED's remain lit for 3 seconds after the power switch has been turned on. They also come on when the protection circuit is activated, and flash when the temperature of the heat sinks exceeds  $105^{\circ}\text{C}$ . See Table "Fault Protection" on page 26.
- ⑥ **Circuit Breaker Power Switch**  
This switch is a combination circuit breaker and a power mains ON/OFF switch. If the circuit breaker trips, it may be reset by first setting to the "OFF" position and then returning to the "POWER ON" position, always check the amplifier and associated wiring before resetting the circuit breaker.

# Rear Panel

P-75D

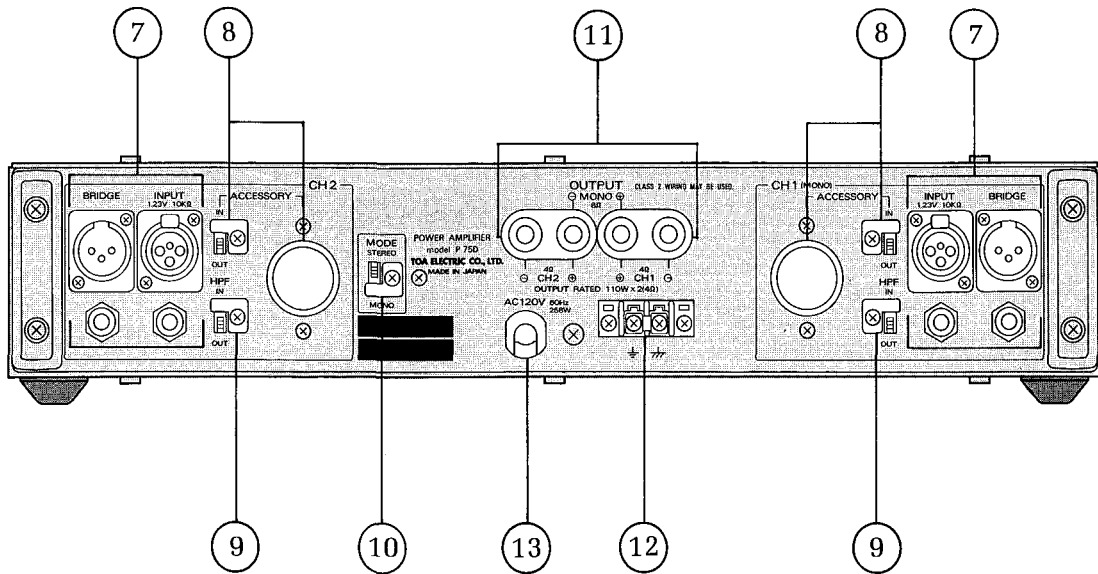

P-150D

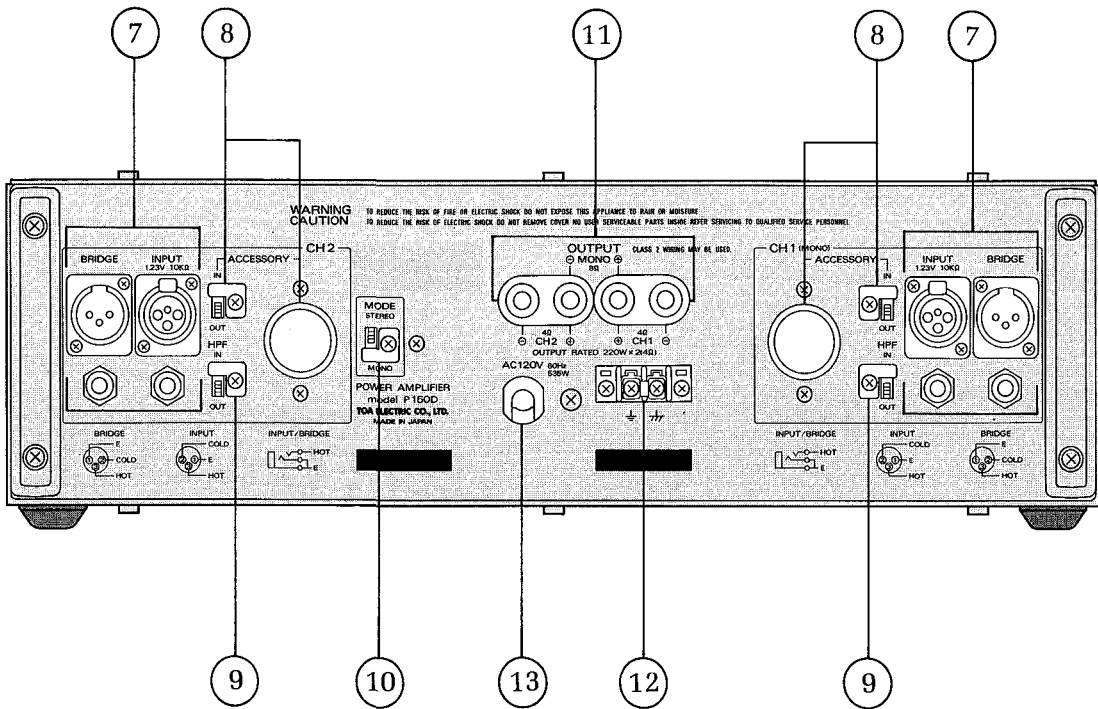

# Rear Panel

## P-300D

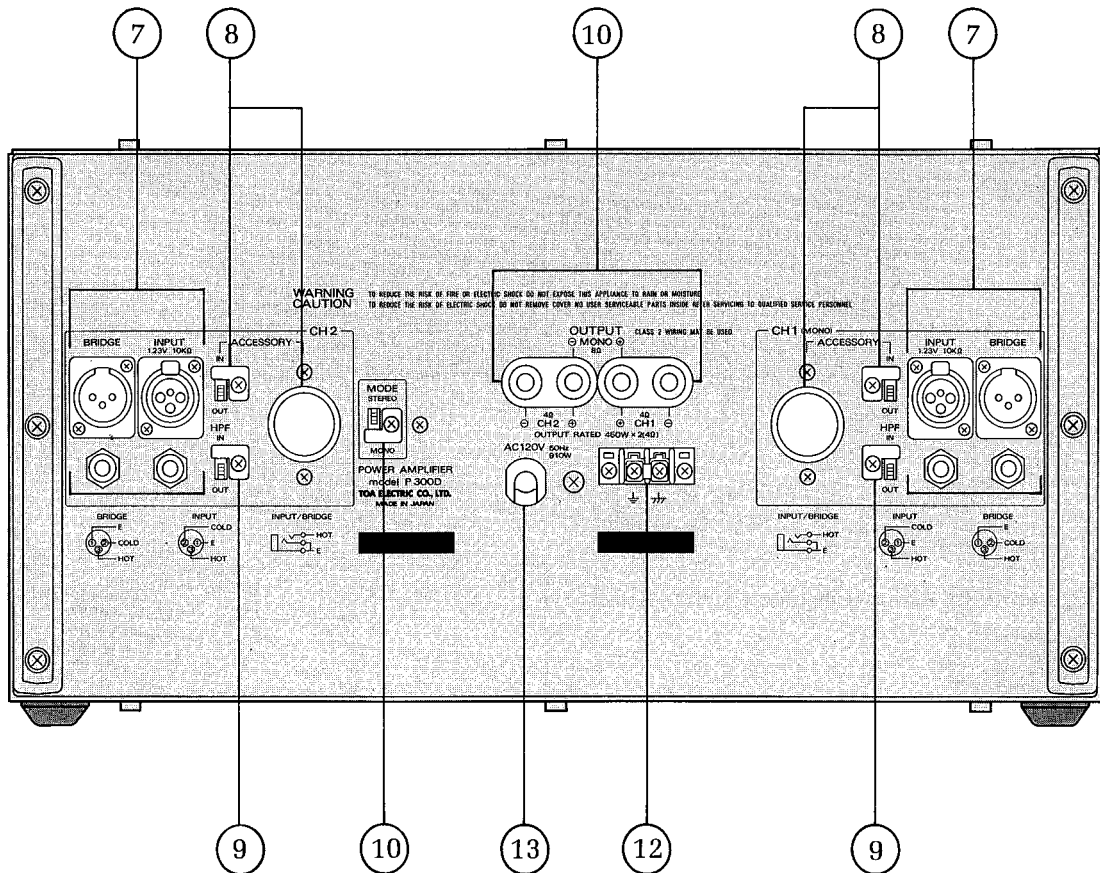

⑦ **Input connectors**

The two XLR input connectors on each channel are unbalanced and are wired in parallel with each other and with the two phone jacks that can accept tip/sleeve as well as a tip/ring/sleeve type of plug.

⑧ **Accessory**

To convert the XLR input connectors to balanced operation, remove the octal socket cover and insert the matching transformer (PU-101T). Then loosen the screw and set the In/Out switch to "In" after removing the L shaped metal fitting. You can prevent accidental change in switch position by attaching the metal fitting to the OUT side. The same metal fitting is used in the High Pass Filter Switch and Mode Switch on each channel to secure the desired switch position.

⑨ **High Pass Filter Switch**

A switchable 15Hz high pass filter (12dB/octave) prevents damage from subsonic frequencies.

⑩ **Mono/Stereo Mode Switch**

Place this switch in the STEREO position for dual amplifier use, and in the MONO position for single amplifier use.

⑪ **Output Connectors**

Standard 5-way binding posts (3/4" spacing) accept banana plugs or direct wired connections. For mono use, two red binding posts are used with the mode switch in the MONO position.

⑫ **Ground Terminal Strip**

Remove the strap to isolate chassis ground from signal ground. This may help prevent ground loop hums caused by multiple ground paths.

⑬ **AC Power Cord.**

# Input/Output Connections

## P-75D Typical Stereo Hookup

All XLR type connectors are unbalanced connection. The pin 1 and 2 ground (shield) the pin 3 hot (high, plus).

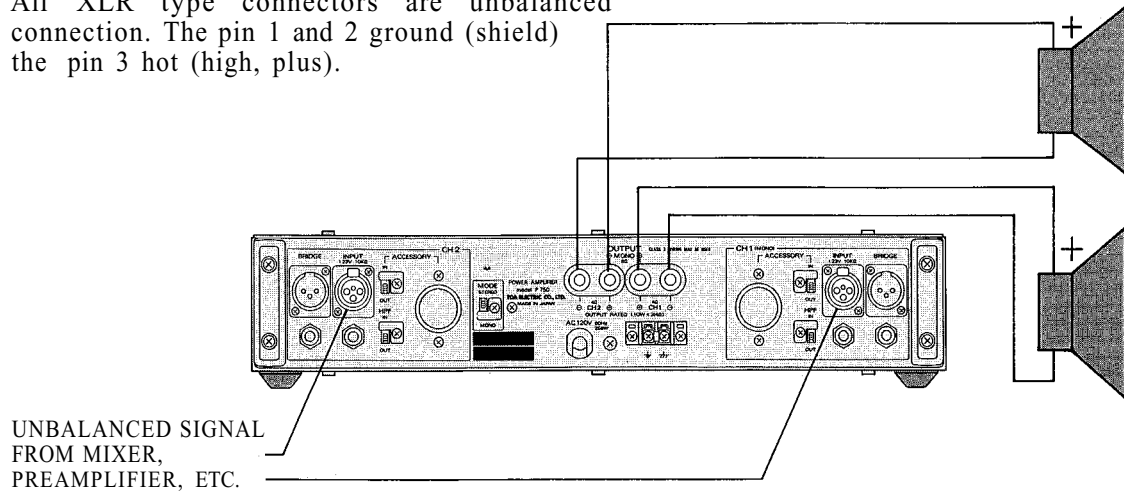

All Phone jacks are unbalanced connection.

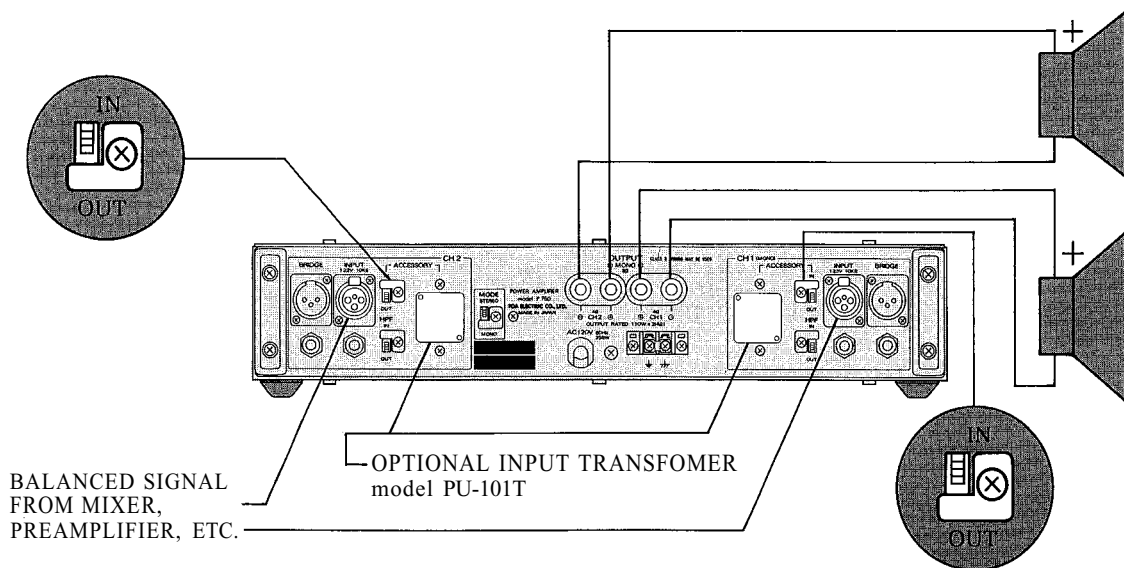
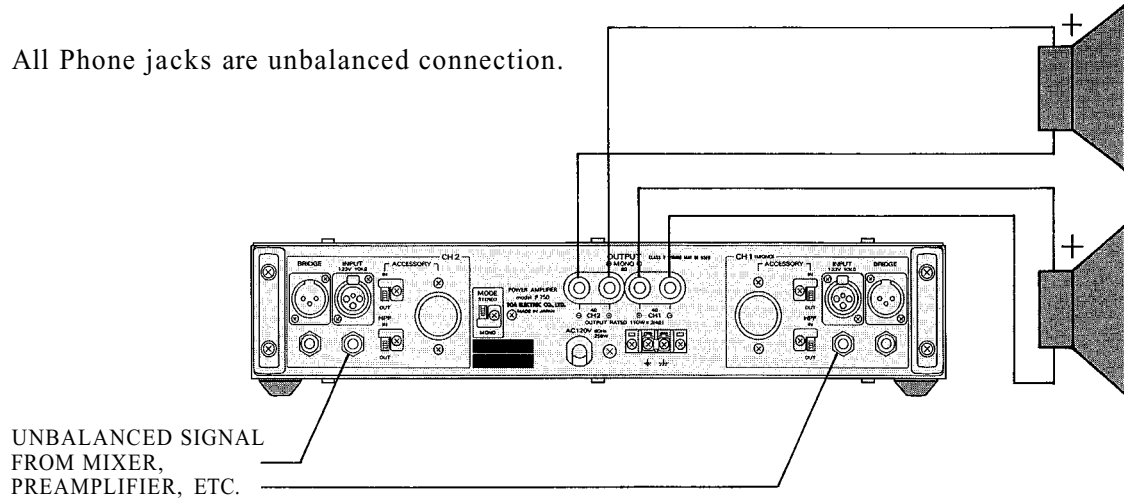

The pin 1 ground (shield), the pin 2 cold (Low, minus), the pin 3 hot (high, plus).

# Input/Output Connections

## P-75D Typical Mono Hookup

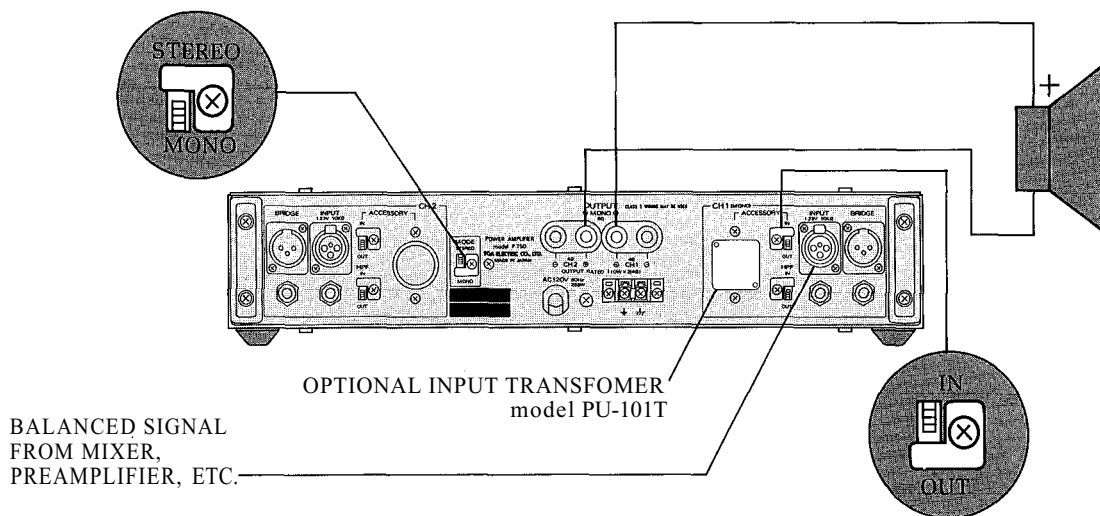
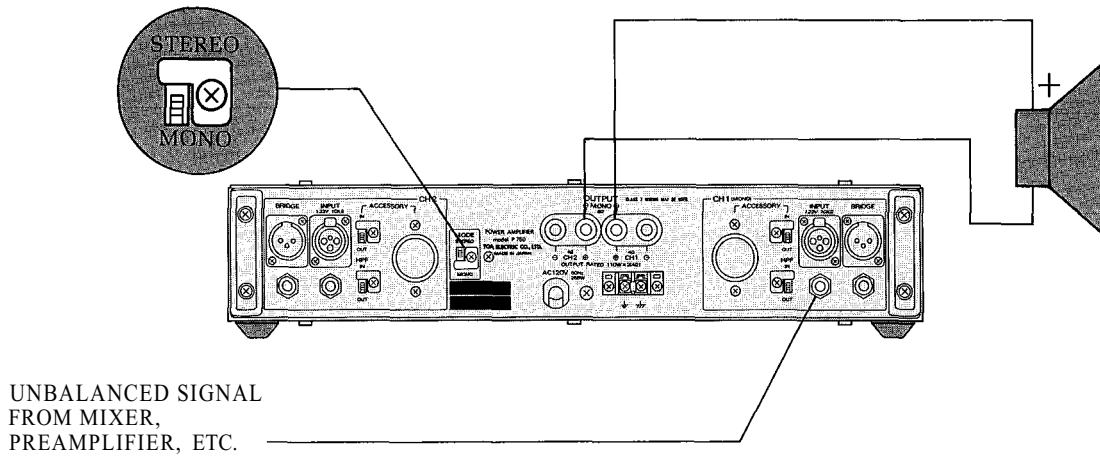
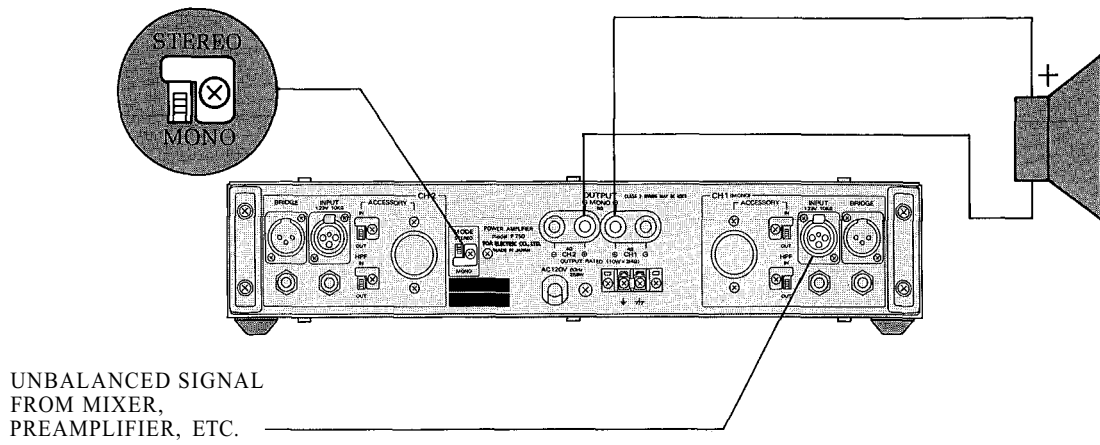

For balanced connection, all devices involved need to be of balanced type. When extending the amplifier using the bridge terminal of the P-75D, insert the PU-101T matching transformer into the octal socket marked "ACCESSORY", and set the ACCESSORY IN/OUT switch to IN.

# Input/Output Connections

## P-150D Typical Stereo Hookup

All XLR type connectors are unbalanced connections.

The pin 1 and 2 ground (shield), the pin 3 hot (high, plus).

UNBALANCED SIGNAL FROM MIXER, PREAMPLIFIER, ETC.

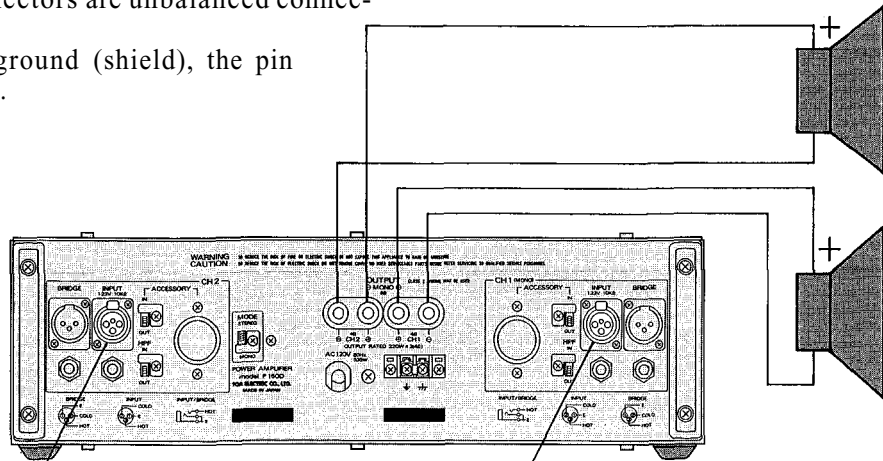

All Phone jacks are unbalanced connections.

UNBALANCED SIGNAL FROM MIXER, PREAMPLIFIER, ETC.

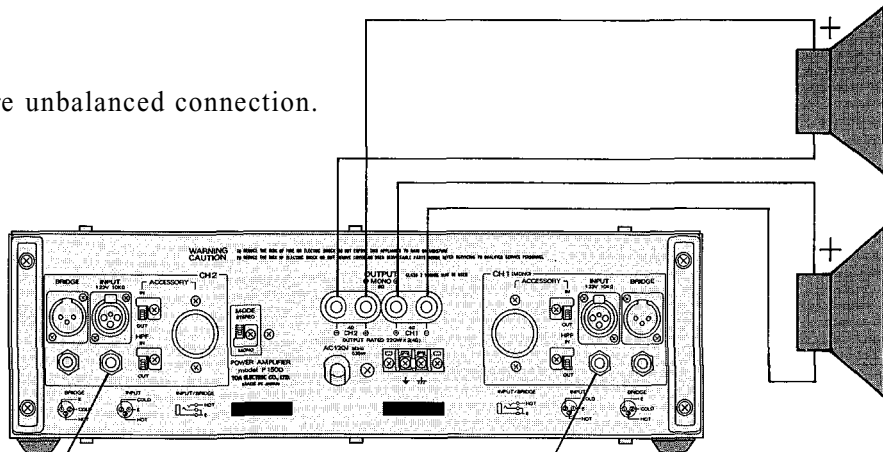

BALANCED SIGNAL FROM MIXER, PREAMPLIFIER, ETC.

OPTIONAL INPUT TRANSFORMER model PU-101T

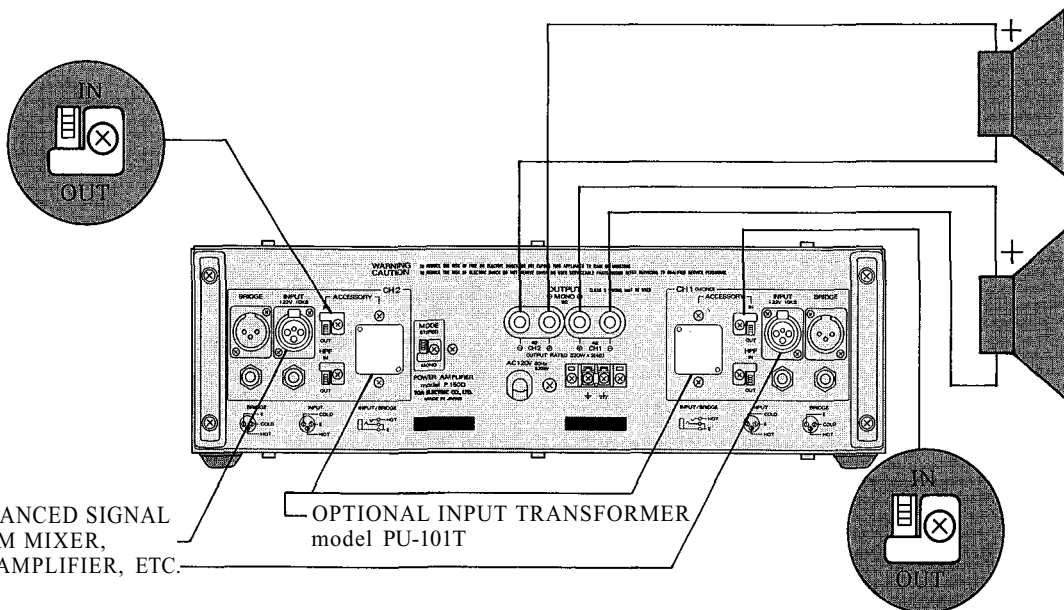

The pin 1 ground (shield), the pin 2 cold (low, minus), the pin 3 hot (high, plus).

# Input/Output Connections

## P-150D Typical Mono Hookup

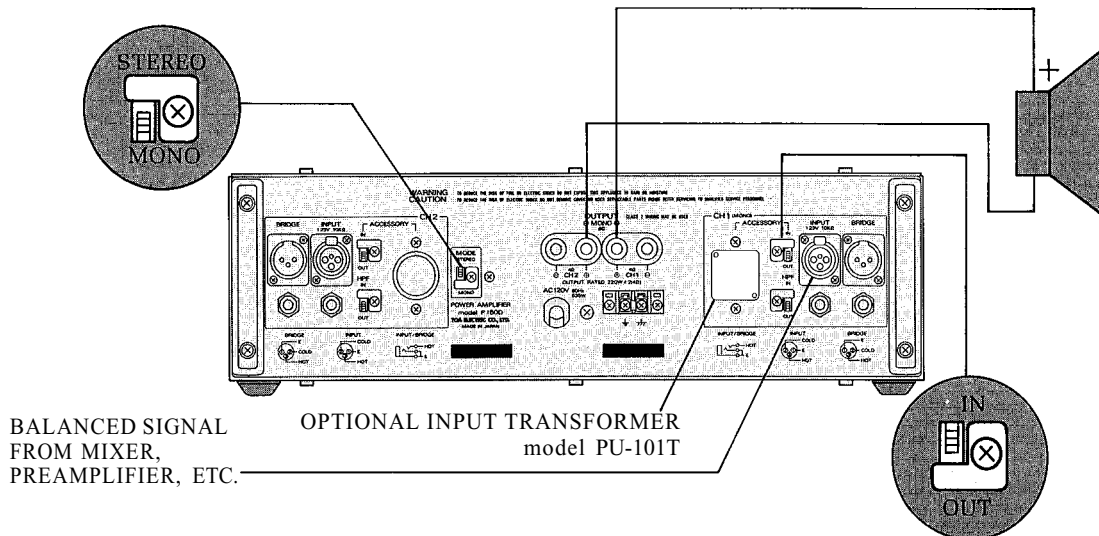
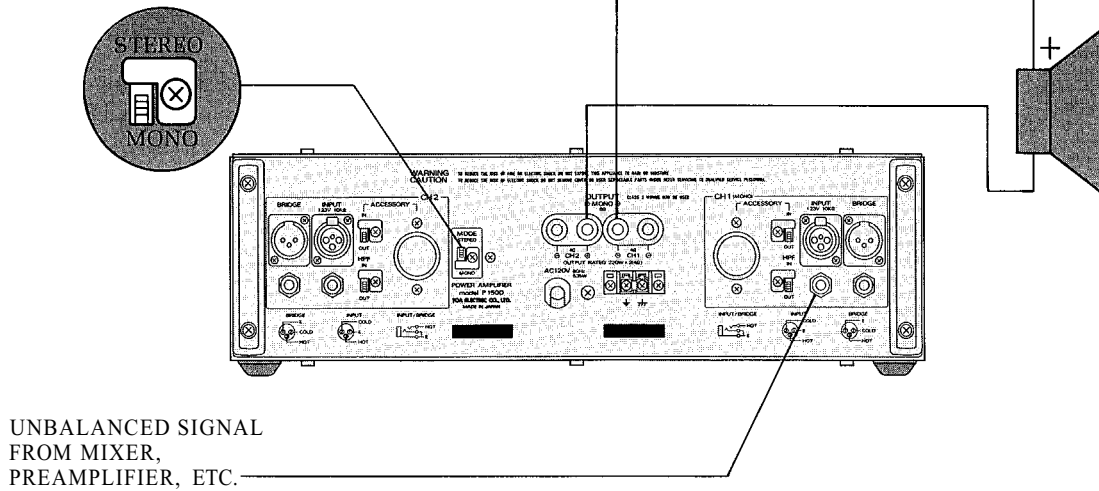
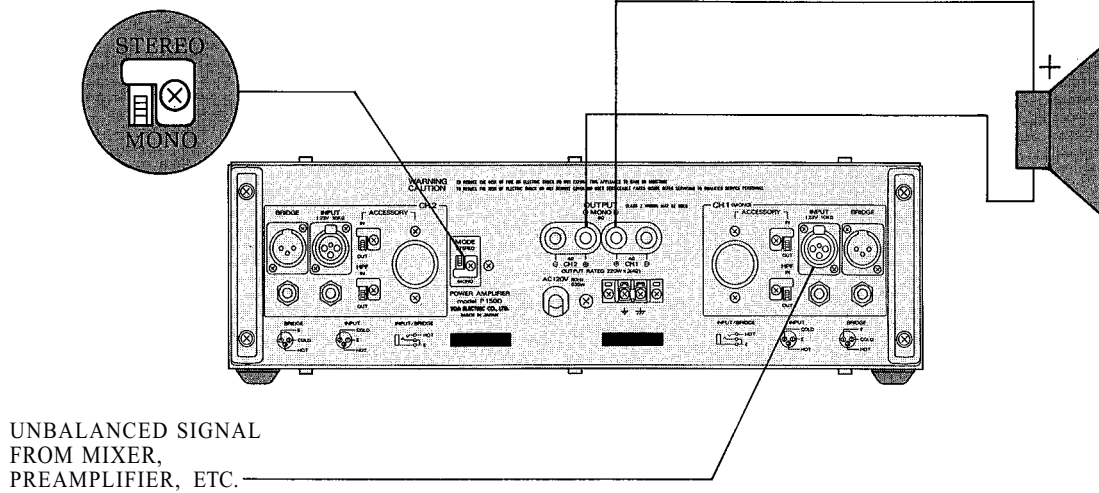

For balanced connection, all devices involved need to be of balanced type. When extending the amplifier using the bridge terminal of the P-75D, insert the PU-101T matching transformer into the octal socket marked "ACCESSORY", and set the ACCESSORY IN/OUT switch to IN.

# Input/Output Connections

## P-300D Typical Stereo Hookup

All XLR type connectors are unbalanced connection.  
The pin 1 and 2 ground (shield),  
the pin 3 hot (high, plus).

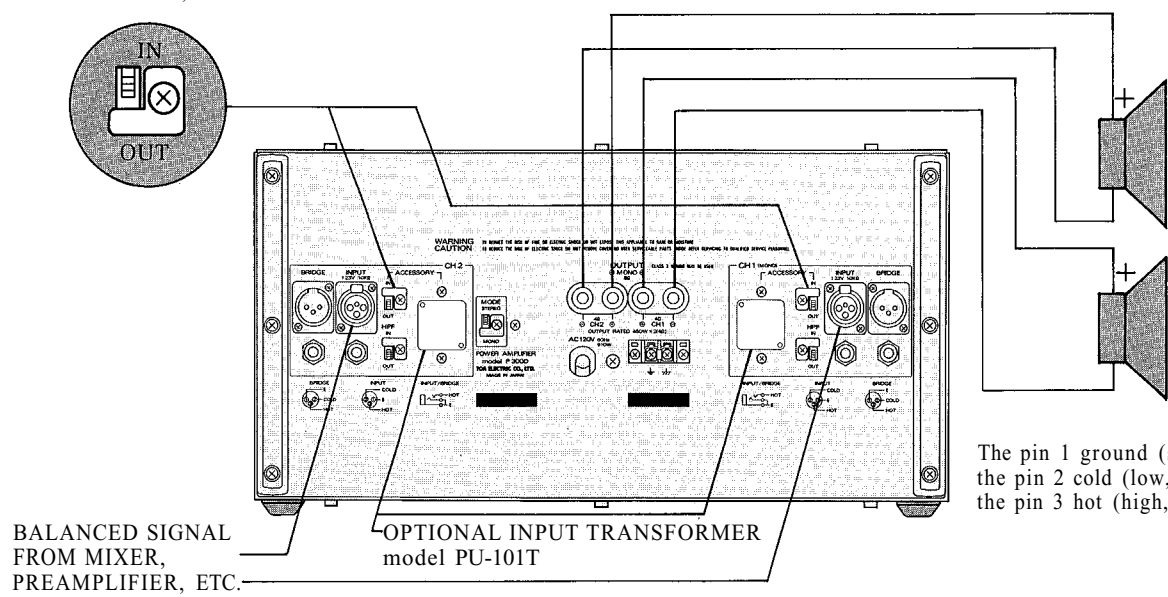
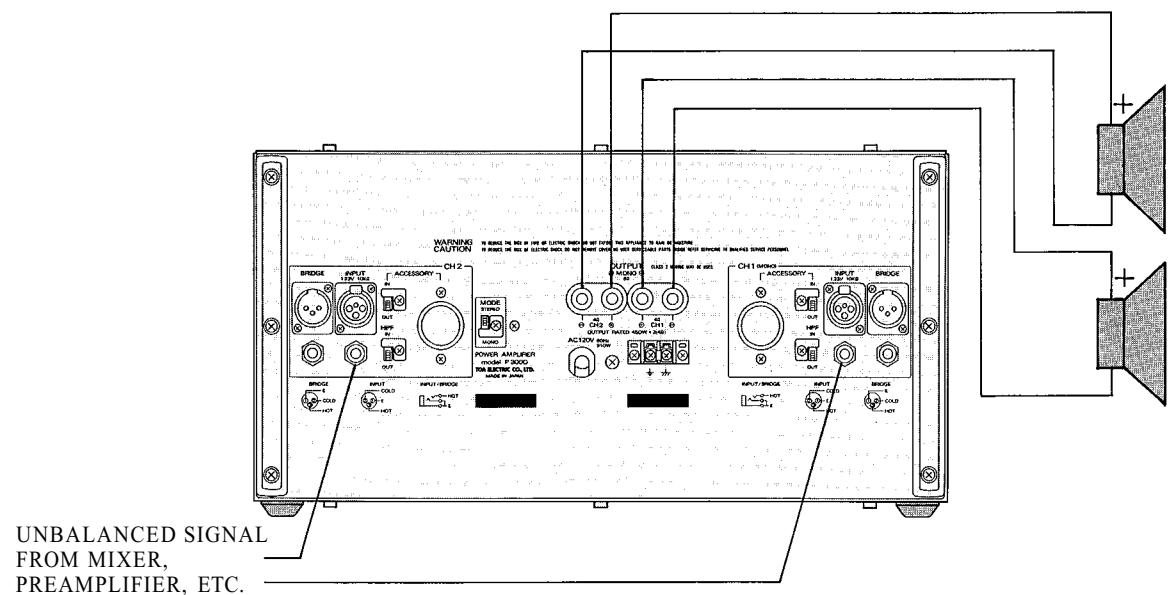
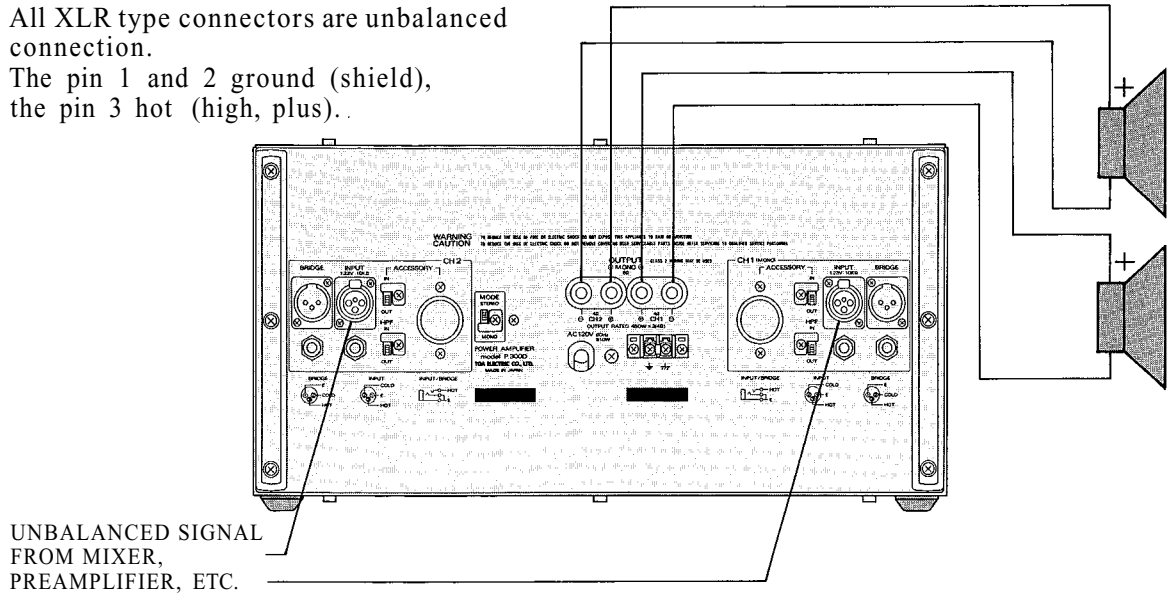

The pin 1 ground (shield),  
the pin 2 cold (low, minus),  
the pin 3 hot (high, plus).

# Input/Output Connections

## P-300D Typical Mono Hookup

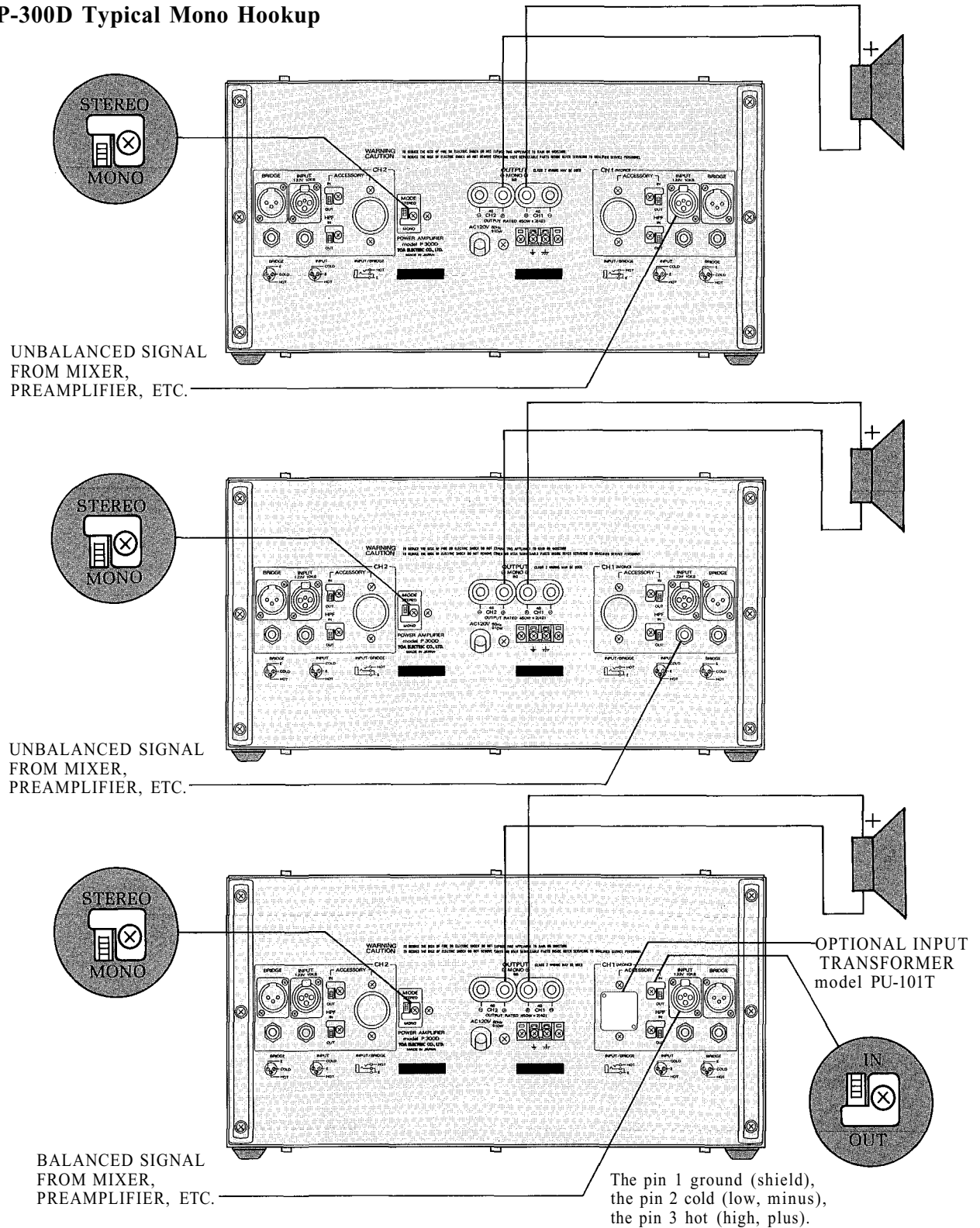

For balanced connection, all devices involved need to be of balanced type. When extending the amplifier using the bridge terminal of the P-75D, insert the PU-101T matching transformer into the octal socket marked "ACCESSORY", and set the ACCESSORY IN/OUT switch to IN.

# Installation Precaution

## Input and output cables

In view of high power output produced, separate the input cable from the output cable when installing the P-75D, P-150D or P-300D. If they are in close proximity to each other, oscillation may occur. Particular care should be given to the wiring when mounting unit in a rack cabinet.

## Ground Loops

In any audio system, there are numerous ways by which ground loops can be created. For example, they may occur when the P-75D, P-150D and P-300D are mounted in a rack cabinet, or through AC ground when the amps are connected with preamps and mixers. These ground loops may cause hum and noise if care is not taken during connection. An increase in noise from ground loops may be minimized by breaking the ground loop. Generally, the chassis ground of the signal line should be broken as shown below.

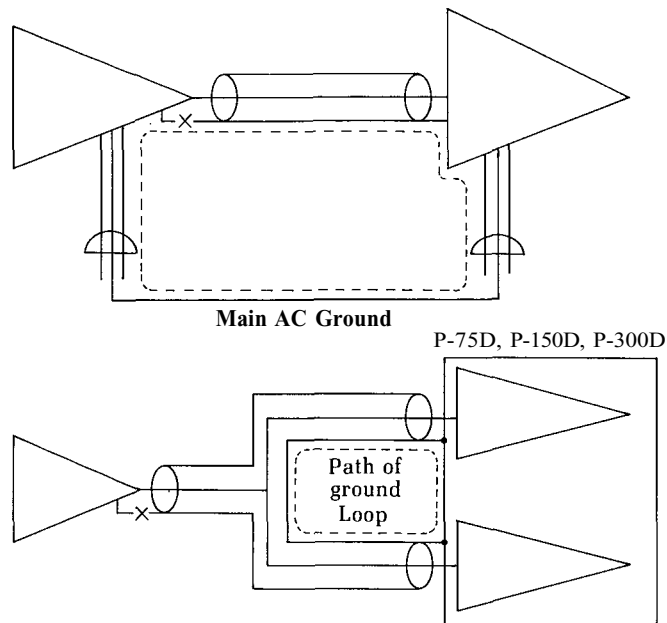

When a Y cord is used, shorten the wiring to minimize noise.

A ground lift terminal is provided on the rear of the P-75D, P-150D and P-300D. Removing the bar in the terminals lifts ground.

Since the P-75D, P-150D and P-300D are high power amplifiers, be careful with ventilation when they are installed. Do not block vents on the top pane. See sketch.

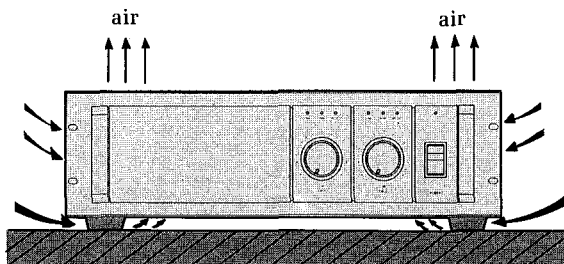

# Installation Precaution

## Mounting in an enclosed rack cabinet

The P-75D, P-150D and P-300D are mountable in a standard 19" rack. When mounting, insert a 1-unit-sized perforated panel between the units mounted, and place the same at the bottom of the rack. Be sure to mount a perforated panel larger than 1 unit size at the top of the rack. This is required to allow adequate heat ventilation. See illustration.

P-75D or  
P-150D or  
P-300D

P-75D or  
P-150D or  
P-300D

P-75D or  
P-150D or  
P-300D

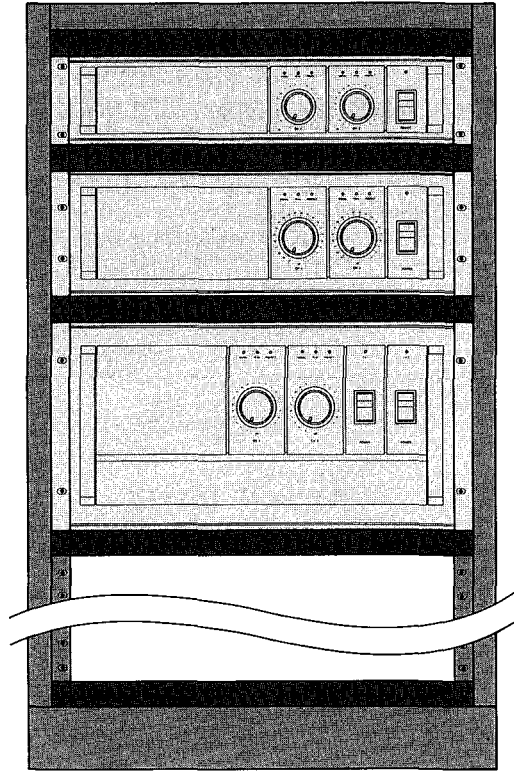

## On the road use.

The P-75D, P-150D and P-300D are sturdily constructed with an aluminum die-cast front panel that is reinforced by means of an iron plate attached to its back. To ensure that strength is maintained during their transportation from one place to another, however, you should also reinforce each unit from the back of the rack with a special support bracket. This can be accomplished by removing cord-hangers on the rear panel, and screws that hold the rear panel to chassis, and fitting the special support brackets through the holes.

Top view

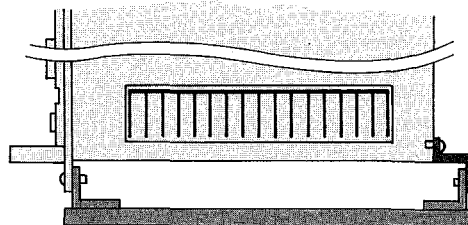

Special support bracket

Side view

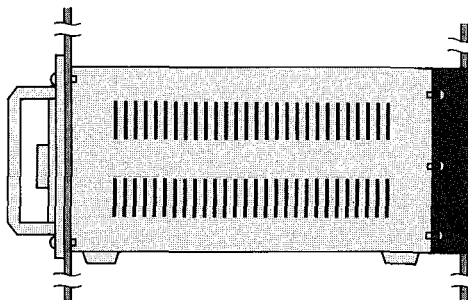

# Installation Precaution

## Mono Operation

The P-75D, P-150D and P-300D are designed to be used as mono amplifiers by placing their mode switches in mono positions. In the mono mode total speaker impedance should not be lower than 8 ohms.

## Source Resistance and Damping Factor vs. Length and Size of Output Leads

The following figure indicates that a 100 foot length of # 14 AWG annealed copper wire (two conductor) yields a combined amplifier/cable source impedance of 0.5 ohms. A typical 8 ohms load impedance is indicated, and this results in an effective damping factor of 15. (This damping factor is less than the rated one of each model obtained with zero ohms cable resistance). Larger diameter (lower wire gauge number) should be used for longer cable.

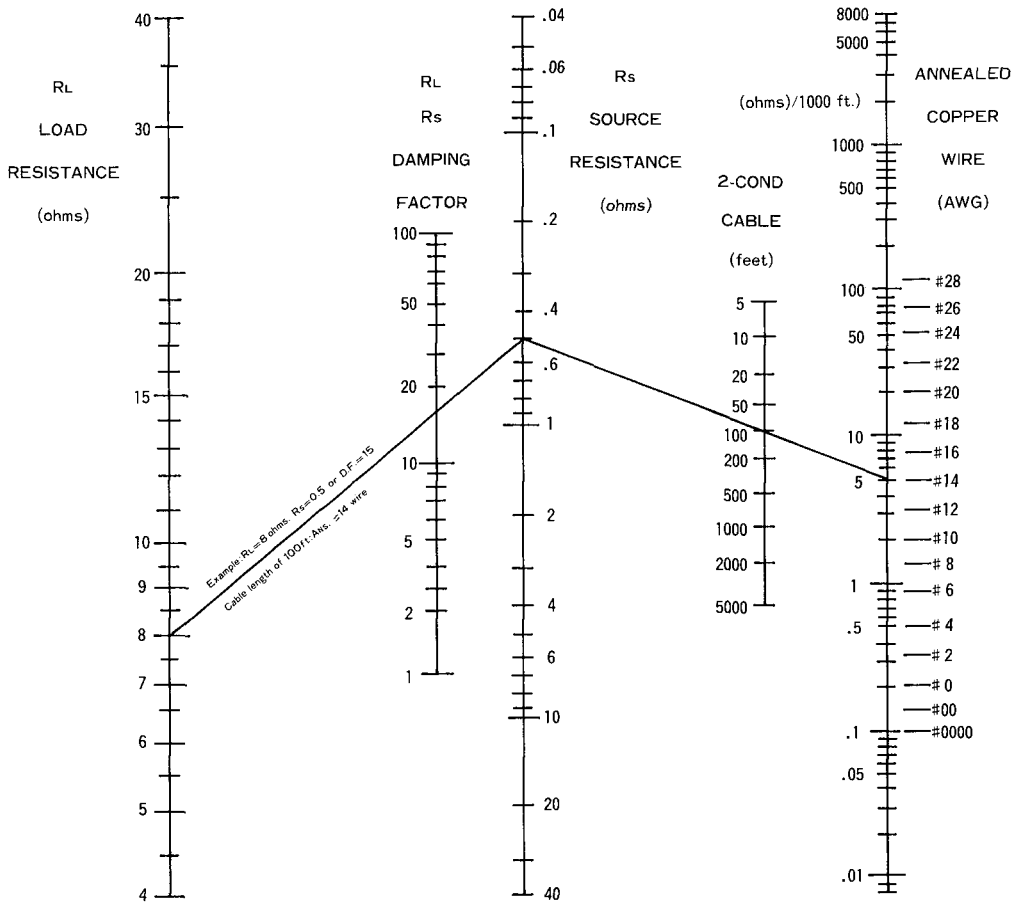

# Installation Precaution

## Load Protection Methods

The most common of all load protection methods is a fuse in series with the load. The fuse may be single, fusing the overall system, or (in the case of multi-element speaker systems), may be multiple with one fuse for each speaker. Fuses help prevent damage due to prolonged overload, but provide essentially no protection against damage that may be done by large transients. To minimize the problem, high speed instrumentation fuses are recommended. For a nomograph showing fuse size vs. loudspeaker ratings, refer to the adjacent figure.

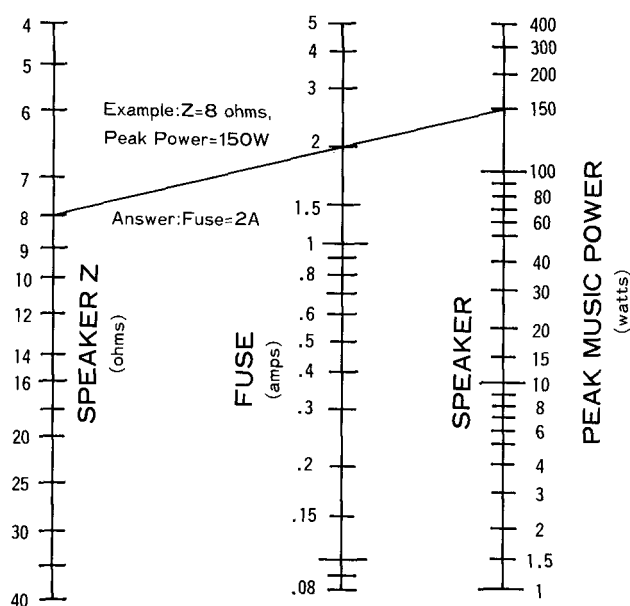

**Fault Protection Table**

Fault	Protection	Indication	Action	Restoration
Excessive current due to overloads.	Current limiter activates at less 2 ohms in a stereo mode, 4 ohms in a mono mode.	Peak LED illuminates.	Remove excessive loads. Minimum speaker loads are 4 ohms in stereo mode, and 8 ohms in mono mode.	Automatic restoration after normal loads are obtained.
Short circuits (less than 0.4-ohm).	Current limiter activates and output relay is cut.	Protection LED illuminates.	Check speaker lines/systems for shorts.	Turn off power switch. Turn on into operational loads.
Temperature rise of heatsink (more than 105°C).		Protection LED flashes.	Check for adequate ventilation.	Automatic restoration after temperature lowers (to 75° - 95°C).
DC drift.	Output relay is cut.	Amp protection LED illuminates.	Refer to qualified service personnel.	Automatic restoration after normal bias is regained.

# Appearance

**P-75D**

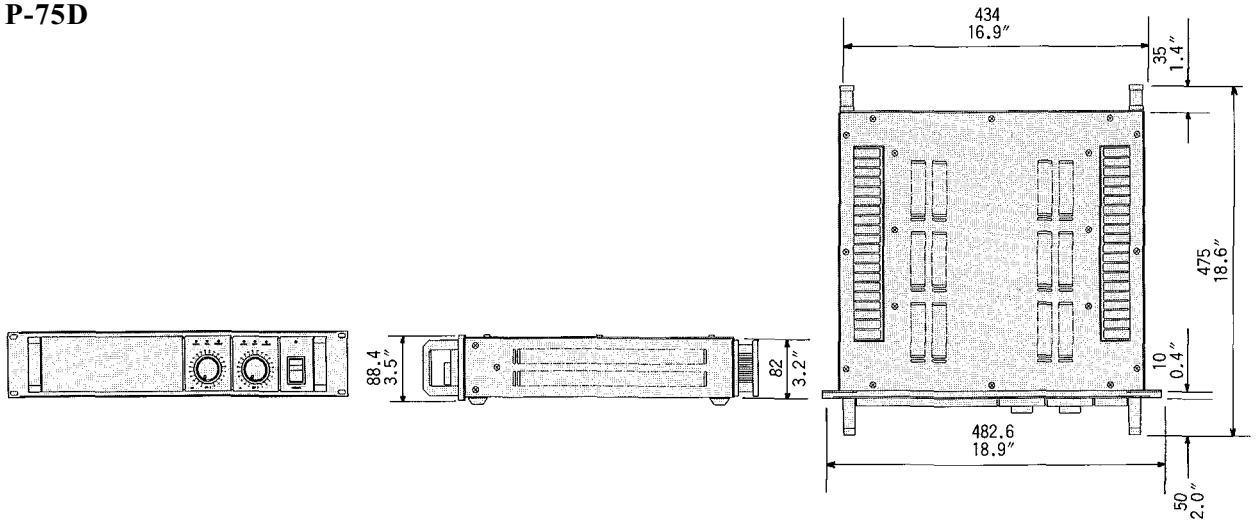

**P-150D**

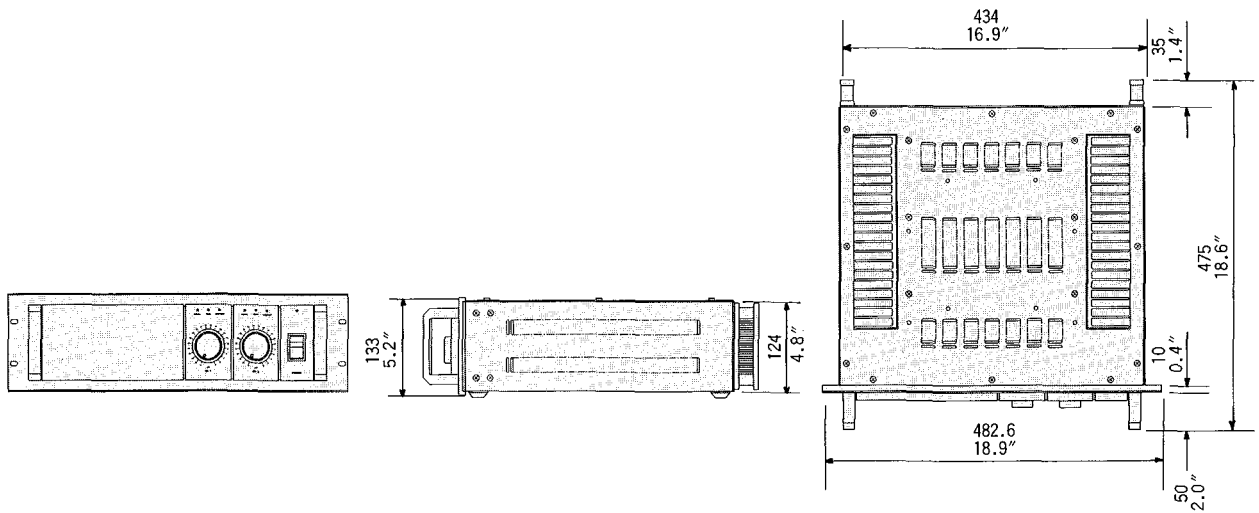

**P-300D**

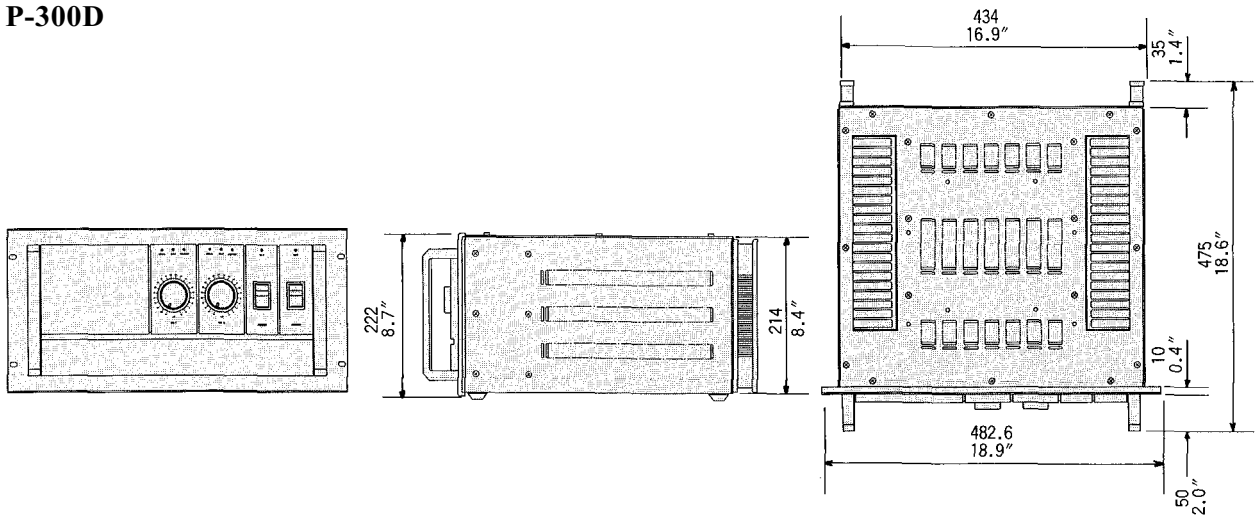



**TOA Corporation**  
KOBE, JAPAN