

May 20, 1969

J. E. KARLSON

3,445,852

OPEN END WAVEGUIDE ANTENNA

Filed Feb. 5, 1968

Sheet 1 of 2

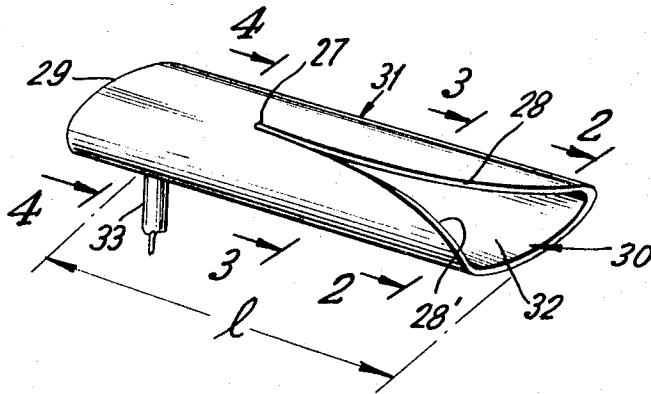

FIG. 1

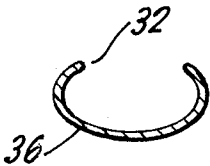

FIG. 2

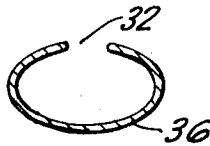

FIG. 3

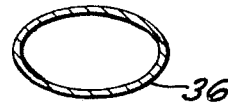

FIG. 4

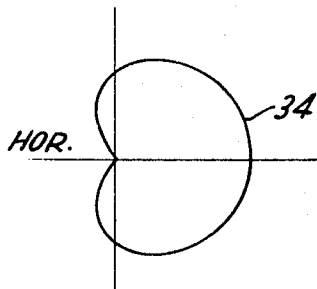

FIG. 5

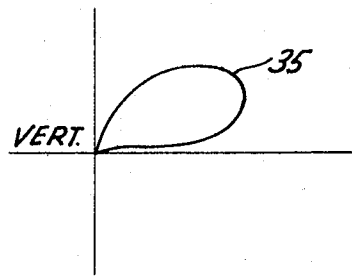

FIG. 6

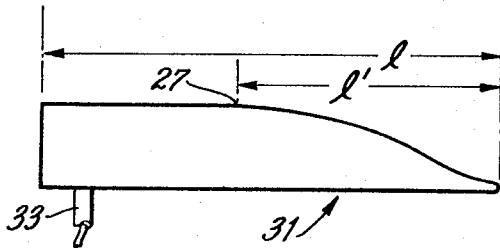

FIG. 1A

INVENTOR.

JOHN E. KARLSON

BY

Henry H. Henry

ATTORNEYS

May 20, 1969

J. E. KARLSON

3,445,852

OPEN END WAVEGUIDE ANTENNA

Filed Feb. 5, 1968

Sheet 2 of 2

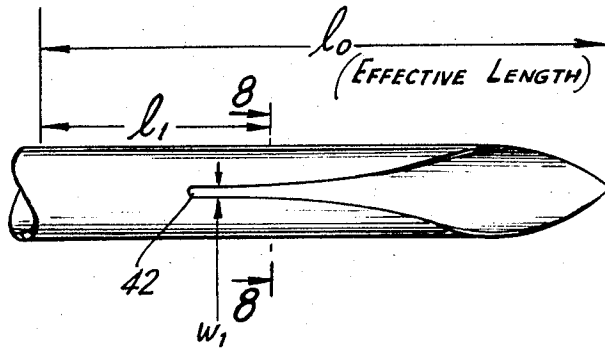

FIG. 7

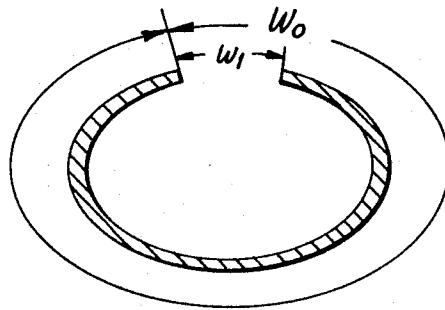

FIG. 8

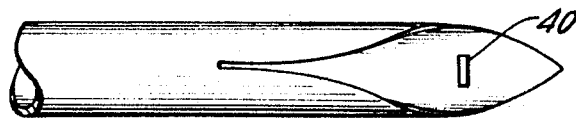

FIG. 9

INVENTOR.
JOHN E. KARLSON

BY *Kerrison Kerrison*

ATTORNEYS

1

2

3,445,852

OPEN END WAVEGUIDE ANTENNA

John E. Karlson, 423 Bedell Terrace,
West Hempstead, N.Y. 11552

Continuation-in-part of application Ser. No. 486,392,
Sept. 10, 1965. This application Feb. 5, 1968, Ser.
No. 703,081

Int. Cl. H01q 13/02

U.S. Cl. 343-772

6 Claims

ABSTRACT OF THE DISCLOSURE

This invention relates to a design for microwave waveguide antennas. Basically, the invention is directed toward providing a waveguide structure with a particular geometrical configuration to condition the microwave energy passing therethrough. Specifically, the unique feature of this invention is a tapered aperture or slot in the wall of the waveguide antenna; which tapering aperture extends from its open end and gradually narrows down to a much smaller opening in the tubular structure. The aperture or slot down the length of the waveguide has its greatest transverse width dimension at or near the opening of the tubular structure. The dimension of the width at this point is greater than one-half the width of the waveguide and the configuration of the aperture is that of a convergent slot reducing in width to a point where the aperture terminates. The length of the tubular structure is associated with the microwave antenna.

CROSS REFERENCE TO RELATED APPLICATIONS

This invention is a continuation-in-part application of application No. 486,392 filed Sept. 10, 1965, now abandoned, by John E. Karlson.

FIELD OF THE INVENTION

This invention is directed to tubular structures through which microwave energy passes and in particular, to microwave antennas.

DESCRIPTION OF THE PRIOR ART

Presently, the state of the art includes the broad concept of applying the critical geometrical design of the invention; i.e., the tapered aperture, in a coupling chamber for loud speakers. This advance is disclosed in Patent 2,816,659 issued on Dec. 17, 1957, to John E. Karlson. The Karlson patent (2,816,659) is directed to providing a design for coupling chambers having acoustical application which chamber incorporates the critical geometry of the subject tapered aperture. The utility of providing a tapered aperture in a pipe through which sound waves are passing is explained as is the theory of the phenomenon occurring as sound waves pass through the tapered aperture.

By experimentation, the inventor has found that microwave waveguide antennas can be provided with a tapered aperture similarly configured to the aperture used in acoustical coupling chambers to facilitate broad band operation and highly desirable dispersion patterns of microwave energy.

The tubular structure 31 with a long tapered aperture 32 and curved side walls seen in FIG. 1 is for conditioning the energy passing through the tubular structure 31 and for obtaining the dispersion patterns shown in FIGS. 5 and 6. The same rules apply in this case as for sound projectors, except that the low frequency cutoff would be determined by the cross-sectional dimensions of the antenna structure. A coaxial feed 33 is used to activate this antenna or to pick up signals received by this antenna. As in the previous cases, the transmission and reception

patterns of such antennas are essential reciprocal. A microwave antenna of this type would be especially valuable for simultaneous microwave communications with many widely separated stations. Many other applications will suggest themselves to those skilled in the art of Doppler and pulse radar.

The object of this invention is to provide a broad band waveguide antenna of unique dispersion and/or reception characteristics. These characteristics are made possible by the use of a relatively long tapered aperture in the waveguide wall which has its greatest width at or near the open end of the waveguide and extends back along its length while gradually narrowing down to a relatively small opening. The broad banding of this waveguide structure is accomplished through extending the length of this tapered aperture relative to the broad band requirements. When the length of this tapered aperture extends more than two thirds of the effective length of the waveguide antenna proper this broad banding can be extended to provide a smooth response over a number of octaves. The dispersion pattern created by this invention is broad in one plane (x plane) and narrow in the other (y plane). The dispersion in the broad x plane remains relatively constant with frequency while the dispersion in the y plane becomes narrower with increase in frequency and/or length of the tapered aperture. Perfection of the frequency response and dispersion characteristics can be attained through the use of specific curvatures in the waveguide walls and by control of the rate of flare and length of the tapered aperture.

DESCRIPTION OF THE DRAWINGS

The invention will be described further by way of example with reference to the drawings wherein:

FIG. 1 is a perspective view of a tubular microwave antenna showing the tapered aperture of the subject invention.

FIG. 1A is a side view of the tubular microwave antenna of the subject invention.

FIG. 2 is a cross sectional view taken through lines 2-2 of FIG. 1;

FIG. 3 is a cross sectional view taken through lines 3-3 of FIG. 1.

FIG. 4 is a sectional view of FIG. 1 through lines 4-4;

FIG. 5 is a dispersion pattern for the microwave energy passing, in the horizontal plane, through the terminal opening of the microwave antenna of FIG. 1;

FIG. 6 is a dispersion pattern for the microwave energy passing, in the vertical plane, through the terminal opening of the microwave antenna of FIG. 1.

FIG. 7 is a side view of a microwave waveguide antenna having the tapered slot of the subject invention configured to optimum relative dimensions.

FIG. 8 is a sectional view of FIG. 7 through lines 8-8.

FIG. 9 is a side view of a microwave waveguide antenna having the subject tapered aperture, curved walls opposing the tapered aperture and a protuberance arranged therein.

DESCRIPTION OF THE PREFERRED EMBODIMENT

As best seen in FIG. 1 a tubular microwave antenna 31 is provided with a tapered aperture 32 to effect optimum microwave dispersion. Basically, the microwave antenna 31 has provided therefor, a coaxial feed 33 through which microwave energy is introduced into the antenna 31 or passed therefrom. To this end, the microwave antenna 31 is adapted to function as both a receiving and transmitting antenna. Structurally, the antenna 31 is closed at one end 29 and open at the opposite end 30. Microwave energy being transmitted is either directed initially through opening 30 or reflected from the interior housing of the antenna 31. Conversely, reception of microwave energy

is facilitated by the provision of opening 30 through which entering microwave energy passes and either reflects into coaxial feed 33 or passes thereinto directly. It should be noted that the provision of a coaxial feed 33 is optional and a waveguide will also perform satisfactorily in this assembly.

To achieve optimum operation for both transmitting and receiving microwave energy the antenna 31 is provided with a focusing system defined by a tapered aperture 32 which extends from the terminal opening 30 convergently to a point on the body of antenna 31 which is of a length l' (FIG. 1A) of a dimension at least greater than one-half the length l of the tubular antenna 31. The configuration of the tapered aperture 32 is that of a tapering slot which follows lines 28 and 28' from opening 30 to point 27. As best seen in FIG. 2 the width of the tapered aperture 32 is greatest at terminal opening 30 of the antenna 31.

The width of the tapered opening must be greatest at the microwave waveguide antenna opening to achieve a good result. Moreover, it has been found that near optimum dispersion (or reception) and frequency characteristics are obtained through the use of elliptical waveguides with the flare in the tapered aperture varying as the fourth power of the length of the antenna, and extending in length to at least two thirds of the length of the antenna proper. The term "antenna proper" signifies that structural entity involving the flared opening at one end and a termination at the other end which is separate and distinct from a coaxial or waveguide feed line. The width of the flared opening at a given position can be calculated as the cut out portion W_1 of the sectional perimeter occurring at this position. The length of this cut out portion W_1 relative to the perimeter will then vary directly as the fourth power of the length l_0 of the antenna proper.

The width W_1 at any distance l_1 from the effective closed end of the waveguide antenna seen in FIGS. 7 and 8, should be related to the circumference W_0 of the waveguide tube, the length of the "antenna proper" l_0 , as follows:

$$W_1 = \frac{l_1^4}{l_0^4} W_0$$

This equation is valid only from the point at which the tapered aperture begins; i.e., when l_1 does not extend to the termination point 42 of the tapered aperture the equation is invalid.

Naturally, other rates of flare and other waveguide contours may be used to provide varying characteristics relative to the design requirements. Protuberances 40 as shown in FIG. 9, may be used to improve the dispersion pattern for specific applications where uniform radiation intensity is required over large areas and where pencil beam type radiation would be inadequate at very close ranges. These

protuberances act to reflect energy of sufficient intensity to fill out the voids in the antenna pattern normally occurring at close ranges with narrow beam radiation. The size and placement of these protuberances are most easily located by experimental means.

FIG. 3 shows the cross-section of antenna 31 at a point remote from the terminal opening 30 and, depicts the curve surface 36 which is located opposite the tapered aperture 32. FIG. 4 shows the continuous tubular cross-section of the microwave antenna 31 at a point beyond the section having a tapered aperture located therein.

FIGS. 5 and 6 illustrate graphically the dispersion pattern for microwave energy passing through the opening comprised of the terminal opening 30 and tapered aperture 32 extending therefrom. In FIG. 5 the dispersion pattern in the horizontal plane is shown as detail 34 while in FIG. 6 the dispersion pattern in the vertical plane is shown as detail 35.

I claim:

1. A microwave waveguide antenna comprising an elongated tubular pipe closed at one end and open at the opposite end, a focusing system adjacent the open end and comprising a single tapered axially extending aperture of a length at least one-half the length of the pipe, and a feed located adjacent the closed end of the pipe.

2. A microwave waveguide antenna as recited in claim 1 wherein the tubular pipe is elliptical in cross section.

3. A microwave waveguide antenna as recited in claim 1 wherein the tapered aperture is configured to have its greatest transverse dimension adjacent the open end of the tubular pipe and its minimum transverse width dimension at a location intermediate the ends of said tubular pipe.

4. A microwave waveguide antenna as recited in claim 1 wherein the inner surface of the pipe opposite the tapered aperture of the focusing system is curved.

5. A microwave waveguide antenna as recited in claim 1 further comprising a protuberance located on the inner surface of the tubular pipe opposite the tapered aperture of the focusing system.

6. A microwave waveguide antenna as recited in claim 1 wherein the longitudinally extending edges of the tapered aperture flare concavely from a location intermediate the ends of the tubular pipe to the open end of said tubular pipe.

References Cited

FOREIGN PATENTS

590,651 7/1947 Great Britain.
878,830 11/1942 France.

50 ELI LIEBERMAN, *Primary Examiner*.

U.S. Cl. X.R.

343—767