

MINI COMPONENT SYSTEM CRX-E400

CDX-E400

SERVICE MANUAL

The CRX-E400 is composed of the RX-E400 and the CDX-E400. This service manual is for the CDX-E400. For the RX-E400 service manual, please refer to the following publication number :

RX-E400 100809

For the system operation, please refer to the service manual for the RX-E400.

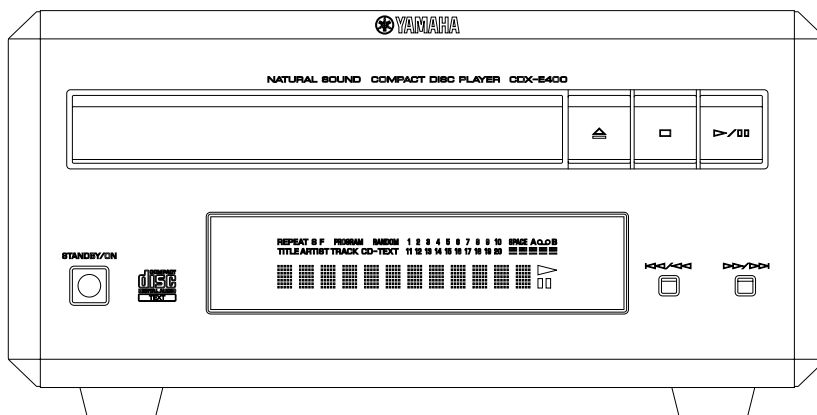

IMPORTANT NOTICE

This manual has been provided for the use of authorized YAMAHA Retailers and their service personnel. It has been assumed that basic service procedures inherent to the industry, and more specifically YAMAHA Products, are already known and understood by the users, and have therefore not been restated.

WARNING: Failure to follow appropriate service and safety procedures when servicing this product may result in personal injury, destruction of expensive components and failure of the product to perform as specified. For these reasons, we advise all YAMAHA product owners that all service required should be performed by an authorized YAMAHA Retailer or the appointed service representative.

IMPORTANT: The presentation or sale of this manual to any individual or firm does not constitute authorization, certification or recognition of any applicable technical capabilities, or establish a principle-agent relationship of any form.

The data provided is believed to be accurate and applicable to the unit(s) indicated on the cover. The research, engineering, and service departments of YAMAHA are continually striving to improve YAMAHA products. Modifications are, therefore, inevitable and specifications are subject to change without notice or obligation to retrofit. Should any discrepancy appear to exist, please contact the distributor's Service Division.

WARNING: Static discharges can destroy expensive components. Discharge any static electricity your body may have accumulated by grounding yourself to the ground buss in the unit (heavy gauge black wires connect to this buss).

IMPORTANT: Turn the unit OFF during disassembly and parts replacement. Recheck all work before you apply power to the unit.

CONTENTS

TO SERVICE PERSONNEL	2-3
PREVENTION OF ELECTRO STATIC DISCHARGE	4
REAR PANELS	4
SPECIFICATIONS	5
INTERNAL VIEW	5
DISASSEMBLY PROCEDURES	6-8
STANDARD OPERATION CHART	9-10
TEST MODE	11-12
ERROR MESSAGE	13-14

IC DATA	15-19
DISPLAY DATA	20
BLOCK DIAGRAM	21
PRINTED CIRCUIT BOARD	22-23
IC BLOCK	24
PIN CONNECTION DIAGRAM	24
SCHEMATIC DIAGRAM	25
PARTS LIST	27-34
PARTS LIST FOR CARBON RESISTORS	35



このサービスマニュアルは、エコマーク認定の再生紙を使用しています。
This Service Manual uses recycled paper.

100808

 **YAMAHA**
YAMAHA CORPORATION
P.O.Box 1, Hamamatsu, Japan

CDX-E400

■ TO SERVICE PERSONNEL

1. Critical Components Information

Components having special characteristics are marked  and must be replaced with parts having specifications equal to those originally installed.

2. Leakage Current Measurement (For 120V Models Only)

When service has been completed, it is imperative to verify that all exposed conductive surfaces are properly insulated from supply circuits.

- Meter impedance should be equivalent to 1500 ohm shunted by 0.15 μ F.
- Leakage current must not exceed 0.5mA.
- Be sure to test for leakage with the AC plug in both polarities.

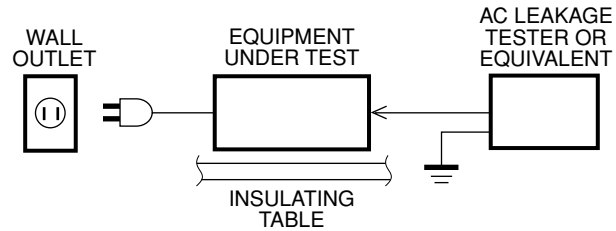

THIS PRODUCT SHOULD NOT BE ADJUSTED OR REPAIRED BY ANYONE EXCEPT PROPERLY QUALIFIED SERVICE PERSONNEL.

WARNING: CHEMICAL CONTENT NOTICE!

The solder used in the production of this product contains LEAD. In addition, other electrical/electronic and/or plastic (where applicable) components may also contain traces of chemicals found by the California Health and Welfare Agency (and possibly other entities) to cause cancer and/or birth defects or other reproductive harm.

DO NOT PLACE SOLDER, ELECTRICAL/ELECTRONIC OR PLASTIC COMPONENTS IN YOUR MOUTH FOR ANY REASON WHATSOEVER!

Avoid prolonged, unprotected contact between solder and your skin! When soldering, do not inhale solder fumes or expose eyes to solder/flux vapor!

If you come in contact with solder or components located inside the enclosure of this product, wash your hands before handling food.

WARNING: Laser Safety

This product contains a laser beam component. This component may emit invisible, as well as visible radiation, which may cause eye damage. To protect your eyes and skin from laser radiation, the following precautions must be used during servicing of the unit.

- 1) When testing and/or repairing any component within the product, keep your eyes and skin more than 30 cm away from the laser pick-up unit at all times. Do not stare at the laser beam at any time.
- 2) Do not attempt to readjust, disassemble or repair the laser pick-up, unless noted elsewhere in this manual.
- 3) CAUTION : Use of controls, adjustments or performance of procedures other than those specified herein may result in hazardous radiation exposure.

Laser Emitting conditions:

- 1) When the Top Cover is removed, and the "STANDBY/ON" SW is turned to the "ON" position, the laser component will emit a beam for several seconds to detect if a disc is present. During this time (5-10 sec.) the laser may radiate through the lens of the laser pick-up unit. Do not attempt any servicing during this period!
If no disc is detected, the laser will stop emitting the beam. When a disc is set, you will not be exposed to any laser emissions.
- 2) The laser power level can be adjusted with the VR on the pick-up PWB. However, this level has been set by the factory prior to shipping from the factory. Do not adjust this laser level control unless instruction is provided elsewhere in this manual. Adjustment of this control can increase the laser emission level from the device.

Laser Diode Properties

- Material : GaAlAs
- Wavelength : 780 nm
- Emission Duration : Continuous
- Laser Output : max. 44.6 μ W*

* This output is the value measured at a distance of about 200 mm from the objective lens surface on the Optical Pick-up Block.

When checking the laser diode emission, keep your eyes more than 30 cm away from the objective lens.

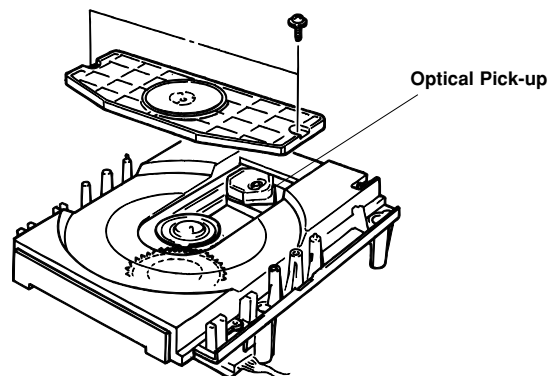

VARO! : AVATTAESSA JA SUOJALUKITUS OHITETTAESSA OLET ALTTIINA NÄKYMÄTTÖMÄLLE LASER-SÄTEILYLLE. ÄLÄ KATSO SÄTEESEEN.

WARNING! : OSYNLIG LASERSTRÅLNING NÄR DENNA DEL ÄR ÖPPNAD OCH SPÄRREN ÄR URKOPPLAD. BETRAKTA EJ STRÅLEN.

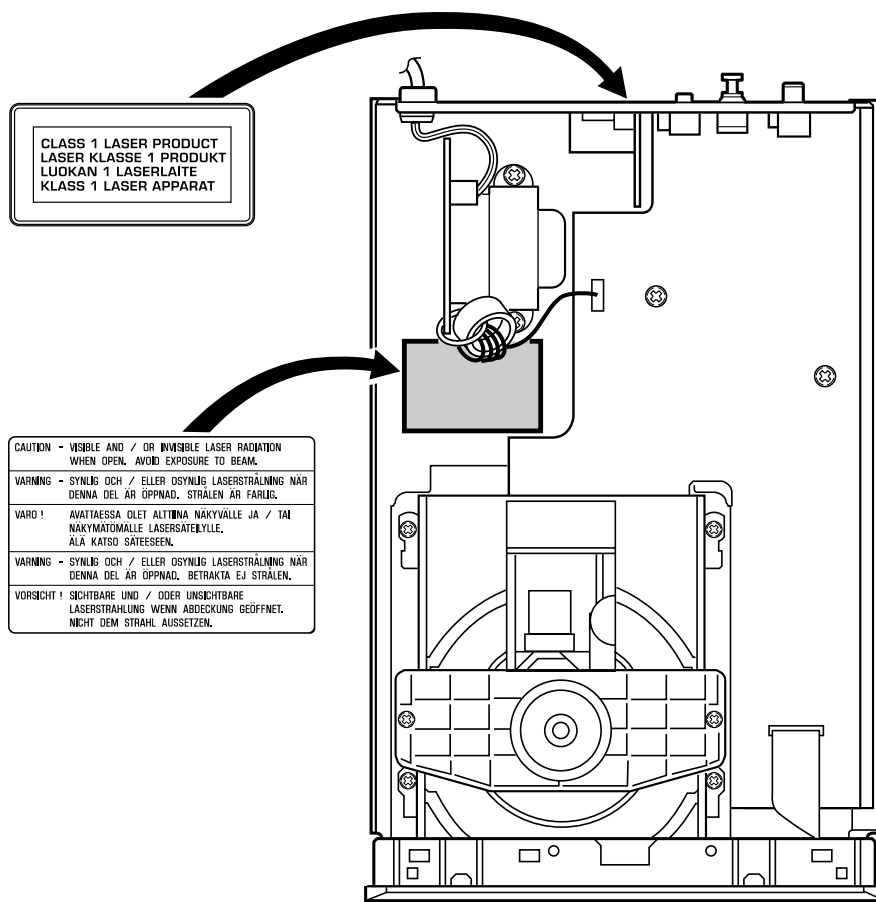

■ PREVENTION OF ELECTRO STATIC DISCHARGE

The laser diode in the CD mechanism unit (optical pickup) may be damaged due to static electricity from clothes or the human body. Use caution to prevent electrostatic damage when servicing or handling the laser diode.

1. Grounding for electrostatic damage prevention

1. Worktable grounding
Put a grounded conductive material (sheet) or iron sheet on the area where the optical pickup is placed.
2. Human body grounding
Use an anti-static wrist strap to discharge the static electricity from your body.

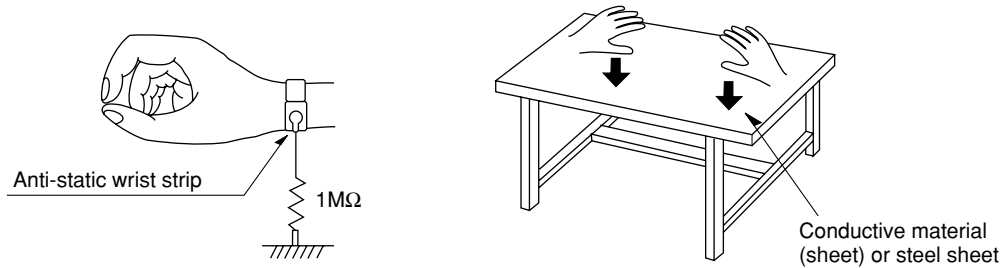

2. Handling of the optical pickup

Do not use a tester to check the laser diode in the optical pickup. The power supply in the tester will damage the laser diode.

3. Handling Precautions for the CD mechanism Unit (Optical Pickup)

1. Handle the CD mechanism unit (optical pickup) gently, as it is an extremely high-precision assembly.
2. The flexible cable lines may break if an excessive force is applied to it. Use caution when handling the cable.
3. The semi-fixed resistor for laser power adjustment should not be adjusted. Do not turn the resistor.

■ REAR PANELS

▼ R model

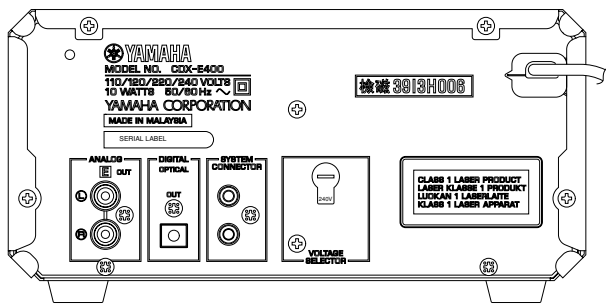

▼ B model

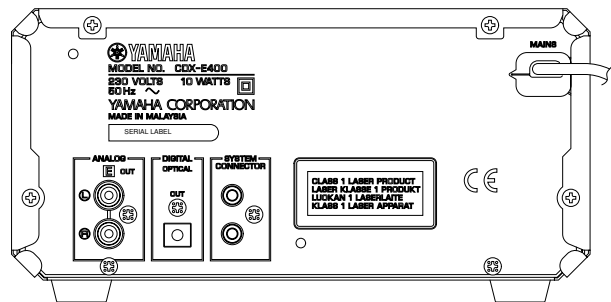

▼ G model

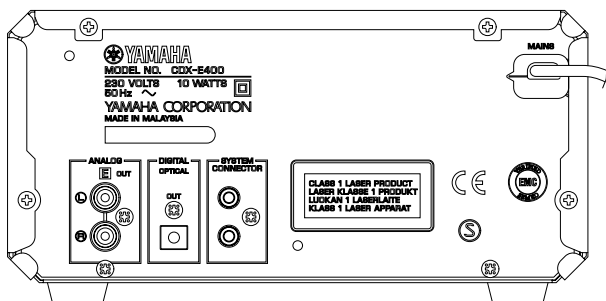

CDX-E400

■ SPECIFICATIONS

Output Level 1kHz, 0dB	2.0 ± 0.5Vrms
Signal to Noise Ratio (EIAJ)	102dB
Dynamic Range	95dB
Harmonic Distortion+Noise (1kHz)	0.004%
Frequency Response 2Hz — 20kHz	±0.5dB
Power Requirements	
B, G models	230V AC 50Hz
R model	110/120/220/240V AC 50/60Hz
Power Consumption	10W
Dimensions (W x H x D)	217 x 108 x 346mm (8-9/16" x 4-1/4" x 13-5/8")
Weight	3.0kg (6 lbs 9 oz)
Finish	
Gold color	R, G models
Silver color	G, B models

*Specifications are subject to change without notice.

B **British model**
G **European model**
R **General model**

● DIMENSIONS

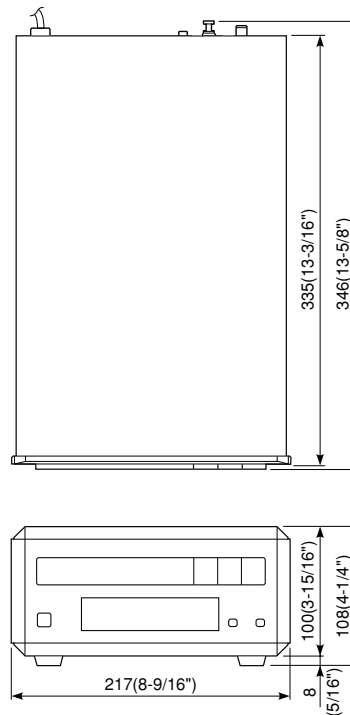

Unit : mm (inch)

■ INTERNAL VIEW

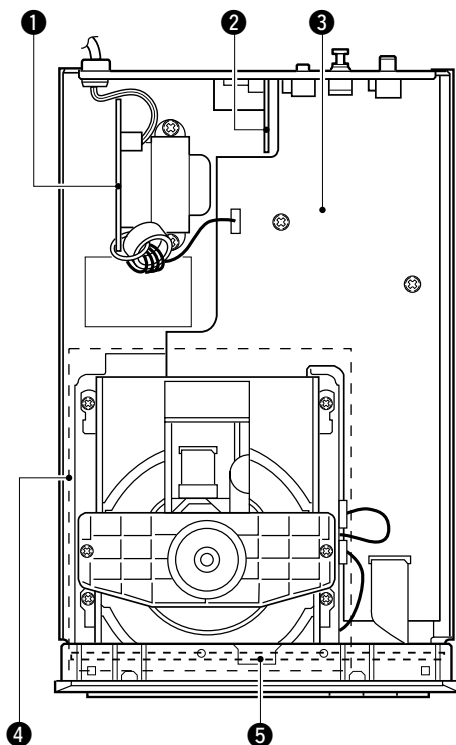

- ① MAIN (3) P.C.B.
- ② MAIN (4) P.C.B. (R model only)
- ③ MAIN (1) P.C.B.
- ④ CD MECHANISM UNIT
- ⑤ MAIN (2) P.C.B.

■ DISASSEMBLY PROCEDURES (Remove parts in disassembly order as numbered.)

1. Removal of Top Cover

- Remove 4 screws (①) and 4 screws (②) in Fig. 1.
- Lift the Top Cover at the rear and move it rear-ward slantingly.

2. Removal of Front Panel

- Remove a connector (CB102) in Fig. 2.
- Remove 2 screws (③) and 2 screws (④) in Fig. 1.
- Remove 2 hooks and then pull the Front Panel forward.

3. Removal of CD Mechanism Unit

- Remove a connector (CB1) in Fig. 2.
- Remove W2 and W3 from the CD Mechanism in Fig. 2.
- Remove 4 screws (⑤) in Fig. 1.
- Remove the CD Mechanism Unit in Fig. 1.

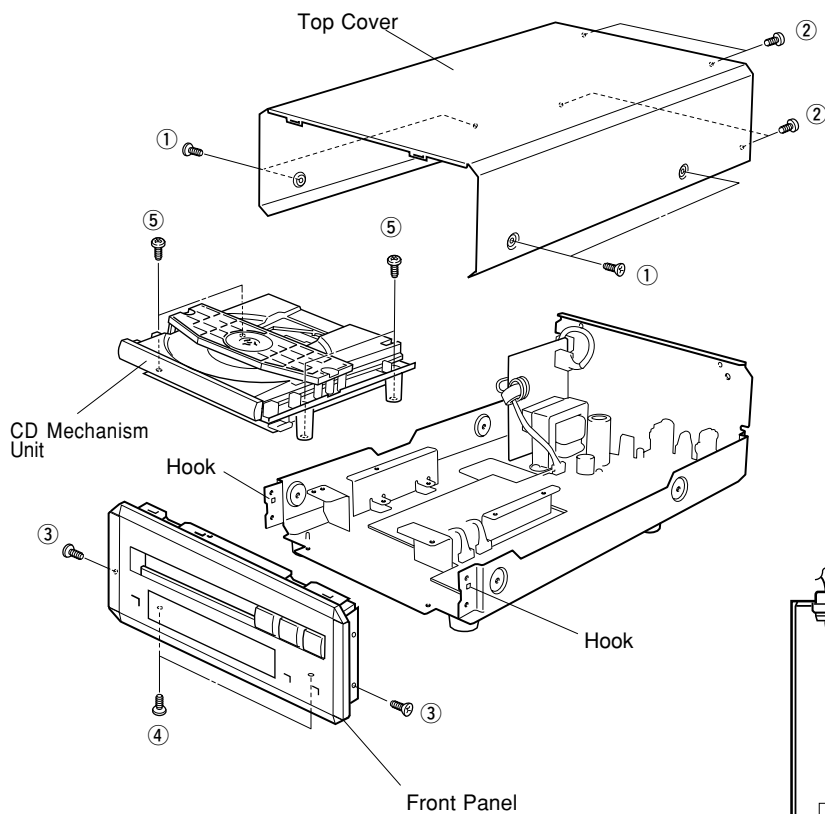

Fig. 1

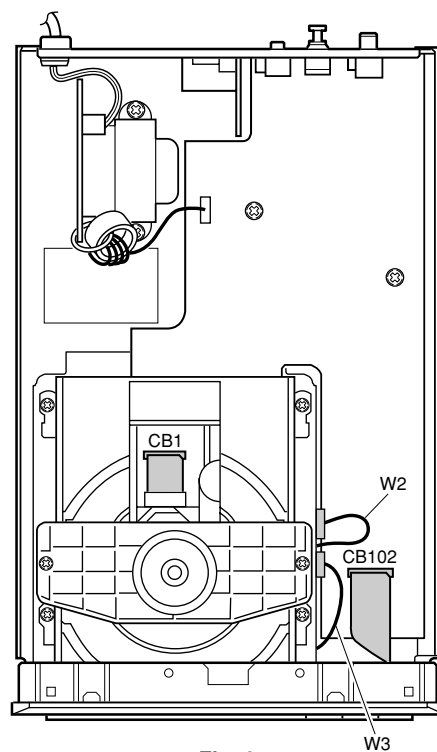

Fig. 2

● Servicing Position

- a. Remove the Top Cover, Front Panel and CD Mechanism Unit.
- b. Remove 3 screws (⑥) and 2 screws (⑦) in Fig. 3.
- c. Loosen the style pin (PN1) to set W401 free in Fig. 3.
- d. With the rear panel attached, remove the Main P.C.B.
- e. With the rear panel attached, set the Main P.C.B. on its side as shown in Fig. 4.
At this time, fit the cut in the rear panel with the main chassis as shown in Fig. 4.
- f. Replace the PU cable of the CD Mechanism with the below specified extension cable.
Extension cable
16P 230 mm: V3340500
- g. Install the CD Mechanism to the frame mechanism.
- h. Connect CB1 as shown in Fig. 5.
- i. Connect W2 and W3 to the CD Mechanism as shown in Fig. 6.
- j. Place the front panel on the base as shown in Fig. 6.
Base height: 10cm
- k. Connect CB102 as shown in Fig. 6.
- l. Connect the power cable, turn on the power and check for operation.

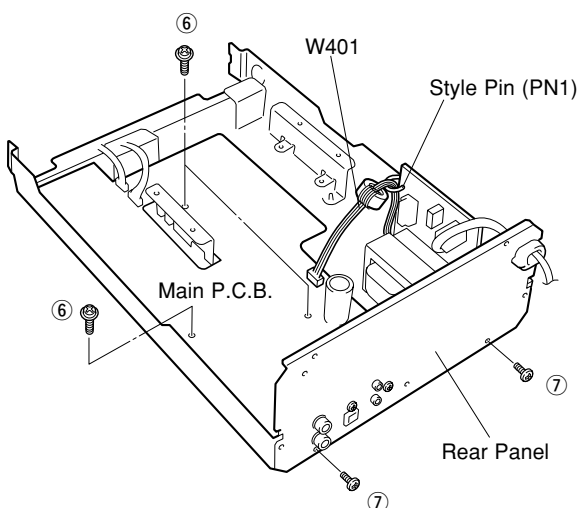

Fig. 3

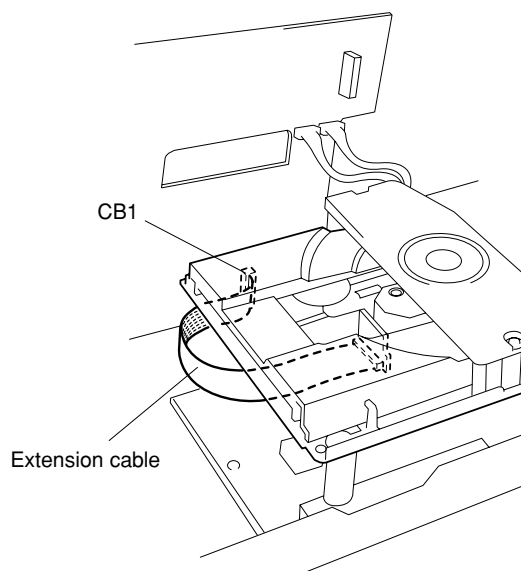

Fig. 5

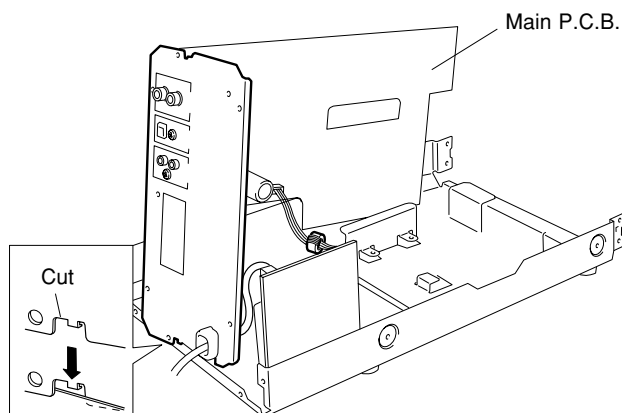

Fig. 4

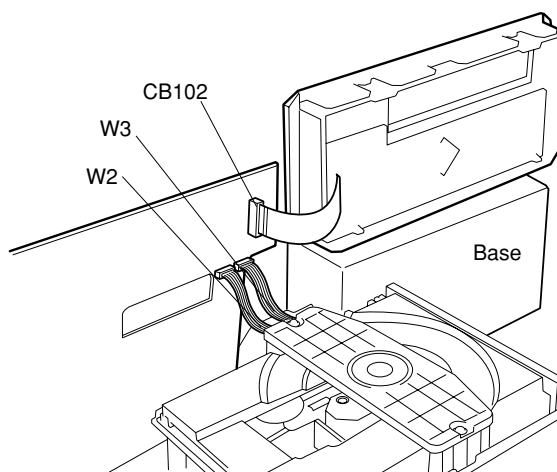

Fig. 6

4. Removal of Tray Unit

- a. Remove 2 screws (⑧) and then remove the Chucking Unit in Fig. 7.
- b. Remove 1 hook and then remove the Stopper Pin in Fig. 7.
- c. Rotate the Drive Gear and then open the Tray Unit in Fig. 7.
- d. Detach the Stoppers on both sides and then pull out the Tray in Fig. 7.

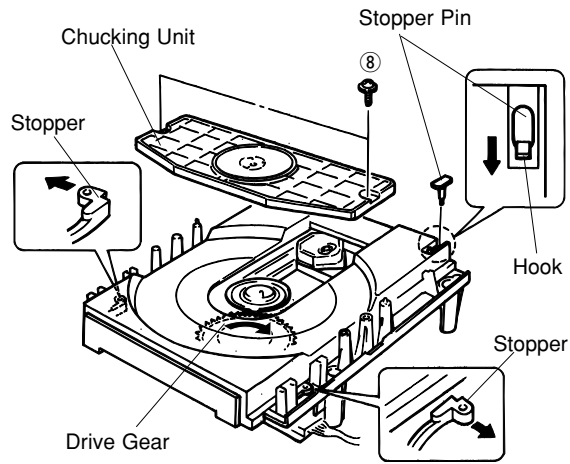

Fig. 7

5. Removal of Pick-up Head

- a. Remove 2 screws (⑨) in Fig. 8.
- b. Remove a pick-up cable in Fig. 8.
- c. Remove 4 screws (⑩) and then remove the Drive Unit in Fig. 8.
- d. Remove the gear A in Fig. 9.
- e. Pull out the Sled Shaft in Fig. 9.
- f. Remove the Pick-up Head.

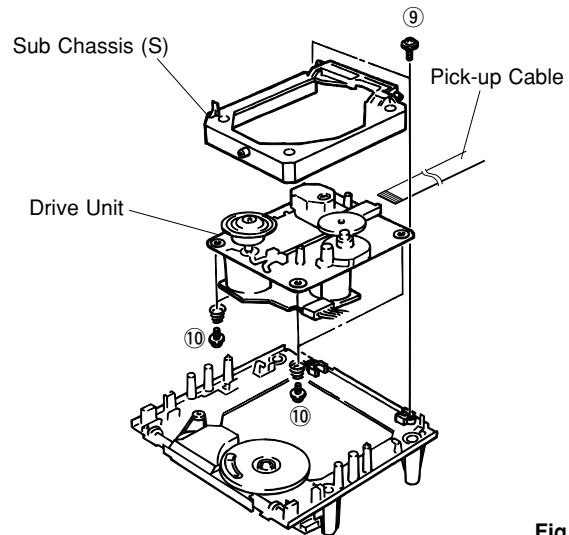

Fig. 8

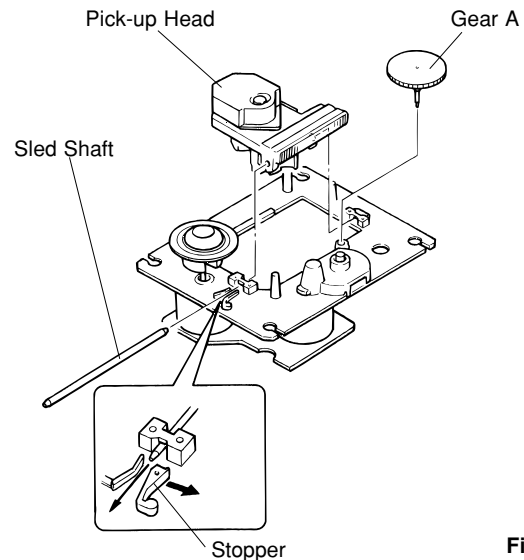
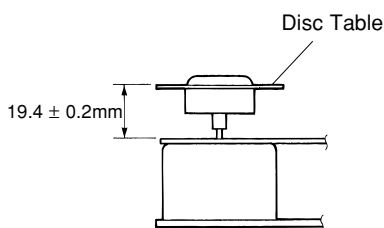
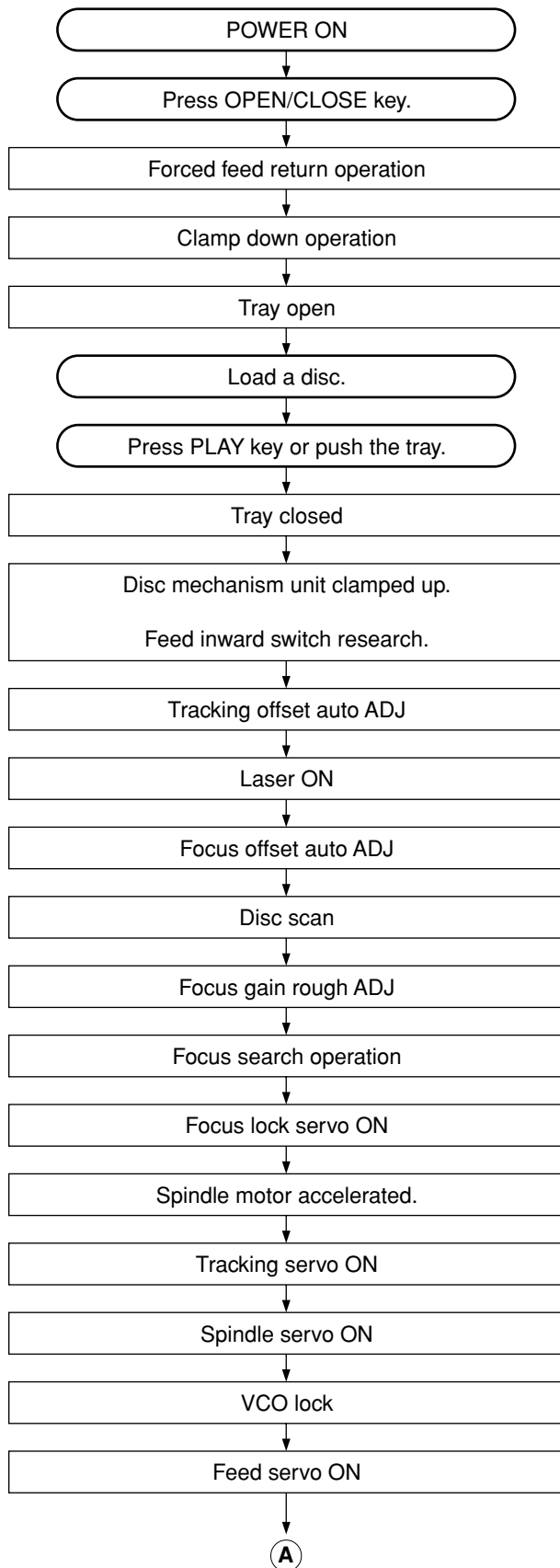

Fig. 9

Check that the disc table height is as specified below.



■ STANDARD OPERATION CHART



If a disc is not loaded, “-:-” appears in the time indicator.

“ OPEN ” appears in the indicator.

“TRV” signal is output until detection of LIMIT switch.

Stop after detection of LOADING switch.

Proceeds to next step after detection of LOADING switch.

if FLSW = L, (IC103, 21 pin)
Proceeds To Next Step.

LSON = “L” (IC101, 2 pin)

$\overline{\text{FLOCK}}$ = “H” → “L” (IC102, 11 pin)

$\overline{\text{TLOCK}}$ = “H” → “L” (IC102, 12 pin)

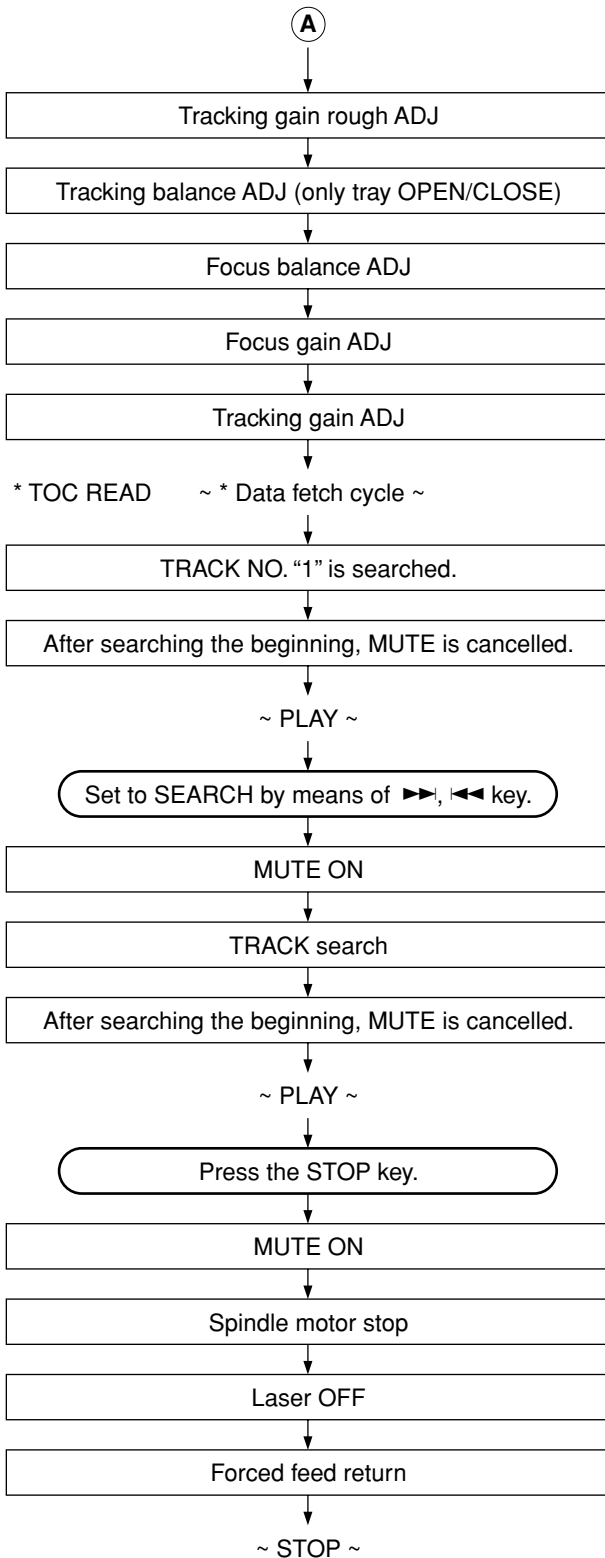

: MUTE OFF = "H" → "L" (Q7 Collector)
 "0:00" appears in the time indicator.

: MUTE ON = "L" → "H" (Q7 Collector)

: MUTE OFF = "H" → "L" (Q7 Collector)
 "0:00" appears in the time indicator.

: MUTE ON = "L" → "H" (Q7 Collector)

: LSOFF = "L" → "H" (IC101, 2 pin)

: FLSW (IC103, 21 pin) = "L"

CDX-E400

■ TEST MODE

When the power off, press the “STANDBY/ON” key while pressing the “□” key and the “▷/00” key and then release your fingers from those keys.

Note: At this time, “□” key must be pressed before “▷/00” key is pressed. Otherwise “▷/00” key operation causes product mode.

When the test mode started, the following messages are displayed.

After a second

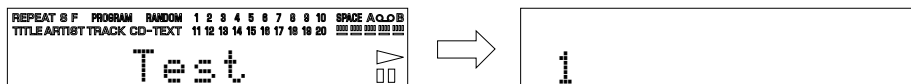

● Test Mode Function List of Panel keys

PANEL KEY	FUNCTION
 (OPEN/CLOSE)	Execute the test command selected with the SKIP/SEARCH keys
 (PLAY/PAUSE)	Plays if focus servo is effective. TRON, MUTE OFF.
 (STOP)	All stop. (Focus, spindle, feed, laser, tray, etc.) Initializes FL display
 (SKIP/SEARCH)	Decrement the test command number.
 (SKIP/SEARCH)	Increment the test command number.

Sample of display of test command

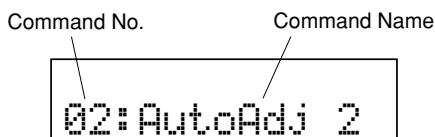

The functions corresponded to the test command numbers are as follows.

Command No.	Command Name	FUNCTION
00	Op/Cl	Tray open/close.
01	AutoAdj 1	Auto adjustment mode 1 (TR-off set, FO-off set, FO-rough gain adjustment)
02	AutoAdj 2	Auto adjustment mode 2 (TR-balance, TR-rough gain adjustment)
03	AutoAdj 3	Auto adjustment mode 3 (FO-fine gain, TR-fine gain, FO-balance adjustment)
04	TV Rev	Move traverse reverse till the inner SW turn on.
05	TV Fwd	Move traverse forward.
06	TV Stop	Stop traverse.
07	SP Accel	Accelerate spindle.
08	SP Brake	Decelerate spindle.
09	SP SV.On	Spindle servo on.
10	SP SV.Off	Spindle free (servo off)
11	SP Stop	Stop spindle.
12	FO Search	FOON, TROF (Enter focus search if focus servo is off.)
13	TR,TV Off	FOON, TROF, TVOF(FEOF) (Enter focus search if focus servo is off.)
14	1Kick Rev	Reverse 1 track kick continuously.
15	1Kick Fwd	Forward 1 track kick continuously.
16	10 K. Rev	Reverse 10 tracks kick continuously.
17	10 K. Fwd	Forward 10 tracks kick continuously.
18	30 K. Rev	Reverse 30 tracks kick continuously.
19	30 K. Fwd	Forward 30 tracks kick continuously.

Command No.	Command Name	FUNCTION
20	150K. Rev	Reverse 150 tracks kick continuously.
21	150K. Fwd	Forward 150 tracks kick continuously.
22	PrdctMode	Returns to product mode.
23	Error Msg	Display the latest error message. (see page 13)
24	Test Eep	Check EEPROM. (Mute on if test OK. Mute off if test NG)
25	Check FL	Check FL display. (see page 12)
26	Flick/Tick	To trigger Focus lock and Track lock during play
27	S/W Vers	To display current version of software

Test mode function List of Remote Controller keys

System Control Code	KEY	FUNCTION
80	□	All stop. (Focus, spindle, traverse, laser, tray, etc.)
81	▷/□□	PLAY (FOON, TRON, TVON(FEON), SPON)
83	▷▷ ▷▷	Move traverse forward.
84	◁◁ ◁◁	Move traverse reverse till the inner SW turn on.
88	RANDOM	SPON (Spindle servo on.)
89	TEXT/TIME	Check FL display.
8A	PROG	Accelerate spindle.
8B	REP	FOON, TROF (Enter focus search if focus servo is off.)
8C	TAPE	Spindle free (servo off)
90	0	Forward 150 tracks kick continuously. (Coefficient set up mode : lower digit up)
91	1	Returns to product mode.
92	2	Auto adjustment mode 1 (TR-off set, FO-off set, FO-rough gain adjustment)
93	3	Auto adjustment mode 2 (TR-balance, TR-rough gain adjustment)
94	4	Auto adjustment mode 3 (FO-fine gain, TR-fine gain, FO-balance adjustment)
95	5	Reverse 1 track kick continuously. (Coefficient set up mode : address down)
96	6	Forward 1 track kick continuously. (Coefficient set up mode : address up)
97	7	Reverse 30 tracks kick continuously. (Coefficient set up mode : upper digit down)
98	8	Forward 30 tracks kick continuously. (Coefficient set up mode : upper digit up)
99	9	Reverse 150 tracks kick continuously.(Coefficient set up mode : lower digit down)
9A	+10	Change the coefficient mode. (→Conefficient set up mode→Return to product mode with set up coefficient)

Note : Check FL display

Each time the key pressed, the display changes as follows (①→②→.....→⑨)

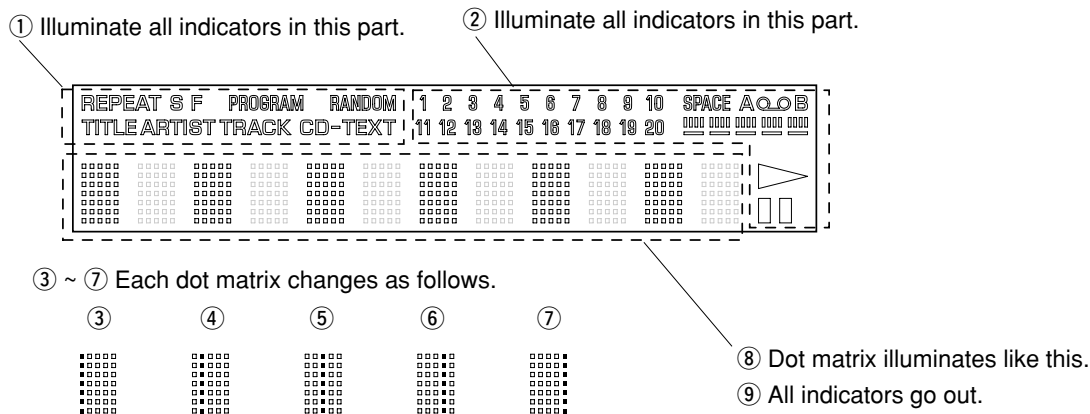

■ ERROR MESSAGE

- If stopped by any cause, error message can be displayed by pressing the remote STOP key while pressing and holding the panel STOP key, or by test mode command number 23.
The player holds the latest error message in EEPROM. So even if stopped with no error, the latest error message can be displayed with same operation.
- Shown below is an example of display. ("E-73" as an example)

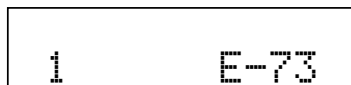

- Listed in the table below are error messages.

● Error Messages List

ERROR MESSAGES	DESCRIPTION
E - X 0	Data cannot be read after finishing search.
E - X 1	Data cannot be read during PLAY(X=0), PAUSE(X=3), or SCAN(X=2).
E - 7 1	At the start, tracking servo is not effective.
E - 7 2	At the start, spindle servo PLL is not effective.
E - 7 3	At the start, data can not be read.
E - 7 5	Tracking servo off in FO balance, or FO fine, or TR fine gain adjustment and recovery action failure.
E - 9 4	Close switch does not work with tray closed.
E - 9 5	Open switch does not work with tray open.
E - X 7	Traverse(Feed) inner switch does not work.
E - X 8	Recovery action fails after focus drop.
ERROR	MN35511 does not give response of SENSE, with resetting by the unit's microcomputer.

***No. for each state (meaning of "X")**

PLAY X="0"
 SCAN X="2"
 PAUSE X="3"
 PEAK SEARCH X="4"
 SEARCH X="5"
 START X="7"
 STOP X="8"
 LOADING X="9"
 OPEN X="—" (dash)
 NO DISC X="C"

1) Error Code Troubleshooting

Error code **X0**, **X1**, **73** Data cannot be read.

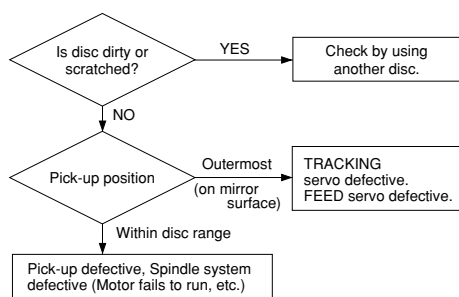

Error codes **94**, **95** Poor tray loading operation.

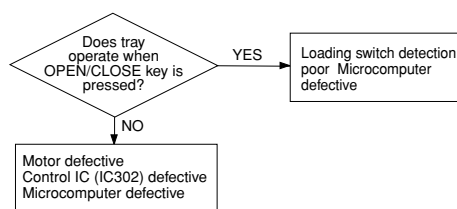

Error code **X7** FEED operation defective. (Limit switch fails)

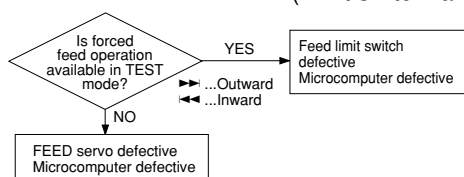

Error code **X8** Focus drops.

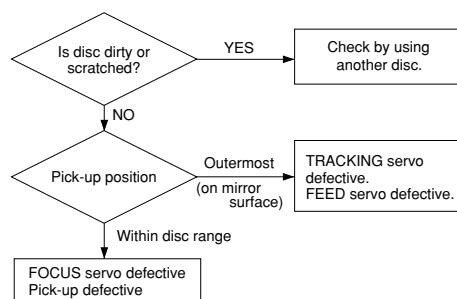

2) Troubleshooting from System Malfunctions

a) Tray fails to come out/go in.

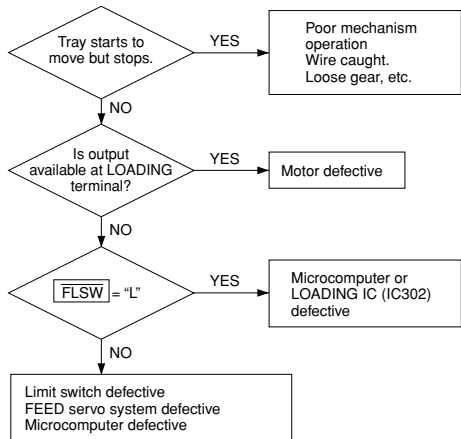

When tray fails to close completely (when it stops midway)

[Corrective measure]

- 1) Turn ON the power and open the tray.
- * If it failed to open (head and tray contacting each other), open it after removing the chucking unit.
- 2) Turn OFF the power and force the tray to go in fully and close.
- 3) With the power turned ON, open and close the tray to check if the tray close completely.

b) No sound generated, Sound cut during play. (but time display advances properly)

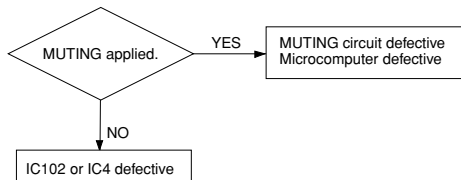

c) Operates as if no disc loaded. (although loaded)

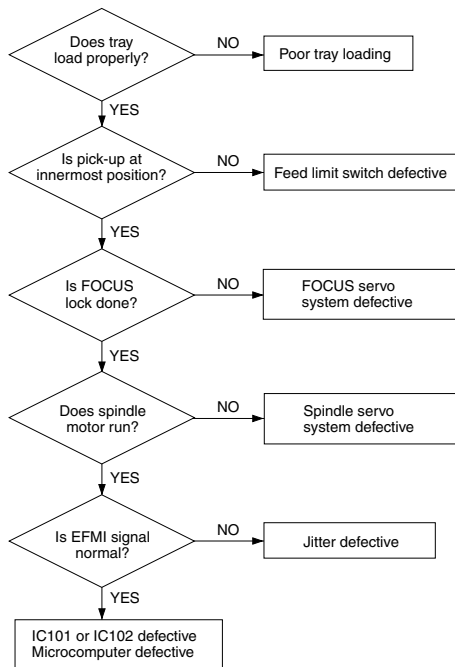

d) Sound skips. (Time display fails to advance properly)

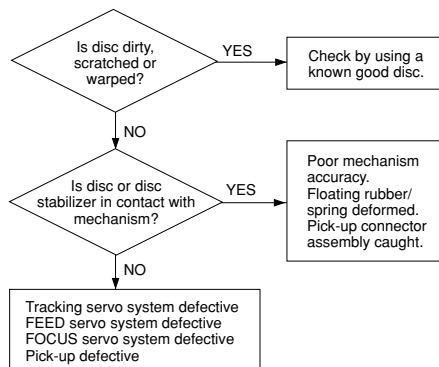

e) No search provided. (Sound skipped after search)

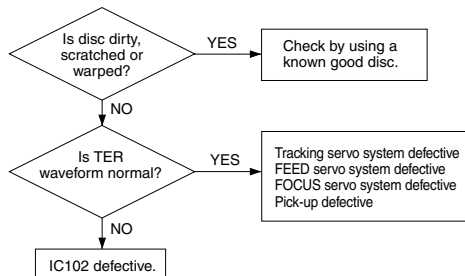

CDX-E400

IC DATA

IC103 : μPD78076GF-108-3BA
8bit μ-COM

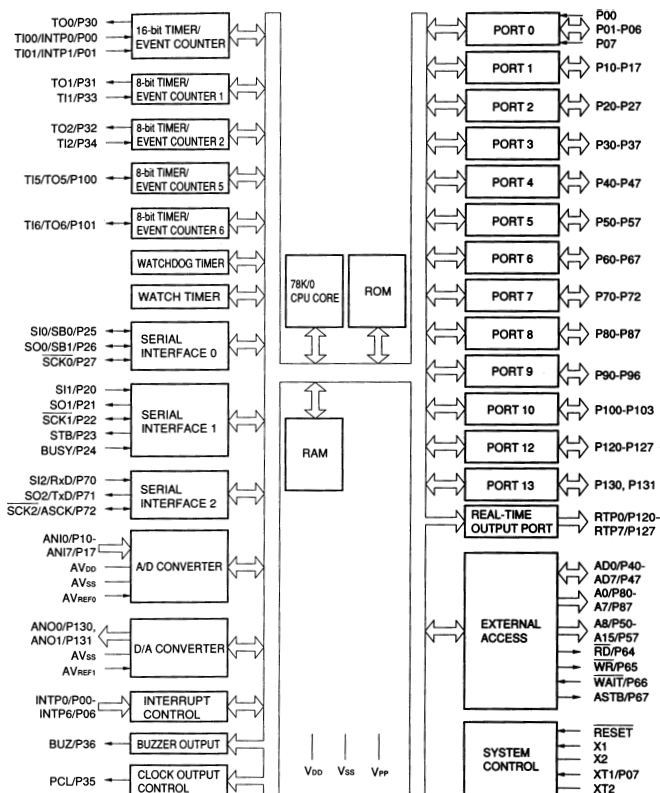
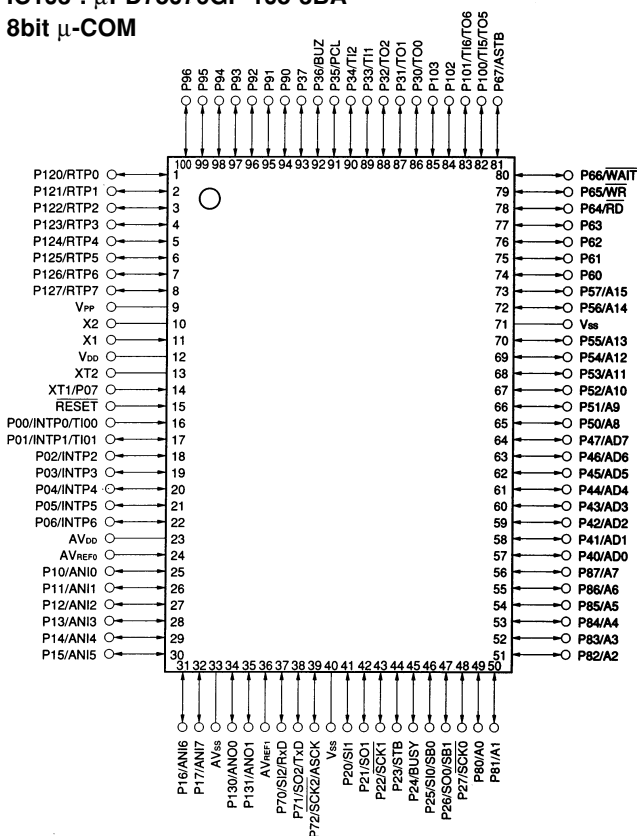

No.	Port	Name	I/O	Function
1	P120/RTP0	OPSW	I	Opened state of tray sensing switch input. Opened state at "L".
2	P121/RTP1	CLSW	I	Closed state of tray sensing switch input. Closed state at "L".
3	P122/RTP2			N.C.
4	P123/RTP3	MUTE	O	Sound output at "H" and sound output muted at "L".
5	P124/RTP4	RST	O	Hardware reset output of MN35511. Reset at "L".
6	P125/RTP5	DMUTE	O	Mute output to MN35511. Muted at "H".
7	P126/RTP6	TLOCK	I	Tracking servo drawing signal input from MN35511. Drawn at "L".
8	P127/RTP7	FLOCK	I	Focus servo drawing signal input from MN35511. Drawn at "L".
9	IC	IC		GND
10	X2	X2		Ceramic oscillator. (5MHz)
11	X1	X1		
12	VDD	VDD		
13	XT2	XT2		N.C.
14	XT1/P07	XT1		GND
15	RESET	RESET	I	Reset input.
16	P00/INTP0/T100	REM	I	Pull down
17	P01/INTP1/T101	BLKCK	I	Sub code, block clock input from MN35511.
18	P02/INTP2	LED		N.C.
19	P03/INTP3	SYSIN	I	System control input.
20	P04/INTP4	SYSOUT	O	System control output.
21	P05/INTP5	FLSW	I	Feed origin switch input. Feed origin at "L".
22	P06/INTP6	CLDCK	I	MN35511 subcode frame clock
23	AVDD	AVDD		+5V
24	AVREF0	AVREF0		+5V
25	P10/ANI0			N.C.
26	P11/ANI1			N.C.
27	P12/ANI2			N.C.

CDX-E400

IC103 : μ PD78076GF-108-3BA
8bit μ -COM

No.	Port	Name	I/O	Function
28	P13/ANI3			N.C.
29	P14/ANI4	SDA	I/O	DATA port for EEPROM.
30	P15/ANI5	SCL	I/O	DATA CLOCK for EEPROM.
31	P16/ANI6			N.C.
32	P17/ANI7	LDRCTL	O	Laser ON control
33	AVSS	AVSS		GND
34	P130/ANO0	OP/CL	O	N.C.
35	P131/ANO1	GCTRL	O	Gain and APC control
36	AVREF1			+5V
37	P70/S12/RXD	SUBQ	I	Serial I/F input (SUBQ)
38	P71/SO2/TXD	STAT	I	Status signal input from MN35511.
39	P72/SCK2/ASCK	SQCK	O	Serial I/F clock (SQCK)
40	VSS	VSS		GND
41	P20/SI1	SUBC	I	Serial I/F input (CD TEXT)
42	P21/SO1			N.C.
43	P22/SCK1	SBCK2	O	Serial I/F clock (CD TEXT)
44	P23/STB	MLD	O	MN35511 chip select
45	P24/BUSY	SENSE	I	MN35511 sense input
46	P25/SI0/SB0	SO		N.C.
47	P26/SO0/SB1	MDATA	O	Serial I/F output (MDATA/FL driver/EEPROM)
48	P27/SCK0	MCLK	O	Serial I/F clock (MCLK/FL driver/EEPROM)
49	P80/A0	CS		N.C.
50	P81/A1	CE	O	FL driver chip select
51	P82/A2	FLCE	O	FL driver reset
52	P83/A3			N.C.
53	P84/A4			N.C.
54	P85/A5	FEOF	O	Feed servo off signal output.
55	P86/A6			N.C.
56	P87/A7			
57	P40/AD0			
58	P41/AD1			
59	P42/AD2			
60	P43/AD3			
61	P44/AD4			
62	P45/AD5			
63	P46/AD6			
64	P47/AD7			
65	P50/A8	KD4		
66	P51/A9	KD3		
67	P52/A10	KD2		
68	P53/A11	KD1	O] Key scan
69	P54/A12	KD0	O	
70	P55/A13			N.C.
71	VSS	VSS		GND
72	P56/A14			N.C.
73	P57/A15			
74	P60	K4		
75	P61	K3] Key detect
76	P62	K0	I	
77	P63	K1	I	
78	P64/RD	K2	I	
79	P65/WR			N.C.
80	P66/WAIT			Pull down

CDX-E400

IC103 : μ PD78076GF-108-3BA
8bit μ -COM

No.	Port	Name	I/O	Function
81	P67/ASTB			Pull down
82	P100/TI5/TO5			N.C.
83	P101/TI6/TO6			
84	P102			
85	P103			
86	P30/TO0	close	O	
87	P31/TO1	open	O	Tray close signal output
88	P32/TO2			N.C.
89	P33/TI1			
90	P34/TI2			
91	P35/PCL			
92	P36/BUZ			
93	P37	STAN	O	M56748 standby control
94	P90		I	Pull down
95	P91		I	Pull down
96	P92		O	Monitor 1
97	P93		O	Monitor 2
98	P94		O	Monitor 3
99	P95		O	Monitor 4
100	P96		O	Monitor (error)

IC102 : MN35511AL
Signal Processor & Controller

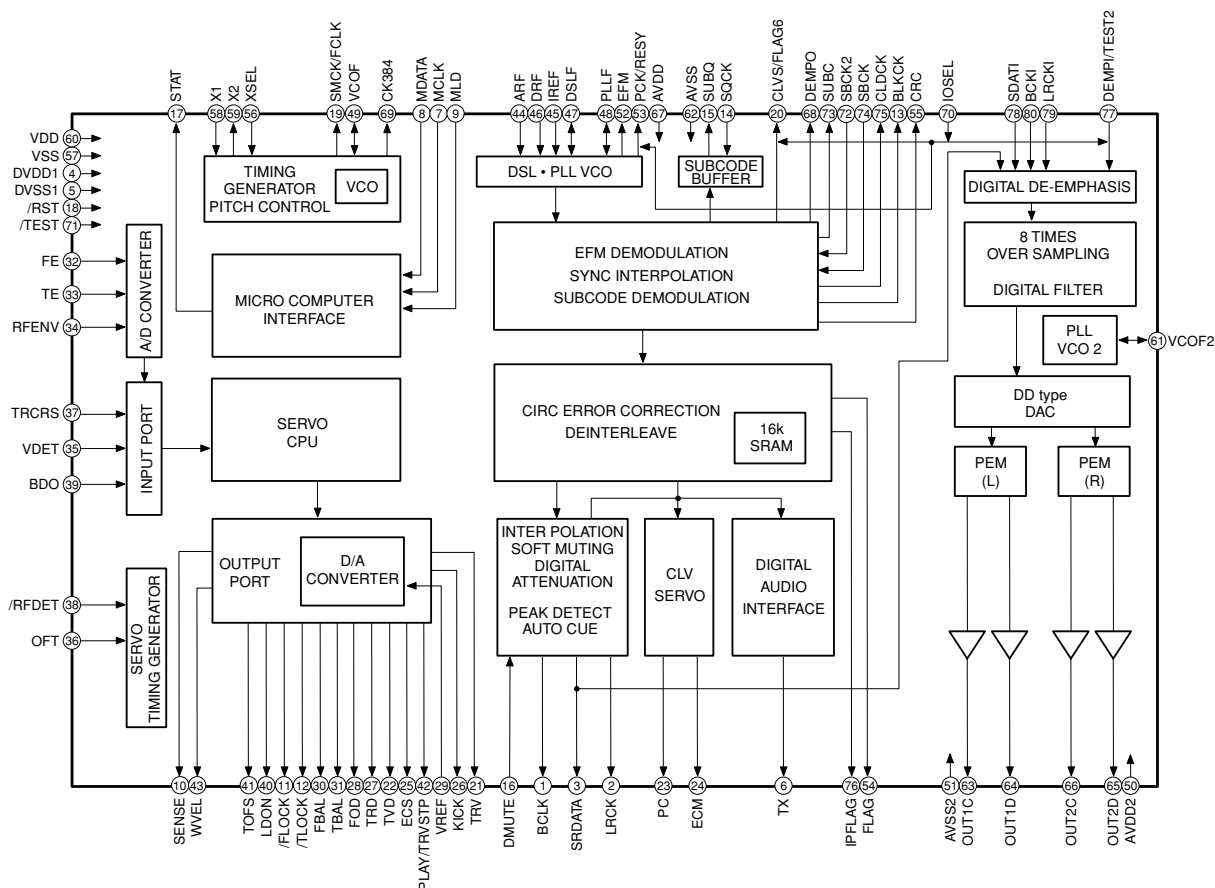

CDX-E400

IC102 : MN35511AL
Signal Processor & Controller

Pin No.	Name	I/O	Function	
1	BCLK	O	Bit clock output for SR DATA	(NC)
2	LRCK	O	L/R identification signal output	(NC)
3	SRDATA	O	Serial data output	(NC)
4	DVDD1	I	Power supply for digital circuit	(+5)
5	DVSS1	I	GND for digital circuit	
6	TX	O	Digital, audio, interface output signal	
7	MCLK	I	Microprocessor command clock signal input (data latched at leading edge)	
8	MDATA	I	Microprocessor command data input	
9	MLD	I	Microprocessor command load signal input (L : LOAD)	
10	SENSE	O	Sense signal output (OFT, FESL, NACEND, NAJEND, SFG, NWTEND)	
11	FLOCK	O	Focus servo drawing signal (L : when drawn)	
12	TLOCK	O	Tracking servo drawing signal (L : when drawn)	
13	BLKCK	O	Sub code block clock signal (BLKCK=75Hz)	
14	SQCK	I	Clock input for sub-code Q register	
15	SUBQ	O	Sub-code Q code output	
16	DMUTE	I	Muting input (H : MUTE)	
17	STAT	O	Status signal (CRC, STCNT, CLVS, TTSTOP, SQOK, RESY, FCLV, FLAG6, SENSE, /FLOCK, /RFDET, /TLOCK)	
18	RST	I	Reset input (L : RESET)	
19	SMCK/ FCLK	O	4.2336MHz clock signal output SMCK when command is defaulted. (Note 1) SMCK (8.4672MHz), FCLK (7.35kHz) or "L" fixed is selected when command is switched.	(NC)
20	CLVS/ FLAG6	O	With command defaulted : CLVS when IOSEL=H, FLAG6 when IOSEL=L These settings can be reversed by command (FLAG6 when IOSEL=H).	(NC)
21	TRV	O	Traverse (Feed) forced feed output	3-State
22	TVD	O	Traverse (Feed) drive output	
23	PC	O	Spindle motor ON signal L : ON (default)	(NC)
24	ECM	O	Spindle motor drive signal (forced mode output)	3-State
25	ECS	O	Spindle motor drive signal (servo error signal output)	
26	KICK	O	Kick pulse output	3-State
27	TRD	O	Tracking drive output	
28	FOD	O	Focus drive output	
29	VREF	I	Reference voltage for DA output block (TVD, ECS, TRD, FOD, FBAL, TBAL)	
30	FBAL	O	Focus balance adjustment output	
31	TBAL	O	Tracking balance adjustment output	
32	FE	I	Focus error signal input (analog input)	
33	TE	I	Tracking error signal input (analog input)	
34	RFENV	I	RF envelope signal input (analog input)	
35	VDET	I	Oscillation detect signal input (H : DETECT)	(GND)
36	OFT	I	Off track signal input (H : OFF TRACK)	
37	TRCRS	I	Track cross signal input (analog input)	
38	RFDET	I	RF detect signal input (L : DETECT)	
39	BDO	I	Drop out signal input (H : DROP OUT)	
40	LDON	O	Laser ON signal output (H : ON)	(NC)
41	TOFS	O	Tracking offset adjustment output	(NC)
42	PLAY/TRVSTOP	O	Switched by command. PLAY (Play signal output) when command is defaulted.	(NC)
43	WVEL	O	Double speed status signal output (H : double speed)	(NC)
44	ARF	I	RF signal input	
45	IREF	I	Reference current input terminal	
46	DRF	I	Bias terminal for DSL	

(Note 1) At the SMCK/FCLK pin, output does not stop while /RST=L.

IC102 : MN35511AL
Signal Processor & Controller

Pin No.	Name	I/O	Function	
47	DSLFL	I/O	Loop filter terminal for DSL	
48	PLLF	I/O	Loop filter terminal for PLL	
49	VCOF	I/O	Loop filter terminal for VCO	(+5)
50	AVDD2	I	Power supply for analog circuit (for AD of DSL, PLL, DA output blocks)	(+5)
51	AVSS2	I	GND for analog circuit (for AD of DSL, PLL, DA output blocks)	(GND)
52	EFM	O	EFM signal output	(NC)
53	PCK/ RESY	O	With command defaulted : PLL extract clock output PCK when IOSEL=H, frame re-synchronous signal RESY when IOSEL=L These settings can be reversed by command (RESY when IOSEL=H).	(NC)
54	FLAG	O	Flag signal output	(NC)
55	CRC	O	Sub-code CRC check result output (H : OK, L : NG)	(NC)
56	XSEL	I	L : Normal mode H : • For internal master clock, VCO2 output clock for jitter adsorbing PLL is used instead of Xtal oscillation output (X2). • VCO2 is always fixed to oscillation mode regardless of VCO2 oscillation stop command or resetting (/RST=L) and Xtal oscillation is stopped.	(GND)
57	VSS	I	GND for oscillation circuit	
58	X1	I	Crystal oscillation circuit input terminal	
59	X2	O	Crystal oscillation circuit output terminal	
60	VDD	I	Power supply for oscillation circuit	(+5)
61	VCOF2	O	PLL loop filter terminal for jitter adsorption	(GND)
62	AVSS1	O	GND for audio DAC	
63	OUT1C	O	PEM output terminal 1C	
64	OUT1D	O	PEM output terminal 1D	
65	OUT2D	O	PEM output terminal 2D	
66	OUT2C	O	PEM output terminal 2C	
67	AVDD1	I	Power supply terminal for audio DAC	
68	DEMPO	O	Deemphasis detect signal output	(NC)
69	CK384	O	384fs clock output (At the CK384 pin, output does not stop while /RST=L.) Xtal system when command is defaulted. Signal processing system when command is switched	(NC)
70	IOSEL	I	Mode selecting terminal	(+5)
71	TEST	I	Test mode setting terminal (Normal : H)	(+5)
72	SBCK2	I	Sub-code data read clock input	
73	SUBC	O	Sub-code serial output (SBCK effective) when command is defaulted. PACK data usable (SBCK2 effective) when command is switched	
74	SBCK	I	Clock input for sub-code serial output (with pull-up resistor)	(NC)
75	CLDCK	O	Sub-code frame clock signal output when command is defaulted (fCLDCK=7.35kHz) PACK synchronous signal when command is switched	
76	IPFLAG	O	Interpolation flag signal output (H : INTERPOLATION)	(NC)
77	DEMPI /TEST2	I	When IOSEL=H, L : NORMAL H : TEST2 Emphasis control in accordance with DEMPO When IOSEL=L, external DEMP1 input terminal For emphasis control, DEMPO, OR of DEMP1, DEMP1, forced OFF or forced ON is selected by command. When command is defaulted, DEMPO and OR of DEMP1	(GND)
78	SDATI	I	SRDATA input (effective only when IOSEL=L)	(NC)
79	LRCKI	I	LRCK input (effective only when IOSEL=L) H : Lch data, L : Rch data	(NC)
80	BCKI	I	BCK input (effective only when IOSEL=L)	(NC)

■ DISPLAY DATA (V3618100)

V301 : 14-BT-56GN

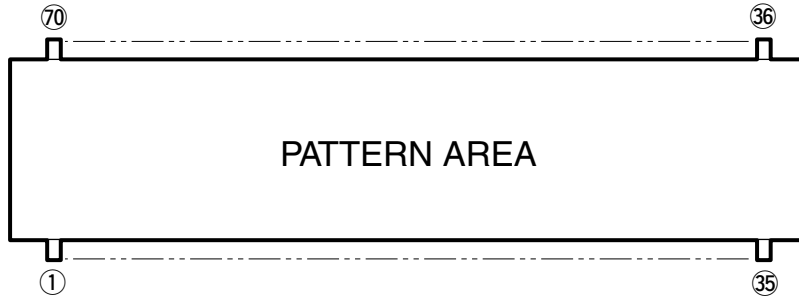

● PIN CONNECTION

Pin No.	1	2	3	4	5	6	7	8	9	10	11	12	13	14	15	16	17	18	19	20	21	22	23	24	25	26	27	28	29	30
Connection	F1	F1	NP	14G	13G	12G	11G	10G	9G	8G	7G	6G	5G	4G	3G	2G	NX	NX	NX	NX	1G	IC	P35	P34	P33	P32	P31	P30	P29	P28
Pin No.	31	32	33	34	35	36	37	38	39	40	41	42	43	44	45	46	47	48	49	50	51	52	53	54	55	56	57	58	59	60
Connection	P27	P26	NP	F2	F2	F2	F2	NP	P25	P24	P23	P22	P21	P20	P19	P18	P17	P16	P15	P14	P13	NX	NX	NX	NX	P12	P11	P10	P9	P8
Pin No.	61	62	63	64	65	66	67	68	69	70																				
Connection	P7	P6	P5	P4	P3	P2	P1	NP	F1	F1																				

- Note** 1) F1, F2 Filament 3) NX No Extend pin 5) 1G~14G Grid
 2) NP No Pin 4) P1~P35 Datum Line 6) IC Internal Connection

● GRID ASSIGNMENT

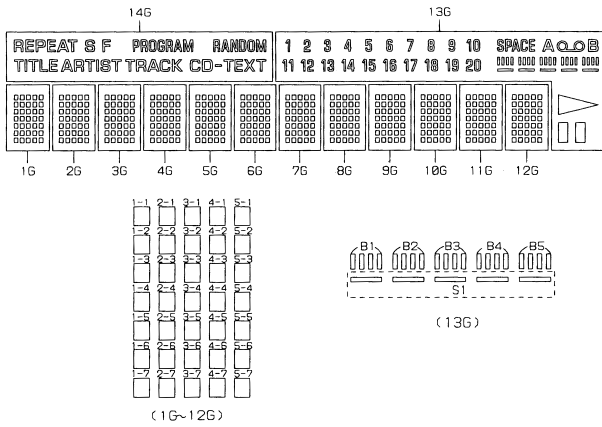

● ANODE CONNECTION

	14G	13G	12G~16G
P1	REPEAT	▶	1-1
P2	S	□□	2-1
P3	F	SPACE	3-1
P4	PROGRAM	A	4-1
P5	RANDOM	○ ○	5-1
P6	TITLE	B	1-2
P7	ARTIST	B1	2-2
P8	TRACK	B2	3-2
P9	CD-TEXT	B3	4-2
P10	-	B4	5-2
P11	-	B5	1-3
P12	-	S1	2-3
P13	-	1	3-3
P14	-	2	4-3
P15	-	3	5-3
P16	-	4	1-4
P17	-	5	2-4
P18	-	6	3-4
P19	-	7	4-4
P20	-	8	5-4
P21	-	9	1-5
P22	-	10	2-5
P23	-	11	3-5
P24	-	12	4-5
P25	-	13	5-5
P26	-	14	1-6
P27	-	15	2-6
P28	-	16	3-6
P29	-	17	4-6
P30	-	18	5-6
P31	-	19	1-7
P32	-	20	2-7
P33	-	-	3-7
P34	-	-	4-7
P35	-	-	5-7

CDX-E400

■ BLOCK DIAGRAM

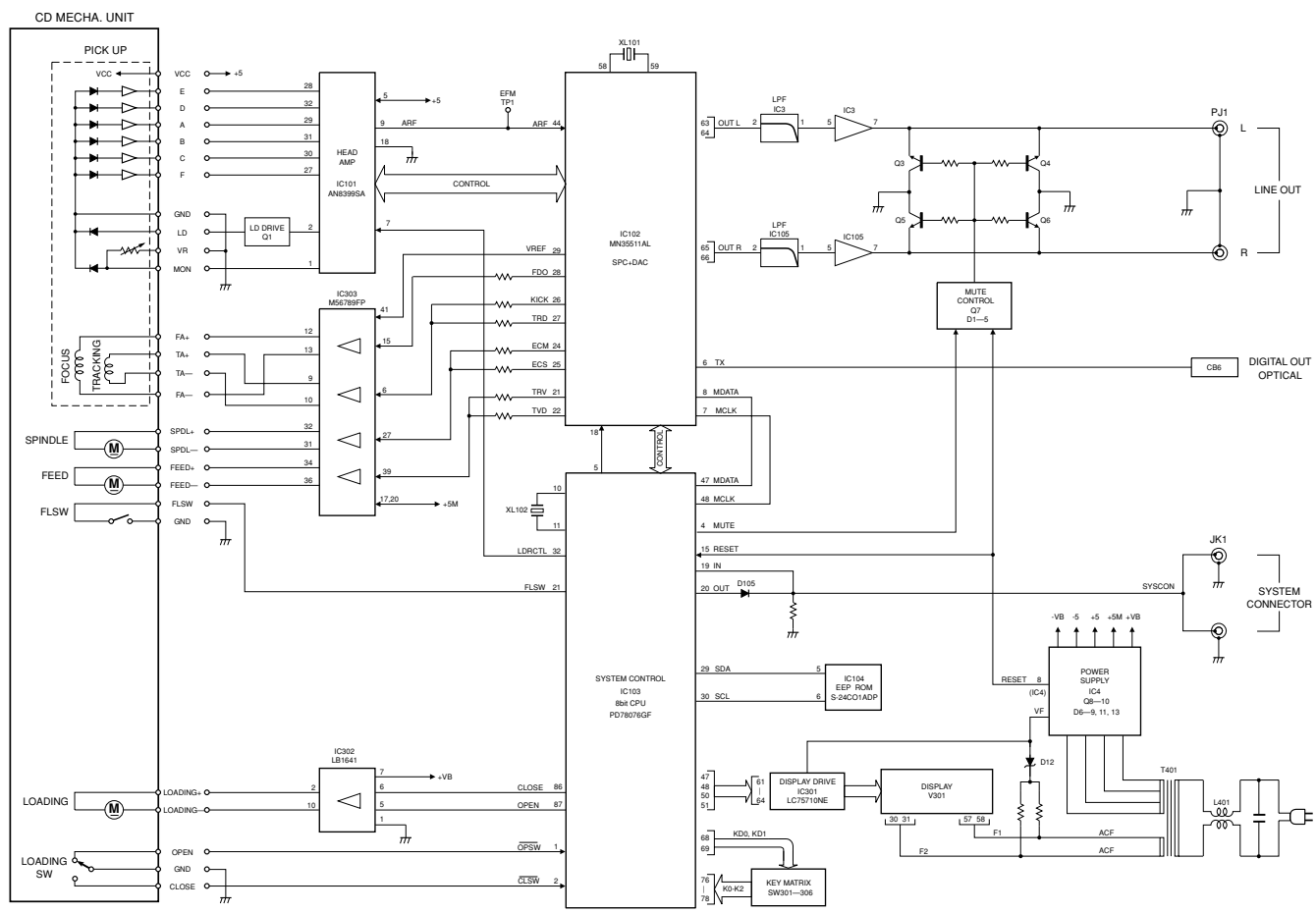

CDX-E400

PRINTED CIRCUIT BOARD (Foil side)

Semiconductor Location

Ref No.	Location
D1	D3
D2	D2
D3	D3
D4	D3
D5	D3
D6	C2
D10	D3
D11	C3
D12	C3
D13	C3
D14	C2
D101	F4
D102	F4
D103	F4
D104	F4
D105	F3
D106	F3

Ref No.	Location
IC3	C4
IC4	C3
IC101	E2
IC102	D3
IC103	F4
IC105	C3
IC302	F3
IC303	F2

Ref No.	Location
Q1	F2
Q2	F2
Q3	B4
Q4	B4
Q5	B3
Q6	B3
Q7	D3
Q8	C3
Q9	D3
Q10	C3
Q102	E3

MAIN (1) P. C. B.

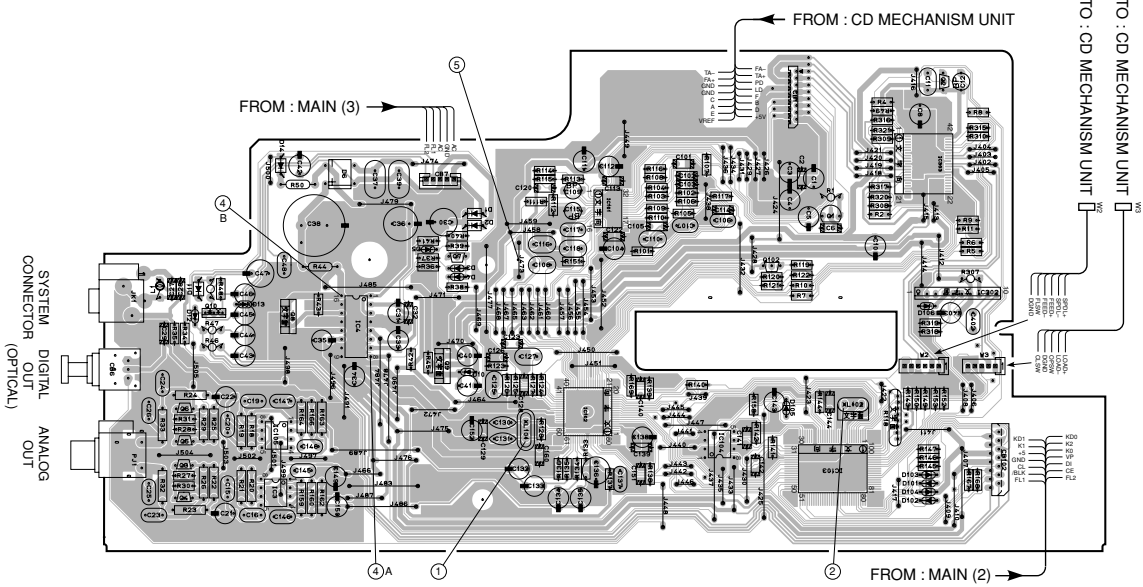

SYSTEM DIGITAL ANALOG
CONNECTOR OUT
(OPTICAL) OUT

Point ① (Pin 59 of IC102)
V : 2V/div, H : 50nsec/div
DC, 1 : 1 probe

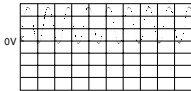

Point ② (Pin 10 of IC103)
V : 2V/div, H : 0.2µsec/div
DC, 1 : 1 probe

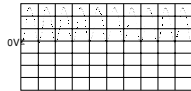

Point ④-A (/RESET : Pin 8 of IC4)
Point ④-B (VCC : Pin 16 of IC4)
V : 2V/div (/RESET), V : 5V/div (VCC)
DC, 1 : 1 probe, H : 5 sec/div

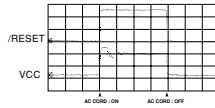

Point ⑤ (EFN)
V : 0.2V/div, H : 0.5µsec/div
AC, 1 : 1 probe

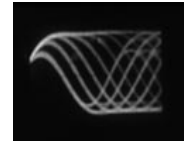

Test disc
SONY YEDS-18 (P/No. TX911730)
A-BEX TCD-782 (P/N. TX913350)
or Philips 5 : x1

■ PRINTED CIRCUIT BOARD (Foil side)

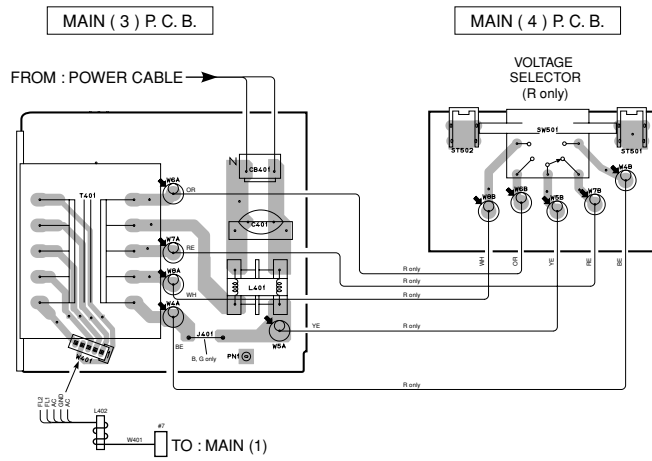
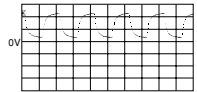
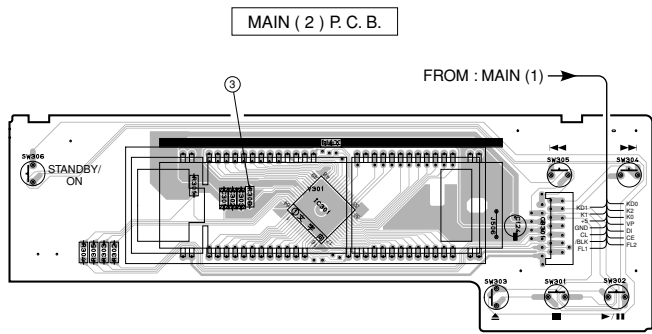

SW501

110V	RE	-	YE
120V	OR	-	YE
220V	WH	-	YE
240V	BE	-	YE

CDX-E400

IC BLOCK

IC303 : M56789FP
4-Channel Actuator Driver

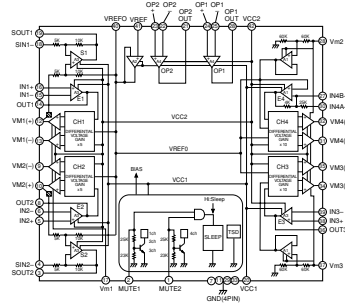

IC101 : AN8399SA
CD Head Amp

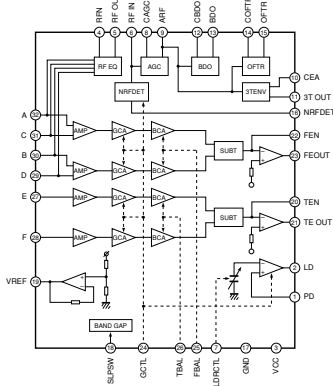

IC301 : LC75710NE
FL Driver

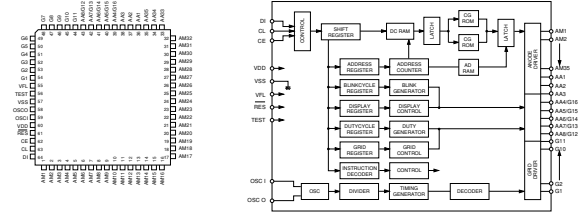

IC302 : LB1641
Motor Driver

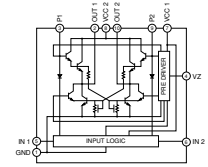

IC3, 105 : NJM2068D-D
Dual OP-Amp

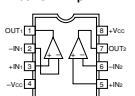

IC104 : S-24C01ADP
Electrically Erasable PROM

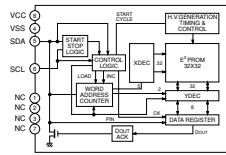

PIN CONNECTION DIAGRAM

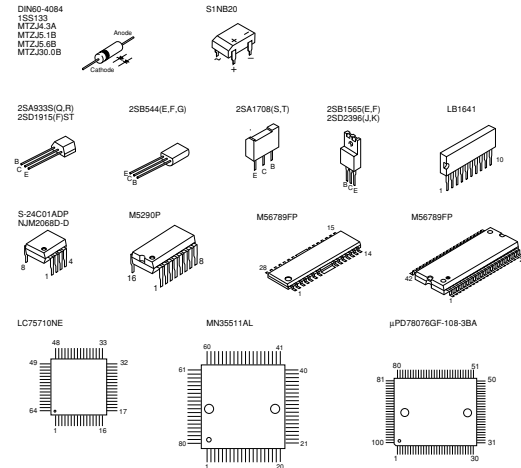

IC4 : M5290P
Constant-Voltage Tracking Supply with Reset

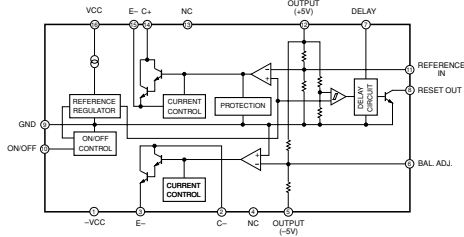

PARTS LIST

■ ELECTRICAL PARTS

■ WARNING

Components having special characteristics are marked \triangle and must be replaced with parts having specifications equal to those originally installed.

- Carbon resistors (1/6W or 1/4W) are not included in the ELECTRICAL PARTS List. For the part Nos. of the carbon resistors, refer to the last page.

ABBREVIATIONS IN THIS LIST ARE AS FOLLOWS :

C.A.EL.CHP	: CHIP ALUMI. ELECTROLYTIC CAP	L.EMIT	: LIGHT EMITTING MODULE
C.CE	: CERAMIC CAP	LED.DSPLY	: LED DISPLAY
C.CE.ARRAY	: CERAMIC CAP ARRAY	LED.INFRD	: LED, INFRARED
C.CE.CHP	: CHIP CERAMIC CAP	MODUL.RF	: MODULATOR, RF
C.CE.ML	: MULTILAYER CERAMIC CAP	PHOT.CPL	: PHOTO COUPLER
C.CE.M.CHP	: CHIP MULTILAYER CERAMIC CAP	PHOT.INTR	: PHOTO INTERRUPTER
C.CE.SAFTY	: RECOGNIZED CERAMIC CAP	PHOT.RFLCT	: PHOTO REFLECTOR
C.CE.TUBLR	: CERAMIC TUBULAR CAP	PIN.TEST	: PIN, TEST POINT
C.CE.SMI	: SEMI CONDUCTIVE CERAMIC CAP	PLST.RIVET	: PLASTIC RIVET
C.EL	: ELECTROLYTIC CAP	R.ARRAY	: RESISTOR ARRAY
C.MICA	: MICA CAP	R.CAR	: CARBON RESISTOR
C.ML.FLM	: MULTILAYER FILM CAP	R.CAR.CHP	: CHIP RESISTOR
C.MP	: METALLIZED PAPER CAP	R.CAR.FP	: FLAME PROOF CARBON RESISTOR
C.MYLAR	: MYLAR FILM CAP	R.FUS	: FUSABLE RESISTOR
C.MYLAR.ML	: MULTILAYER MYLAR FILM CAP	R.MTL.CHP	: CHIP METAL FILM RESISTOR
C.PAPER	: PAPER CAPACITOR	R.MTL.FLM	: METAL FILM RESISTOR
C.PLS	: POLYSTYRENE FILM CAP	R.MTL.OXD	: METAL OXIDE FILM RESISTOR
C.POL	: POLYESTER FILM CAP	R.MTL.PLAT	: METAL PLATE RESISTOR
C.POLY	: POLYETHYLENE FILM CAP	RSNR.CE	: CERAMIC RESONATOR
C.PP	: POLYPROPYLENE FILM CAP	RSNR.CRYS	: CRYSTAL RESONATOR
C.TNTL	: TANTALUM CAP	R.TW.CEM	: TWIN CEMENT FIXED RESISTOR
C.TNTL.CHP	: CHIP TANTALUM CAP	R.WW	: WIRE WOUND RESISTOR
C.TRIM	: TRIMMER CAP	SCR.BND.HD	: BIND HEAD B-TITE SCREW
CN	: CONNECTOR	SCR.BW.HD	: BW HEAD TAPPING SCREW
CN.BS.PIN	: CONNECTOR, BASE PIN	SCR.CUP	: CUP TITE SCREW
CN.CANNON	: CONNECTOR, CANNON	SCR.TERM	: SCREW TERMINAL
CN.DIN	: CONNECTOR, DIN	SCR.TR	: SCREW, TRANSISTOR
CN.FLAT	: CONNECTOR, FLAT CABLE	SUPRT.PCB	: SUPPORT, P.C.B.
CN.POST	: CONNECTOR, BASE POST	SURG.PRTCT	: SURGE PROTECTOR
COIL.MX.AM	: COIL, AM MIX	SW.TACT	: TACT SWITCH
COIL.AT.FM	: COIL, FM ANTENNA	SW.LEAF	: LEAF SWITCH
COIL.DT.FM	: COIL, FM DETECT	SW.LEVER	: LEVER SWITCH
COIL.MX.FM	: COIL, FM MIX	SW.MICRO	: MICRO SWITCH
COIL.OUTPT	: OUTPUT COIL	SW.PUSH	: PUSH SWITCH
DIOD.ARRAY	: DIODE ARRAY	SW.RT.ENC	: ROTARY ENCODER
DIODE.BRG	: DIODE BRIDGE	SW.RT.MTR	: ROTARY SWITCH WITH MOTOR
DIODE.CHP	: CHIP DIODE	SW.RT	: ROTARY SWITCH
DIODE.VAR	: VARACTOR DIODE	SW.SLIDE	: SLIDE SWITCH
DIOD.Z.CHP	: CHIP ZENER DIODE	TERM.SP	: SPEAKER TERMINAL
DIODE.ZENR	: ZENER DIODE	TERM.WRAP	: WRAPPING TERMINAL
DSCR.CE	: CERAMIC DISCRIMINATOR	THRMST.CHP	: CHIP THERMISTOR
FER.BEAD	: FERRITE BEADS	TR.CHP	: CHIP TRANSISTOR
FER.CORE	: FERRITE CORE	TR.DGT	: DIGITAL TRANSISTOR
FET.CHP	: CHIP FET	TR.DGT.CHP	: CHIP DIGITAL TRANSISTOR
FL.DSPLY	: FLUORESCENT DISPLAY	TRANS	: TRANSFORMER
FLTR.CE	: CERAMIC FILTER	TRANS.PULS	: PULSE TRANSFORMER
FLTR.COMB	: COMB FILTER MODULE	TRANS.PWR	: POWER TRANSFORMER ASS'y
FLTR.LC.RF	: LC FILTER ,EMI	TUNER.AM	: TUNER PACK, AM
GND.MTL	: GROUND PLATE	TUNER.FM	: TUNER PACK, FM
GND.TERM	: GROUND TERMINAL	TUNER.PK	: FRONT-END TUNER PACK
HOLDER.FUS	: FUSE HOLDER	VR	: ROTARY POTENTIOMETER
IC.PRTCT	: IC PROTECTOR	VR.MTR	: POTENTIOMETER WITH MOTOR
JUMPER.CN	: JUMPER CONNECTOR	VR.SW	: POTENTIOMETER WITH ROTARY SW
JUMPER.TST	: JUMPER, TEST POINT	VR.SLIDE	: SLIDE POTENTIOMETER
L.DTCT	: LIGHT DETECTING MODULE	VR.TRIM	: TRIMMER POTENTIOMETER

Note) Those parts marked with “#” are not included in the P.C.B. ass'y.

% : Note on the Main PCB

Of the main PCB part Nos., only the gold (GD) type part Nos. are included in the table. (G, B models)
 The only different part between the silver (SI) and gold (GD) type parts is the sheet/FL that is attached to the fluorescent character display tube. When a SI type main PCB becomes necessary, order a GD type main PCB and a SI type sheet/FL (V3688400) and replace the sheet/FL of the GD type main PCB with the SI type sheet/FL.

Schm Ref.	PART NO.	Description	Market
*	V9356200	P.C.B.	GD:MAIN
*	V9356300	P.C.B.	GD:MAIN
CB1	V2731000	CN.FMN	16P
CB6	V4164300	L.EMIT	TOTX178A
CB7	VB390100	CN.BS.PIN	5P
CB102	VN394900	CN.BS.PIN	14P
CB301	VF982200	CN.BS.PIN	14P
CB401	VG879900	CN.BS.PIN	2P
C1	UR818100	C.EL	100uF 6.3V
C2	VJ599100	C.CE.TUBLR	0.1uF 50V
C3	UR818100	C.EL	100uF 6.3V
C4	UR818100	C.EL	100uF 6.3V
C5	UR837470	C.EL	47uF 16V
C6	VF467000	C.CE.TUBLR	1000pF 50V
C8	UR838220	C.EL	220uF 16V
C10	UR838220	C.EL	220uF 16V
C11	VE326000	C.MYLAR.ML	0.1uF 50V
C12	UN865220	C.EL	0.22uF 50V
C15	UA654150	C.MYLAR	0.015uF 50V
C16	UA653330	C.MYLAR	3300pF 50V
C19	UA653330	C.MYLAR	3300pF 50V
C20	UA654150	C.MYLAR	0.015uF 50V
C21	VG287300	C.EL	22uF 50V
C22	VG287300	C.EL	22uF 50V
C23	UA653220	C.MYLAR	2200pF 50V
C24	UA653220	C.MYLAR	2200pF 50V
C25	UA652220	C.MYLAR	220pF 50V
C26	UA652220	C.MYLAR	220pF 50V
C27	VF466800	C.CE.TUBLR	100pF 50V
C28	VF467300	C.CE.TUBLR	0.01uF 16V
C29	VJ599100	C.CE.TUBLR	0.1uF 50V
C30	UR848220	C.EL	220uF 25V
C31	VG286200	C.EL	100uF 10V
C32	VJ599100	C.CE.TUBLR	0.1uF 50V
C33	UR865680	C.EL	0.68uF 50V
C34	VG286200	C.EL	100uF 10V
C35	UR837100	C.EL	10uF 16V
C36	VG287900	C.EL	470uF 16V
△ C37	VK534100	C.PP	0.01uF 100V
C38	Vi578400	C.EL	6800uF 16V
△ C39	VK534100	C.PP	0.01uF 100V
C40	UR837470	C.EL	47uF 16V
C41	UR828100	C.EL	100uF 10V
C42	UR867470	C.EL	47uF 50V
C43	UR866470	C.EL	4.7uF 50V
C44	UR866470	C.EL	4.7uF 50V
C45	UR867470	C.EL	47uF 50V
C46	UR866470	C.EL	4.7uF 50V
C47	UR868100	C.EL	100uF 50V
C48	Vi716700	C.MYLAR	0.01uF 50V
C101	VJ599100	C.CE.TUBLR	0.1uF 50V
C102	VJ599100	C.CE.TUBLR	0.1uF 50V
C103	VJ599100	C.CE.TUBLR	0.1uF 50V

* New Parts

Schm Ref.	PART NO.	Description	Market
C104	V4749000	C.EL	150uF 6.3V
C105	VG277700	C.CE.TUBLR	68pF 50V
C106	UA653100	C.MYLAR	1000pF 50V
C107	UA653150	C.MYLAR	1500pF 50V
C108	UA654470	C.MYLAR	0.047uF 50V
C109	UN865470	C.EL	0.47uF 50V
C110	VE326000	C.MYLAR.ML	0.1uF 50V
C111	V4749000	C.EL	150uF 6.3V
C112	UR818100	C.EL	100uF 6.3V
C113	VJ599100	C.CE.TUBLR	0.1uF 50V
C114	VJ599000	C.CE.TUBLR	0.047uF 16V
C115	UN865100	C.EL	0.10uF 50V
C116	UA654470	C.MYLAR	0.047uF 50V
* C117	UA653680	C.MYLAR	6800pF 50V
C118	UA654470	C.MYLAR	0.047uF 50V
C120	VG276600	C.CE.TUBLR	22pF 50V
C122	VJ599100	C.CE.TUBLR	0.1uF 50V
C123	VF466900	C.CE.TUBLR	470pF 50V
C124	UM397470	C.EL	47uF 16V
C125	UA654680	C.MYLAR	0.068uF 50V
C126	VJ599100	C.CE.TUBLR	0.1uF 50V
C127	VE326000	C.MYLAR.ML	0.1uF 50V
C128	VJ599100	C.CE.TUBLR	0.1uF 50V
C129	VJ599100	C.CE.TUBLR	0.1uF 50V
C130	VA761400	C.CE	47pF 50V
C131	VA761400	C.CE	47pF 50V
C132	VG290600	C.EL	2.2uF 50V
C133	VG290600	C.EL	2.2uF 50V
C134	VG290600	C.EL	2.2uF 50V
C135	VG290600	C.EL	2.2uF 50V
C136	VG286500	C.EL	470uF 10V
C137	Vi716700	C.MYLAR	0.01uF 50V
C138	UR818100	C.EL	100uF 6.3V
C139	VJ599100	C.CE.TUBLR	0.1uF 50V
C140	VJ599100	C.CE.TUBLR	0.1uF 50V
C141	VJ599100	C.CE.TUBLR	0.1uF 50V
C142	VJ599100	C.CE.TUBLR	0.1uF 50V
C143	UR818100	C.EL	100uF 6.3V
C144	VF467300	C.CE.TUBLR	0.01uF 16V
C145	UA652100	C.MYLAR	100pF 50V
C146	UA652470	C.MYLAR	470pF 50V
C147	UA652470	C.MYLAR	470pF 50V
C148	UA652100	C.MYLAR	100pF 50V
C149	VG286200	C.EL	100uF 10V
C150	VG286200	C.EL	100uF 10V
C151	VJ599100	C.CE.TUBLR	0.1uF 50V
C152	UR818100	C.EL	100uF 6.3V
C160	VJ599100	C.CE.TUBLR	0.1uF 50V
C301	VJ599100	C.CE.TUBLR	0.1uF 50V
C302	VJ599100	C.CE.TUBLR	0.1uF 50V
C303	VG276600	C.CE.TUBLR	22pF 50V
* C401	VR814900	C.CE.SAFETY	0.047uF 250V
C402	UA654100	C.MYLAR	0.01uF 50V

* New Parts

CDX-E400

Schm Ref.	PART NO.	Description	Market
C403	UR828100	C.EL 100uF 10V	
△ *	D1 V8911600	DIODE DIN60-4084	
△ *	D2 V8911600	DIODE DIN60-4084	
	D3 VD631600	DIODE 1SS133, 176	
	D4 VD631600	DIODE 1SS133, 176	
	D5 VG437400	DIODE.ZENR MTZJ5.1B 5.1V	
△	D6 VR253700	DIODE.BRG S1NB20 1A 200V	
	D10 VG437700	DIODE.ZENR MTZJ5.6B 5.6V	
△ *	D11 V8911600	DIODE DIN60-4084	
	D12 VG437700	DIODE.ZENR MTZJ5.6B 5.6V	
	D13 VG443300	DIODE.ZENR MTZJ30B 30V	
△ *	D14 V8911600	DIODE DIN60-4084	
	D101 VD631600	DIODE 1SS133, 176	
	D102 VD631600	DIODE 1SS133, 176	
	D103 VD631600	DIODE 1SS133, 176	
	D104 VD631600	DIODE 1SS133, 176	
	D105 VD631600	DIODE 1SS133, 176	
	D106 VG436700	DIODE.ZENR MTZJ4.3A 4.3V	
	IC3 XA987A00	IC NJM2068D-D	
	IC4 XD201A00	IC M5290P	
	IC101 XZ652A00	IC AN8399SA	
	IC102 XW915A00	IC MN35511AL	
*	IC103 X3245A00	IC.CPU UPD78076GF-108-3BA	
	IC104 XS070A00	IC S-24C01ADP EEPROM	
	IC105 XA987A00	IC NJM2068D-D	
	IC301 XR188A00	IC LC75710NE FLD	
	IC302 XF494A00	IC LB1641	
*	IC303 XV102A00	IC M56789FP	
	JK1 V3576300	JACK 2P	
	L1 GE300610	FER.BEAD BL02RN1-R62T4	
△	L401 VU984000	FLTR IE-UU10.5-009	
	L402 V6660800	FER.CORE F5 T19x10x10	
*	PJ1 V7720900	JACK.PIN LPR6520-E510M	
	PN1 V3750100	PIN L=50	
	Q1 iB054430	TR 2SB544 D,E,F,G	
	Q2 VK432900	TR 2SD1915F S,T	
	Q3 VK432900	TR 2SD1915F S,T	
	Q4 VK432900	TR 2SD1915F S,T	
	Q5 VK432900	TR 2SD1915F S,T	
	Q6 VK432900	TR 2SD1915F S,T	
	Q7 iA093320	TR 2SA933S Q,R	
	Q8 VS883300	TR 2SB1565 E,F	
	Q9 VR510800	TR 2SD2396 J,K	
	Q10 VP872600	TR 2SA1708 S,T	
	Q102 VK432900	TR 2SD1915F S,T	
	R1 HV754100	R.CAR.FP 10 1/4W	
△	R44 V2370600	R.FUS 0.47 1/6W	
	R46 HV755100	R.CAR.FP 100 1/4W	
	R47 HV755100	R.CAR.FP 100 1/4W	
	R50 V2370600	R.FUS 0.47 1/6W	
	R51 HV754100	R.CAR.FP 10 1/4W	
	R118 VL207800	R.ARRAY RGL7X473J	
	R307 HV754100	R.CAR.FP 10 1/4W	

* New Parts

Schm Ref.	PART NO.	Description	Market
ST501	V4040500	SCR.TERM M3	R
ST502	V4040500	SCR.TERM M3	R
SW301	VV020300	SW.TACT SKQNAA	
SW302	VV020300	SW.TACT SKQNAA	
SW303	VV020300	SW.TACT SKQNAA	
SW304	VV020300	SW.TACT SKQNAA	
SW305	VV020300	SW.TACT SKQNAA	
SW306	VV020300	SW.TACT SKQNAA	
△	SW501 VG388100	VOLT.SELCT HXW0244-01-080	R
△	T401 XN394A00	TRANS.PWR	R
△	T401 XN393A00	TRANS.PWR	BG
	V301 V3618100	FL.DSPLY 14-BT-56GN	
	XL101 VJ719800	RSNR.CRYS 16.9344MHz	
	XL102 VU763600	RSNR.CE 5MHz	
		VQ948800 SHEET.FL GD	
%		V3688400 SHEET.FL SI	
		V3747500 SUPRT	
		V3747400 SPACER.FL T4x6x18	

* New Parts

MECHANICAL PARTS

Ref. No.	PART NO.	Description	Remarks	Markets
1-11	MF114100	FLEXIBLE FLAT CABLE	14P 100mm	
* 1-101	V8782200	FRONT PANEL		SI
* 1-101	V8782300	FRONT PANEL		GD
* 1-102	V8782400	SUB PANEL-CDX		SI
* 1-102	V8782500	SUB PANEL-CDX		GD
* 1-103	V8785200	PANEL/SIDE	H100	
* 1-104	V8782600	SHEET		
1-110	VQ368600	PUSH RIVET	P3555-B	
1-111	VF617600	PAN HEAD P-TITE SCREW	2.6x8 MFC2BL	
* 2	V9356200	P.C.B. ASS'Y	GD:MAIN	R
* 2	V9356300	P.C.B. ASS'Y	GD:MAIN	GB
5	VZ573200	CD MECHANISM UNIT	KSL-2130CCM	
△ 11	VZ542500	POWER CABLE	2m	R
△ * 11	V9293600	POWER CABLE	2m	G
△ 11	VV437300	POWER CABLE	2m	B
12	V2438700	CORD STOPPER	10P1	
* 15	V8835000	SUMI-CARD C&C	16P 100mm P=1.00	
101	V7127300	TOP COVER		SI
101	V7127400	TOP COVER		GD
* 103	V8783000	REAR PANEL		R
* 103	V8783200	REAR PANEL		G
* 103	V8783100	REAR PANEL		B
* 106	V8782700	LID, CD		SI
* 106	V8782800	LID, CD		GD
110	V3688500	LEG	M0080-M0	
120	VR264400	SPACER	H8	
121	VQ390100	DAMPER	8x8x15	
122	VP857700	DAMPER	4x6x5	
140	VN413300	BIND HEAD BONDING B-T. SCREW	3x8 MFZN2BL	
142	EP600830	BIND HEAD B-TITE SCREW	3x8 MFC2BL	
143	EP600250	BIND HEAD B-TITE SCREW	3x8 MFZN2Y	
144	VT669300	PW HEAD B-TITE SCREW	3x8-8 MFC2	
145	VT669400	PW HEAD B-TITE SCREW	3x15-8 MFC2	
146	V2728500	BIND HEAD S-TITE SCREW	4x7 MFZN2BL	
148	EL300650	PW HEAD B-TITE SCREW	3x8-8 MFC2BL	
149	EP600790	FLAT HEAD B-TITE SCREW	3x8 MFZN2BL	
150	VY712800	PW HEAD B-TITE SCREW	3x8-8 MFN133	
151	EP630210	BIND HEAD S-TITE SCREW	3x6 MFZN2BL	
152	EG330030	BIND HEAD SCREW	3x6 MFC2BL	
%	V3688400	SHEET, FL	SI	SI

* New Parts

% : Note on the Main PCB

Of the main PCB part Nos., only the gold (GD) type part Nos. are included in the table. (G, B models)

The only different part between the silver (SI) and gold (GD) type parts is the sheet/FL that is attached to the fluorescent character display tube. When a SI type main PCB becomes necessary, order a GD type main PCB and a SI type sheet/FL (V3688400) and replace the sheet/FL of the GD type main PCB with the SI type sheet/FL.

CDX-E400

EXPLODED VIEW (CD Mechanism Unit)

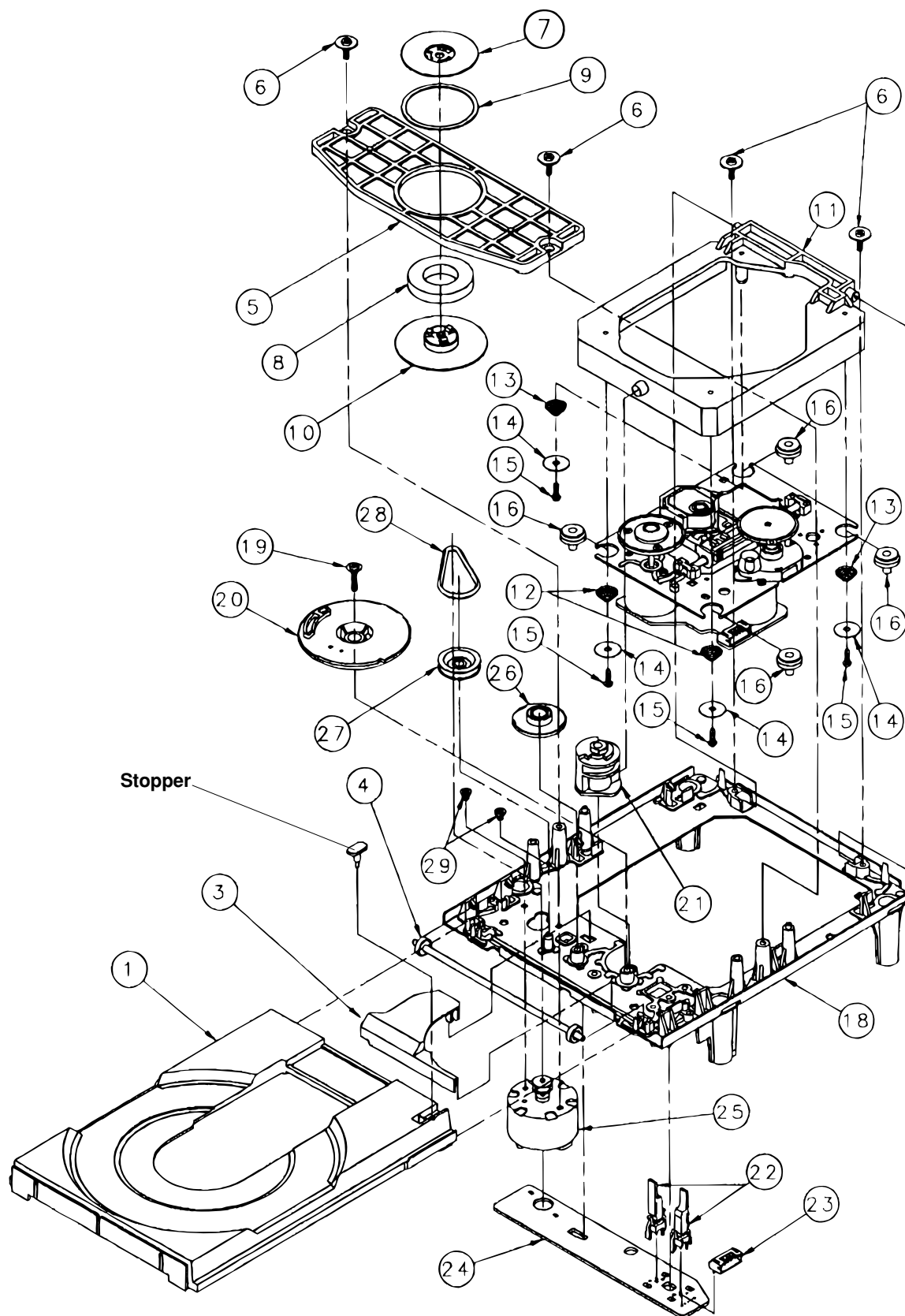

* The stopper is not supplied with the tray as a spare part.

When replacing the tray, keep the removed stopper and reuse it.

Should it be lost and a new one be necessary, order service part ⑱ Main Chassis (S) and remove the stopper only from it and use it as a spare part.

■ MECHANICAL PARTS (CD Mechanism Unit)

Ref. No.	PART NO.	Description	Remarks	Markets
	VZ573200	CD MECHANISM UNIT	KSL-2130CCM	
1	CX680620	TRAY (C)	2130	264629001
3	CX675250	GEAR COVER (S)		262554401
4	CX675210	TRAY GEAR (S)		262553501
5	AX619150	CHUCKING PLATE (S)		262554601
6	EX602890	BW HEAD P-TITE SCREW	2.6x7	262629401
7	BX602660	CHUCKING YOKE (S)		262553701
8	NX610570	MAGNET ASS'Y		145249321
9	CX675240	DAMPER (S)		262554102
10	NX636010	CHUCKING PULLEY		264629101
11	AX624650	SUB CHASSIS ASS'Y (S)		264628801
12	AX624640	COIL, SPRING (F)		264723601
13	AX624630	COIL, SPRING (R)		262723501
14	AX624660	WASHER	2130	264628901
15	EX604270	P-TITE SCREW	2.6x10	768513511
16	AX624620	INSULATOR		262723401
18	AX619160	MAIN CHASSIS (S), OUTSERT		262555206
19	VH554700	BW HEAD P-TITE SCREW	2.6x16	331950151
20	CX675270	DRIVE GEAR (S)		262554701
21	CX675260	CONTROL CAM (S)		262554504
22	KX604780	LEAF SWITCH		169266711
23	LX608390	CONNECTOR PIN	5P	156472111
24	NX613050	PWB, LOADIND (S)		164052311
25	JX601470	LOADING MOTOR ASS'Y		X26251171
26	CX675200	CENTER GEAR (S)		262527402
27	CX675220	LOADING PULLEY (S)		262553602
28	CX610840	BELT, LOADING MOTOR		365338700
29	EX602880	SCREW	2.6x2.5	262527901

* New Parts

CDX-E400

EXPLODED VIEW (Drive Unit)

Note : The parts marked with an asterisk (*) are not available separately.

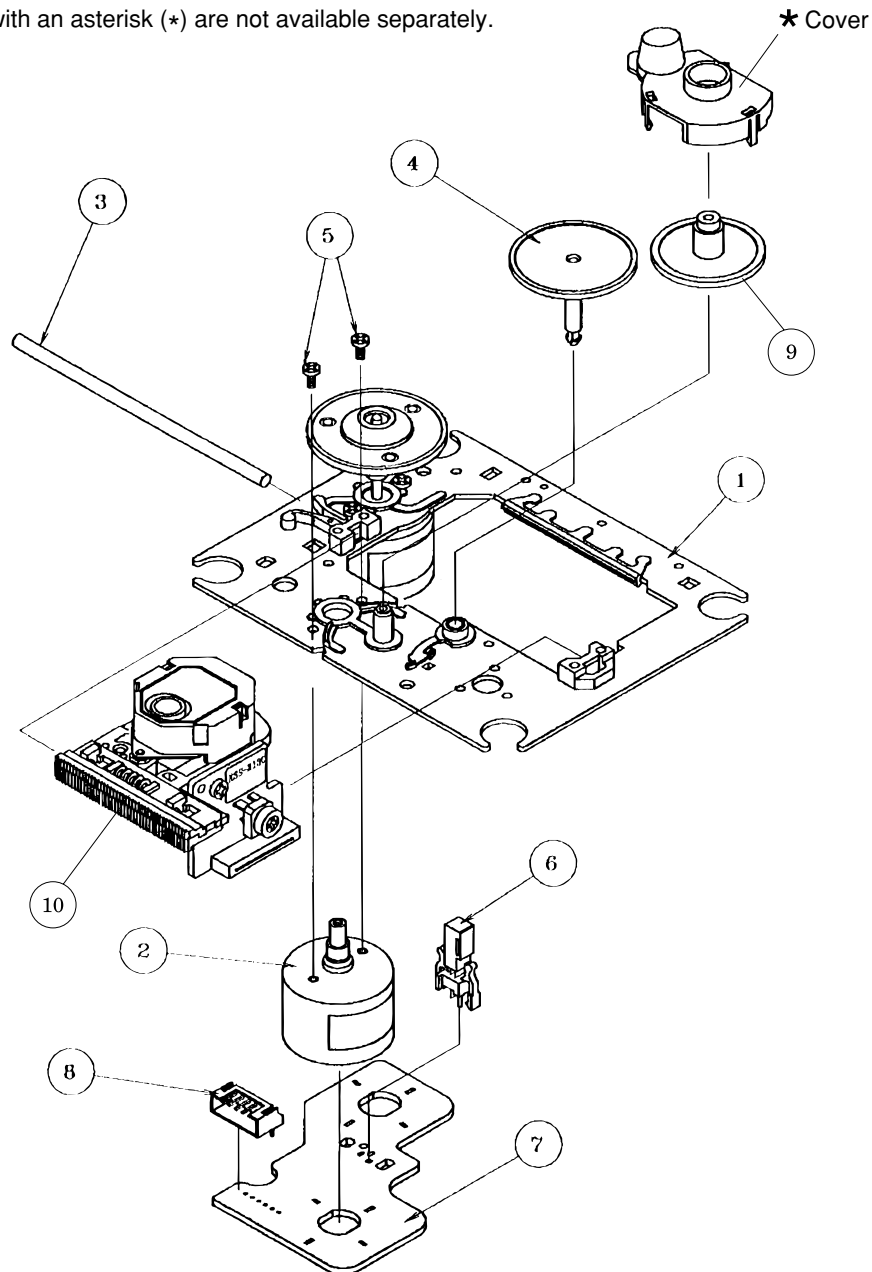

Ref. No.	PART NO.	Description	Remarks	Markets
1	NX635420	MOTOR CHASSIS ASS'Y	(MB)	X26258771
2	CX679710	MOTOR GEAR ASS'Y		X26257691
3	AX623980	SLED SHAFT		262690801
4	CX679720	GEAR, A	(S)	262690701
5	EA020036	PAN HEAD SCREW	2x3 ZMC2-Y	762125515
6	KX604660	LEAF SWITCH		157208511
7	NX613040	PWB, MOTOR	MOTOR 6P	163967812
8	LX610120	CONNECTOR PIN	6P	156472211
9	CX680030	GEAR		262700301
10	NX636020	OPTICAL HEAD		KSM213C

* New Parts

Parts List for Carbon Resistors

Value	1/4W Type Part No.	1/6W Type Part No.	Value	1/4W Type Part No.	1/6W Type Part No.
1.0 Ω	HJ35 3100	HF85 3100	10 kΩ	HF45 7100	HF45 7100
1.8 Ω	HJ35 3180	*	11 kΩ	HF45 7110	HF45 7110
2.2 Ω	HJ35 3220	HF85 3220	12 kΩ	HJ35 7120	HF85 7120
3.3 Ω	HJ35 3330	HF85 3330	13 kΩ	HF45 7130	HF45 7130
4.7 Ω	HJ35 3470	HF85 3470	15 kΩ	HF45 7150	HF45 7150
5.6 Ω	HJ35 3560	HF85 3560	18 kΩ	HF45 7180	HF45 7180
10 Ω	HF45 4100	HF45 4100	22 kΩ	HF45 7220	HF45 7220
15 Ω	HJ35 4150	HF85 4150	24 kΩ	HF45 7240	HF45 7240
22 Ω	HF45 4220	HF45 4220	27 kΩ	HJ35 7270	HF85 7270
27 Ω	HJ35 4270	HF85 4270	30 kΩ	HF45 7300	HF45 7300
33 Ω	HF45 4330	HF45 4330	33 kΩ	HF45 7330	HF45 7330
39 Ω	HJ35 4470	HF85 4390	36 kΩ	HF45 7360	HF45 7360
47 Ω	HF45 4470	HF45 4470	39 kΩ	HF45 7390	HF45 7390
56 Ω	HF45 4560	HF45 4560	47 kΩ	HF45 7470	HF45 7470
68 Ω	HF45 4680	HF45 4680	51 kΩ	HF45 7510	HF45 7510
75 Ω	HF45 4750	HF45 4750	56 kΩ	HF45 7560	HF45 7560
82 Ω	HF45 4820	HF45 4820	62 kΩ	HF45 7620	HF45 7620
91 Ω	HF45 4910	HF45 4910	68 kΩ	HF45 7680	HF45 7680
100 Ω	HF45 5100	HF45 5100	82 kΩ	HF45 7820	HF45 7820
110 Ω	HJ35 5110	HF85 5110	91 kΩ	HF45 7910	HF45 7910
120 Ω	HF45 5120	HF45 5120	100 kΩ	HF45 8100	HF45 8100
150 Ω	HF45 5150	HF45 5150	110 kΩ	HF45 8110	HF45 8110
160 Ω	HJ35 5160	*	120 kΩ	HF45 8120	HF45 8120
180 Ω	HF45 5180	HF45 5180	150 kΩ	HF45 8150	HF45 8150
200 Ω	HF45 5200	HF45 5200	180 kΩ	HF45 8180	HF45 8180
220 Ω	HF45 5220	HF45 5220	220 kΩ	HJ35 8220	HF85 8220
270 Ω	HF45 5270	HF45 5270	270 kΩ	HF45 8270	HF45 8270
330 Ω	HF45 5330	HF45 5330	300 kΩ	HF45 8300	HF45 8300
390 Ω	HF45 5390	HF45 5390	330 kΩ	HF45 8330	HF45 8330
430 Ω	HF45 5430	HF45 5430	390 kΩ	HJ35 8390	HF85 8390
470 Ω	HF45 5470	HF45 5470	470 kΩ	HF45 8470	HF45 8470
510 Ω	HF45 5510	HF45 5510	560 kΩ	HJ35 8560	HF85 8560
560 Ω	HF45 5560	HF45 5560	680 kΩ	HJ35 8680	HF85 8680
680 Ω	HF45 5680	HF45 5680	820 kΩ	HJ35 8820	HF85 8820
820 Ω	HF45 5820	HF45 5820	1.0 MΩ	HF45 9100	HF45 9100
910 Ω	HF45 5910	HF45 5910	1.2 MΩ	HJ35 9120	*
1.0 kΩ	HF45 6100	HF45 6100	1.5 MΩ	HJ35 9150	HF85 9150
1.2 kΩ	HF45 6120	HF45 6120	1.8 MΩ	HJ35 9180	HF85 9180
1.5 kΩ	HF45 6150	HF45 6150	2.2 MΩ	HJ35 9220	HF85 9220
1.8 kΩ	HF45 6180	HF45 6180	3.3 MΩ	HJ35 9330	HF85 9330
2.0 kΩ	HJ35 6200	HF85 6200	3.9 MΩ	HJ35 9390	*
2.2 kΩ	HF45 6220	HF45 6220	4.7 MΩ	HJ35 9470	HF85 9470
2.4 kΩ	HJ35 6240	HF85 6240			
2.7 kΩ	HF45 6270	HF45 6270			
3.0 kΩ	HF45 6300	HF45 6300			
3.3 kΩ	HF45 6330	HF45 6330			
3.6 kΩ	HJ35 6360	HF85 6360			
3.9 kΩ	HF45 6390	HF45 6390			
4.7 kΩ	HF45 6470	HF45 6470			
5.1 kΩ	HF45 6510	HF45 6510			
5.6 kΩ	HF45 6560	HF45 6560			
6.8 kΩ	HF45 6680	HF45 6680			
8.2 kΩ	HF45 6820	HF45 6820			
9.1 kΩ	HF45 6910	HF45 6910			

1/4W Type

HJ35 ○○○○

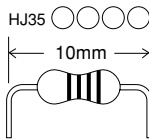

10mm

1/6W Type

HF85 ○○○○

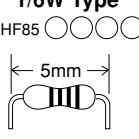

5mm

CDX-E400

YAMAHA

CDX-E400