

C 521BEE

**COMPACT
DISC PLAYER**

C 521BEE

**COMPACT
DISC PLAYER**

SERVICE MANUAL



SAFETY INFORMATION

CAUTION

CAUTION - INVISIBLE LASER RADIATION WHEN OPEN AND INTERLOCKS DEFEATED. AVOID EXPOSURE TO BEAM.

ADVARSEL - USYNLIG LASERSTRÅLING NÅR DEKSEL ÅPNES OG SIKKERHEDSLÅS BRYTES. UNNGÅ EKSPONERING FOR STRÅLEN.

ADVARSEL - USYNLIG LASERSTRÅLING VED ÅBNING, NÅR SIKKERHEDSAFBRYDERE ER UDE AF FUNKTION. UNDGÅ UDSÆTTELSE FOR STRÅLING.

VARNING - OSYNLIG LASERSTRÅLNING NÅR DENNA DEL ÄR ÖPPNAD OCH SPÄRRAR ÄR URKOPPLADE. STRÅLEN ÄR FARLIG.

VARO! - AVATTAESSA JA SUOJALUKITUS OHITETTAESSA OLET ALTIINA NÄKTMÄTÖNTÄ LASERSÄTEILYLLE. ÄLÄ KAISO SÄTEESEEN.

VORSICHT! - UNSICHTBARE LASERSTRAHLUNG TRITTS AUS, WENN DECKEL GEÖFFNET UND WENN SICHERHEITSPERRUNG ÜBERBRÜCKT IST. NICHT DEM STRAHL AUSSETZEN.

**CLASS 1
LASER PRODUCT**

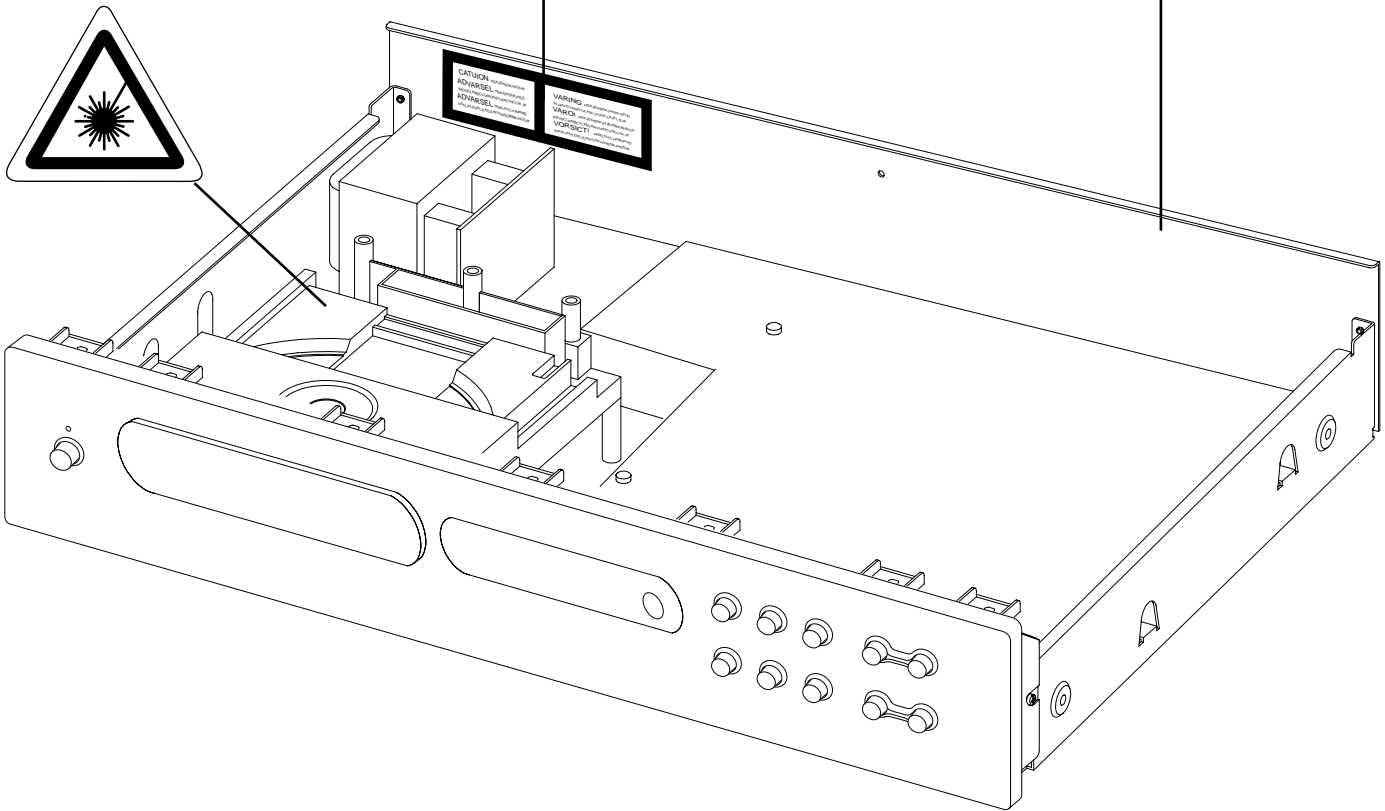

The lightning flash with arrowhead, within an equilateral triangle is intended to alert the user of the presence of uninsulated "dangerous voltage" within the product's enclosure; that may be of sufficient magnitude to constitute a risk of electric shock to persons.



The exclamation point within an equilateral triangle is intended to alert the user of the presence of important operating and maintenance (servicing) instructions in the literature accompanying the appliance.

THIS DEVICE COMPLIES WITH PART 15 OF THE FCC RULES. OPERATION IS SUBJECT TO THE FOLLOWING TWO CONDITIONS:-
(1) THIS DEVICE MAY NOT CAUSE HARMFUL INTERFERENCE, AND
(2) THIS DEVICE MUST ACCEPT ANY INTERFERENCE RECEIVED, INCLUDING INTERFERENCE THAT MAY CAUSE UNDESIRED OPERATION.

SERVICE SAFETY PRECAUTIONS

1. Replacing the fuses

CAUTION: FOR CONTINUED PROTECTION AGAINST THE RISK OF FIRE REPLACE ONLY WITH SAME TYPE OF FUSE.

Reference No		Part Number	Description
M502-M504	*AH \triangle	5120-0020-0	FU T1A 250V UL/CSA 5x20MM
M502-M504	*C \triangle	5120-0018-0	FU T1A 250V SEMKO/UDE 5x20MM
M505	*AH \triangle	5120-0052-0	FUSE T1.6A 250V 5x20MM UL/CSA
M505	*C \triangle	5120-0050-0	FUSE T1.6A 250V 5x20MM SEMKO/VDE

NOTE:

<*AH > : USA, CANADIAN MODEL ONLY.

<*C > : EUROPEAN MODEL ONLY.

2. Safety check out

(Only U.S.A. model)

Before returning the product to the customer, make leakage current or resistance measurements to determine that exposed parts are acceptably insulated from the supply circuit.

Parts marked with the symbol \triangle are critical with regard to the risk of fire and electric shock. Replace only with parts recommended by the manufacturer.

CONTENTS

DESCRIPTION	PAGE
SPECIFICATIONS	4
REAR PANEL / FRONT PANEL	5
DISASSEMBLY INSTRUCTIONS	6
BLOCK DIAGRAM	7
WIRING DIAGRAM	8
RF PATTERN TESTING	9
IMPORTANT NOTES	10-11
PCB LAYOUT	12-13
SCHEMATIC DIAGRAM	14-17
IC BLOCK DIAGRAM	18-21
TROUBLESHOOTING GUIDE	22
ELECTRICAL PARTS LIST	23-27
MECHANISM EXPLODED VIEW	28
MECHANISM EXPLODED VIEW PARTS LIST	29
EXPLODED VIEW	30
EXPLODED VIEW PARTS LIST	31-33
PACKING DIAGRAM	33

SPECIFICATIONS

Disc Capacity	One Disc, 120 or 80 mm
Decoding	BURR-BROWN Delta Sigma 20bit
Digital Filter	8 Times oversample
Analog Filter	4 pole active
Frequency Response	+/- 0.5 dB, 5Hz - 20kHz
De-Emphasis Error	+/- 0.3 dB
THD (at 0 dB, 1kHz)	0.003%
Intermodulation Distortion (19 + 20 kHz)	< - 100 dB
Dynamic Range	96 dB
Linearity	+/- 0.5 dB, 0 dB to -80 dB
Signal / Noise Ratio (A-Weight)	≥106 dB, De-Emphasis on ≥106 dB, De-Emphasis off
Channel Separation 1kHz	>90 dB
10 kHz	>80 dB
Wow and Flutter	Unmeasurable (Quartz Crystal Accuracy)
Output Impedance	200 Ω
Output Level at 0 dB	2.1 V rms
Digital Error Correction	IRC with double error correction in C1 and C2
Digital Code Output	Sony / Philips Serial data format
Power Consumption	12W

CONTROLS

Play / Pause, Stop, Random, Skip (< >), Scan (< >), Open, Time, Repeat.

PHYSICAL SPECIFICATIONS

Dimensions (Width x Height x Depth)	435 x 80 x 285 mm
Net weight	4 kg (8.8 lbs)
Shipping weight	5.1 kg (11.22 lbs)

REAR PANEL / FRONT PANEL

REAR PANEL

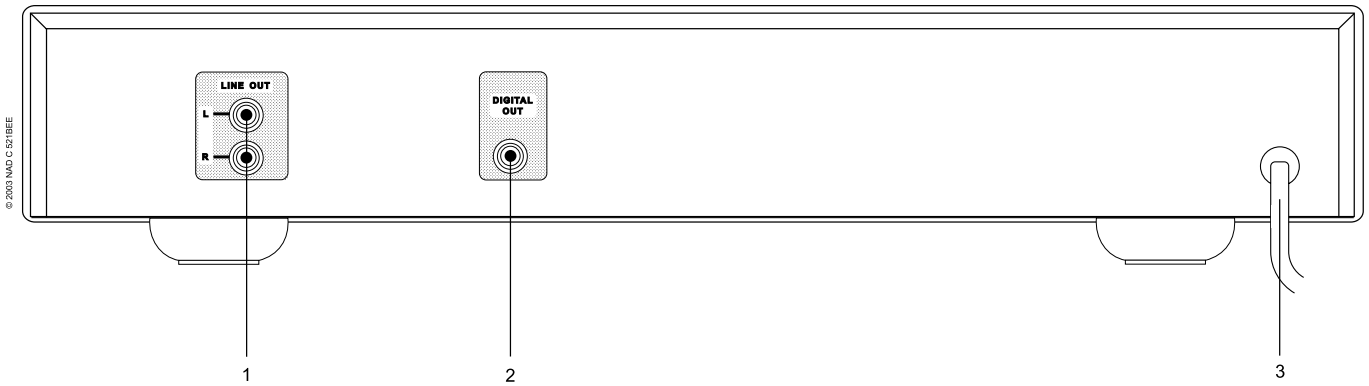

1. LINE OUT
2. DIGITAL OUT

3. AC LINE CORD

FRONT PANEL

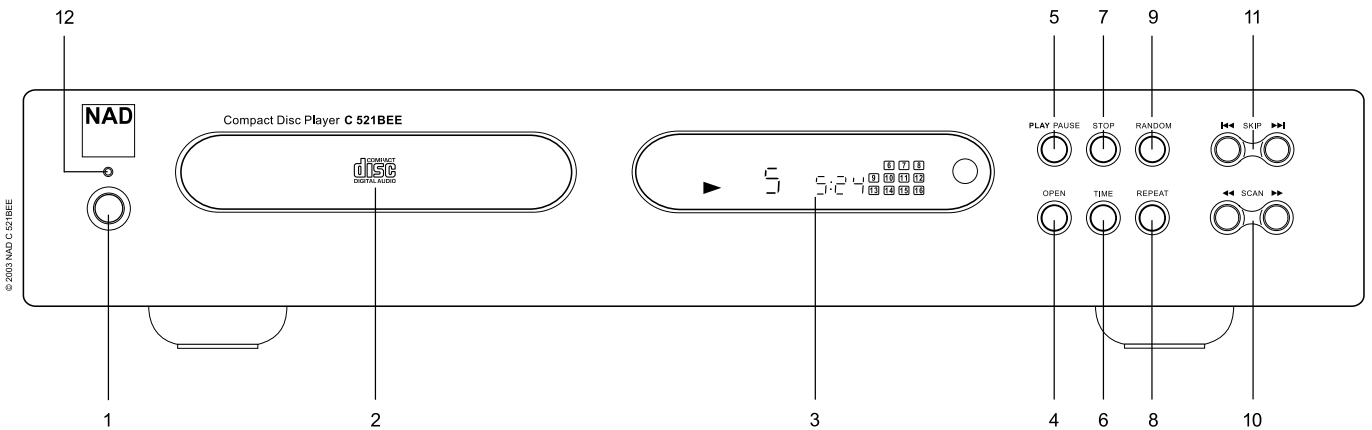

1. POWER ON / OFF
2. DISC DRAWER
3. DISPLAY
4. OPEN
5. PLAY / PAUSE
6. TIME

7. STOP
8. REPEAT
9. RANDOM
10. SCAN Back (◀◀) / Forward (▶▶)
11. SKIP Back (◀◀◀) / Forward (▶▶▶)
12. STANDBY LED

DISASSEMBLY INSTRUCTIONS

1. Remove machine screws M 4.0 x 6.0 (① to ④) from the side panels.
Remove tapping screw 3.0 x 8.5 (⑤) from the back panel.
Refer to **Figure No.1**.

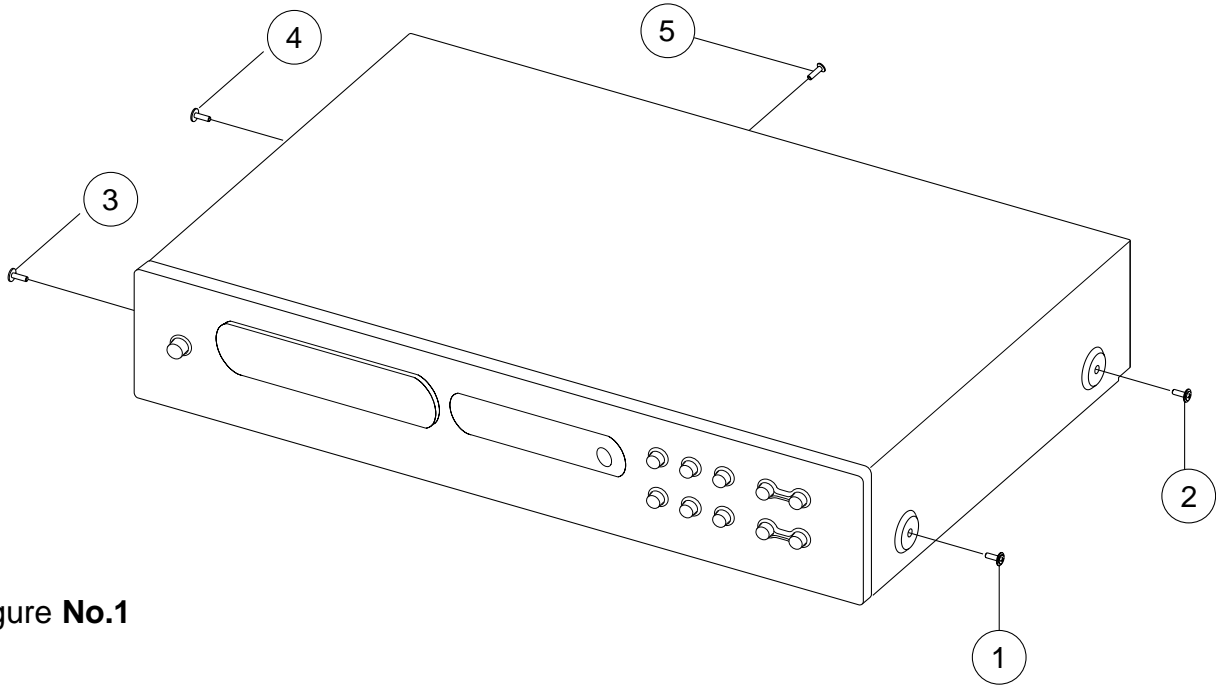

Figure No.1

2. Pull both sides of the TOP COVER slightly outwards (⑥) and tilt approx. 35° and then remove in the direction as indicated by the arrow (⑦). Refer to **Figure No.2**.

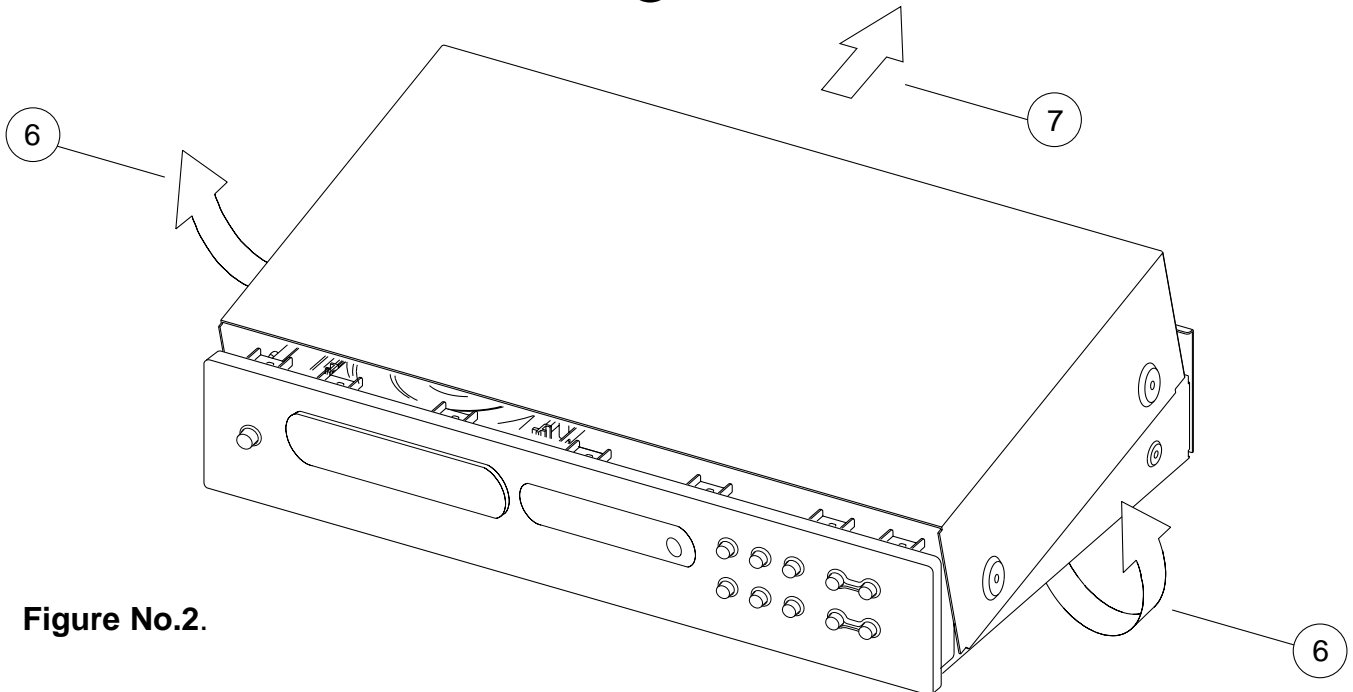
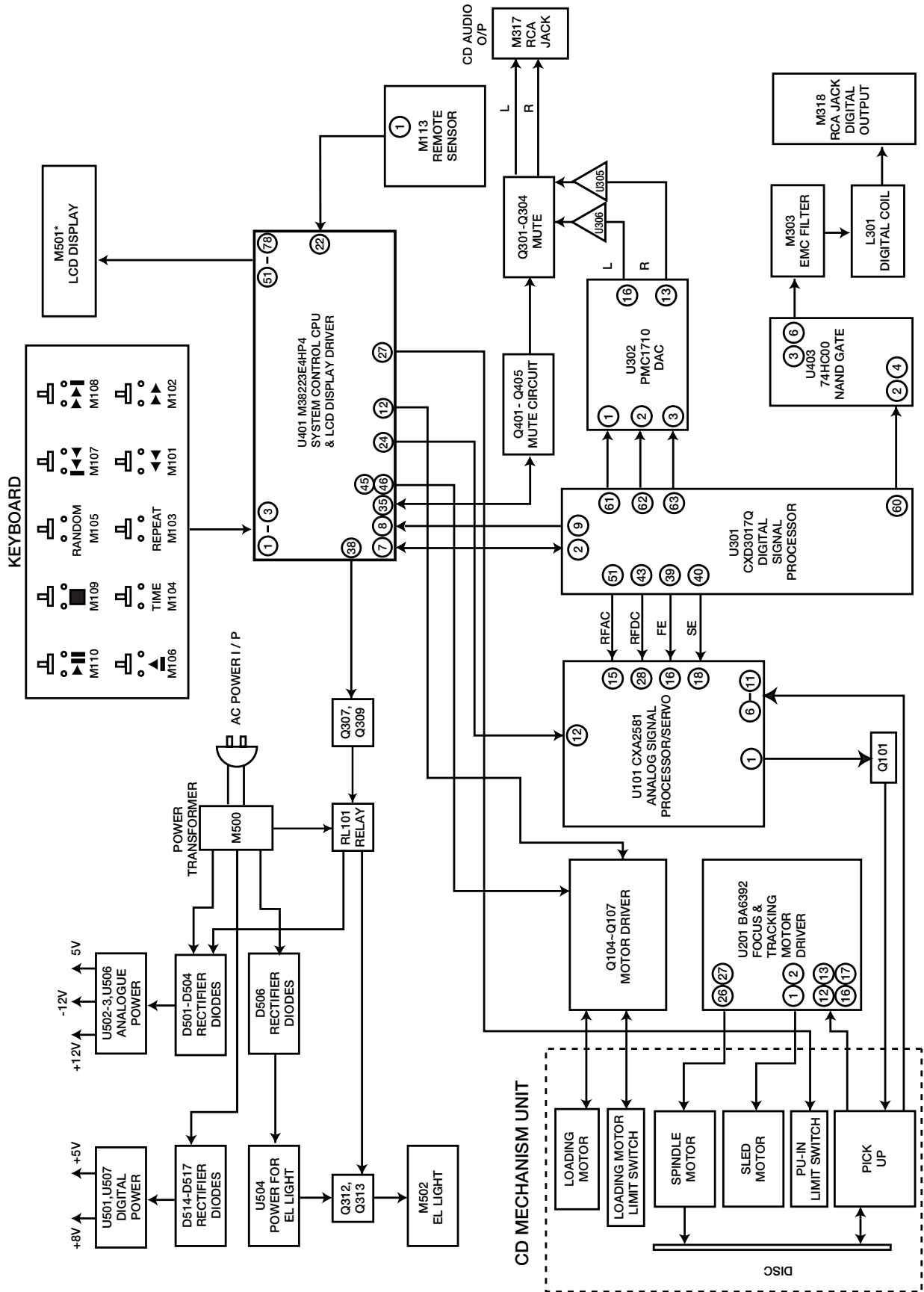

Figure No.2.

BLOCK DIAGRAM



IMPORTANT NOTES

INSTRUCTION FOR HANDLING OPTICAL SYSTEM BLOCK PICK-UP

Electrostatic breakdown of the laser diode in the optical system block may occur due to a potential difference caused by electrostatic charge accumulated on clothing, human body, etc. A ground must be provided as follows to prevent any electrostatic charge during unpacking or repair work.

1. Ground for Human Body

Be sure to wear a ground band (1M ohm) that is properly to remove any static electricity that may be charged on the body.

2. Ground for Work Bench

Be sure to place a conductive sheet (1M ohm) or copper plate with proper grounding on the work bench or other surface on which the pick-up is to be placed.

3. Because the static electricity charge on the clothing does not discharge through the body grounding band, do not let clothing to get in contact with the pick-up unit.

INCORRECT

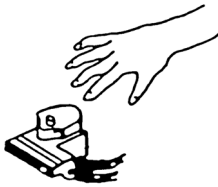

CORRECT

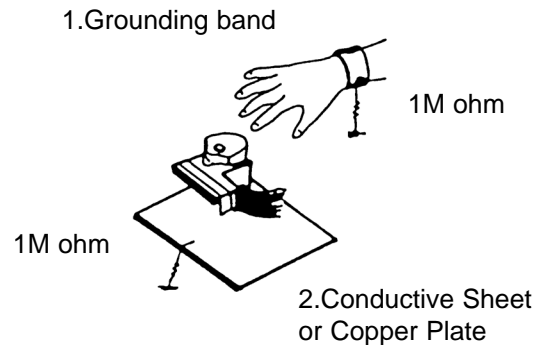

NOTE: Laser diodes are so susceptible to damage from static electricity that even if a static discharge does not ruin the diode, it can shorten its life or cause it to work improperly.

PRECAUTIONS FOR CHECKING BEAM EMISSION

The laser beam of this unit is focused on the reflecting surface of the objective lens in the optical system block. Therefore, keep your eyes at least 12 inches (30 cm) away from the objective lens when the laser diode is **ON**. (Operation Check Method for Laser Diode and Focus Search Function.)

When the **POWER** switch is turned **ON** after the chucking plate is removed, observe the objective lens and confirm that the following operations are performed properly.

(The optical system should be at the lead-in area position when it is checked at this time.)

- (1) The laser should be at the innermost position after the chucking plate is removed.
- (2) The diffused light of the laser beam can be seen when the **POWER** switch is turned **ON**.
- (3) Vertical (up and down) movement of the objective lens (2 or 3 times) will take place.

PRECAUTIONS WHEN CHANGING LASER PICK-UP

When removing the pick-up assembly, short circuit the PCB tracks on the optical block as show in the drawing in order to protect the pick-up before removal.

NOTE: Replacement pick-up assemblies are supplied with the PCB pattern already protected.

DO NOT REMOVE THE SHORT CIRCUITS UNTIL YOU HAVE FINISHED FITTING THE PICK-UP.

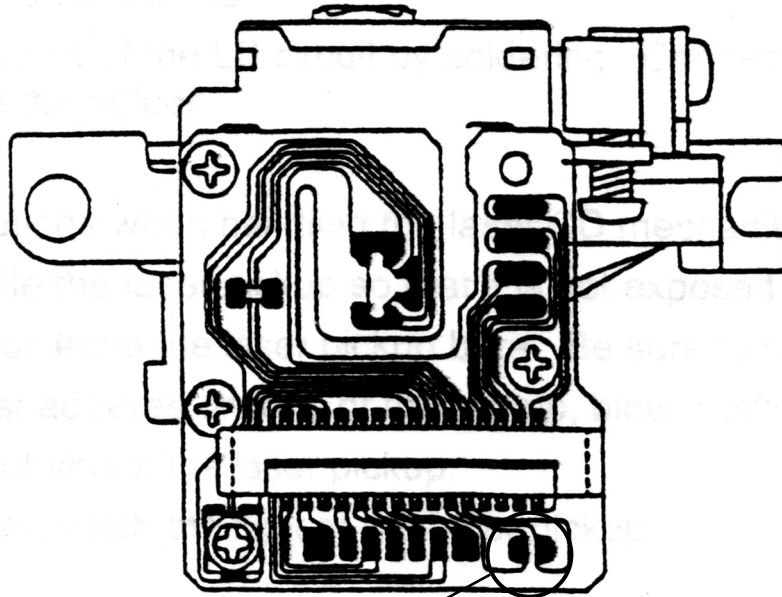

Protective soldering place
for laser diode

Caution:

Laser diodes are extremely susceptible to damage from static electricity. Even if a static discharge does not ruin the diode, it can shorten its life or cause it to work improperly. When replacing the pick-up, use a conductive mat, a grounded soldering iron, and so on, to protect the laser diode from static damage.

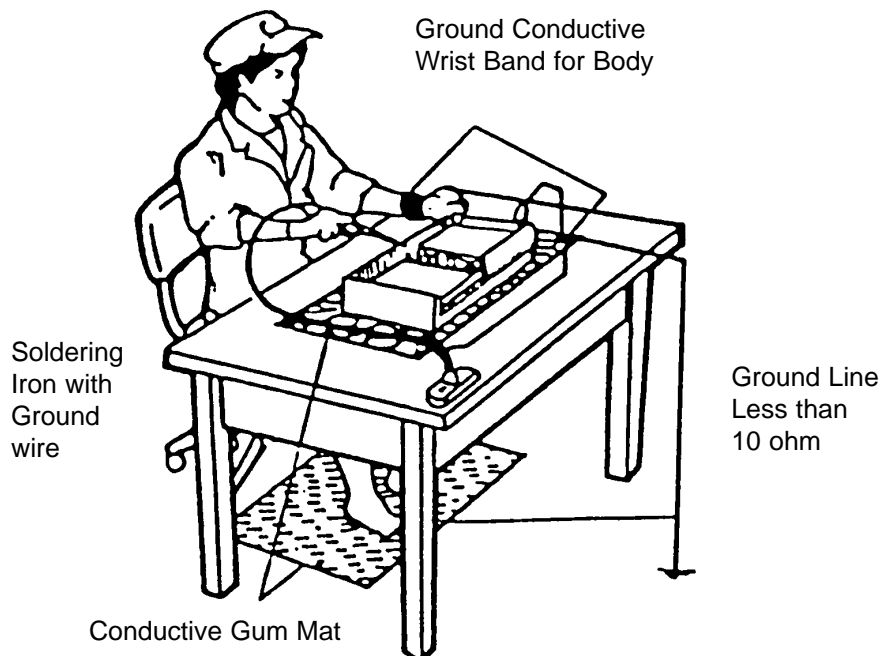

MAIN BOARD

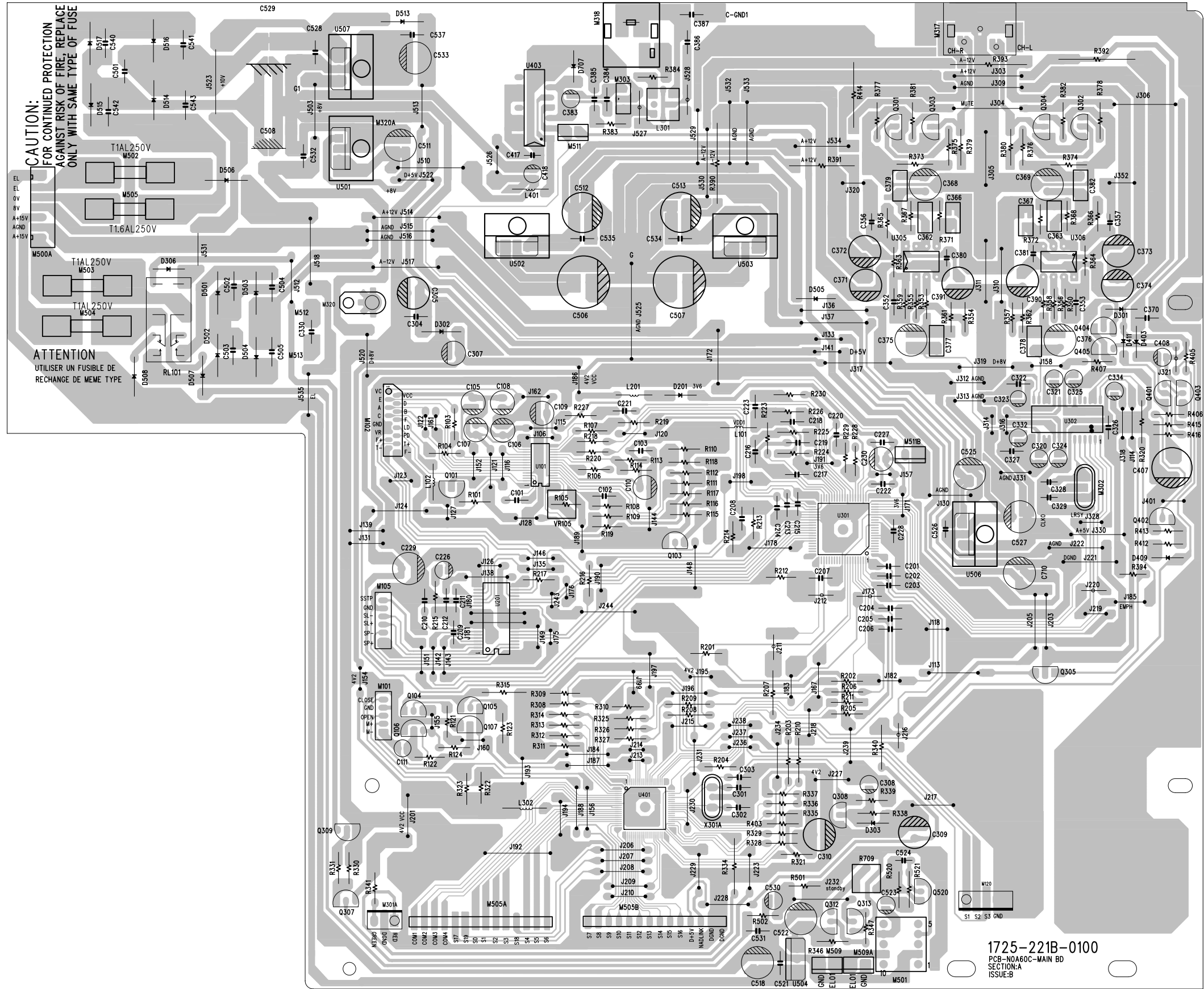

SCHEMATIC DIAGRAM

DISPLAY

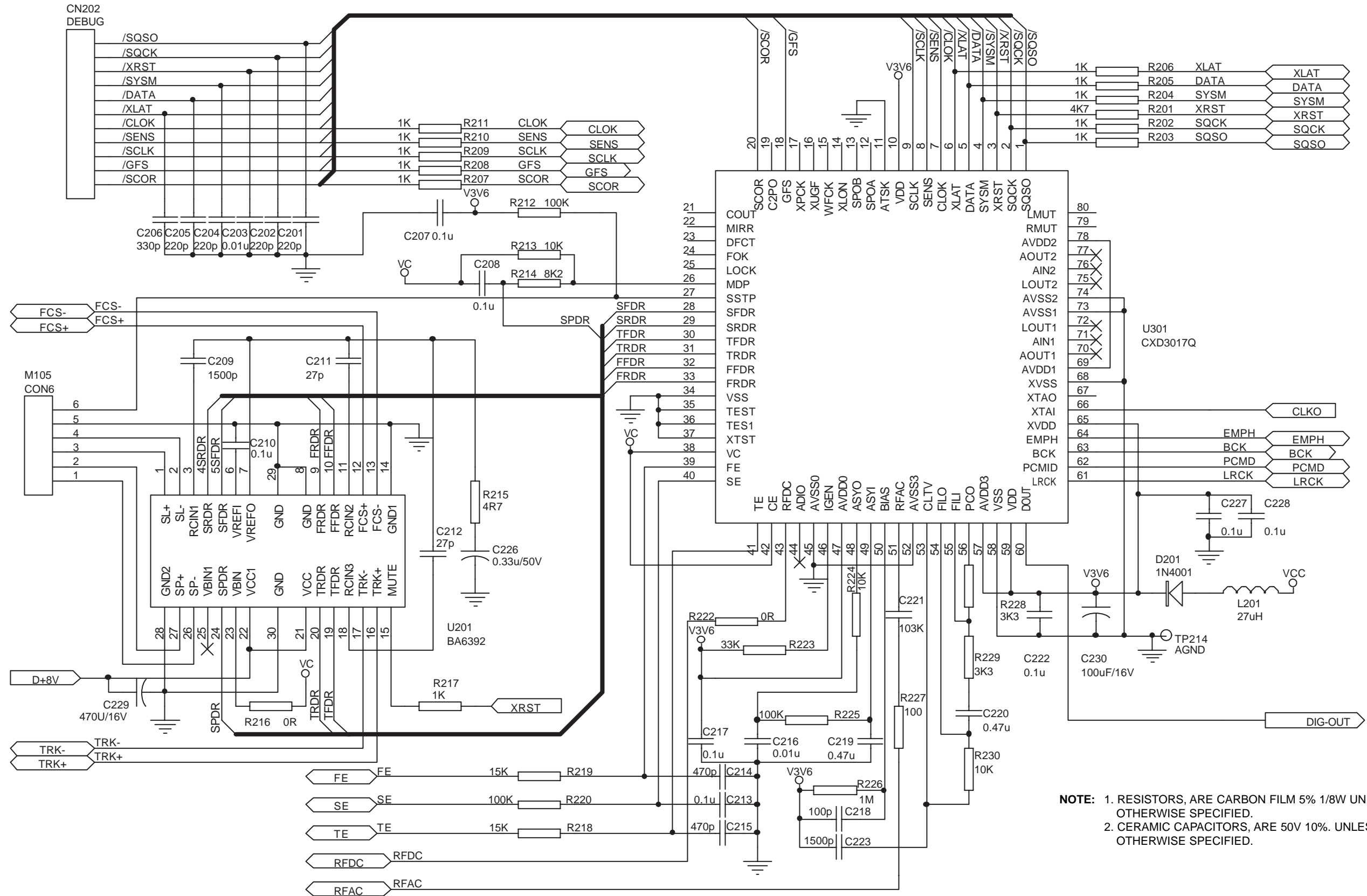

NOTE: 1. RESISTORS, ARE CARBON FILM 5% 1/8W UNLESS OTHERWISE SPECIFIED.
 2. CERAMIC CAPACITORS, ARE 50V 10%. UNLESS OTHERWISE SPECIFIED.

MCU

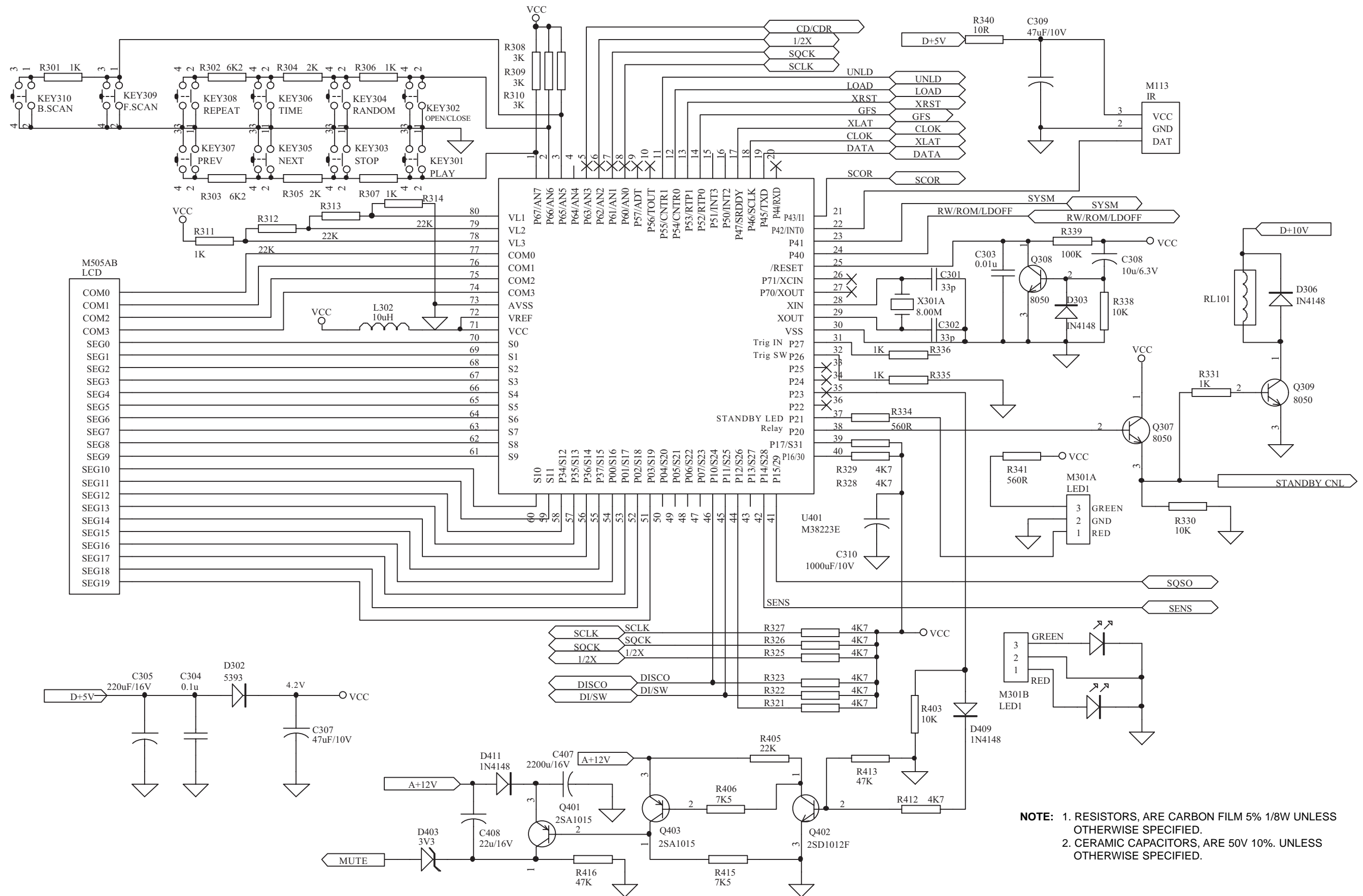

NOTE: 1. RESISTORS, ARE CARBON FILM 5% 1/8W UNLESS OTHERWISE SPECIFIED.
 2. CERAMIC CAPACITORS, ARE 50V 10%. UNLESS OTHERWISE SPECIFIED.

RF AMP

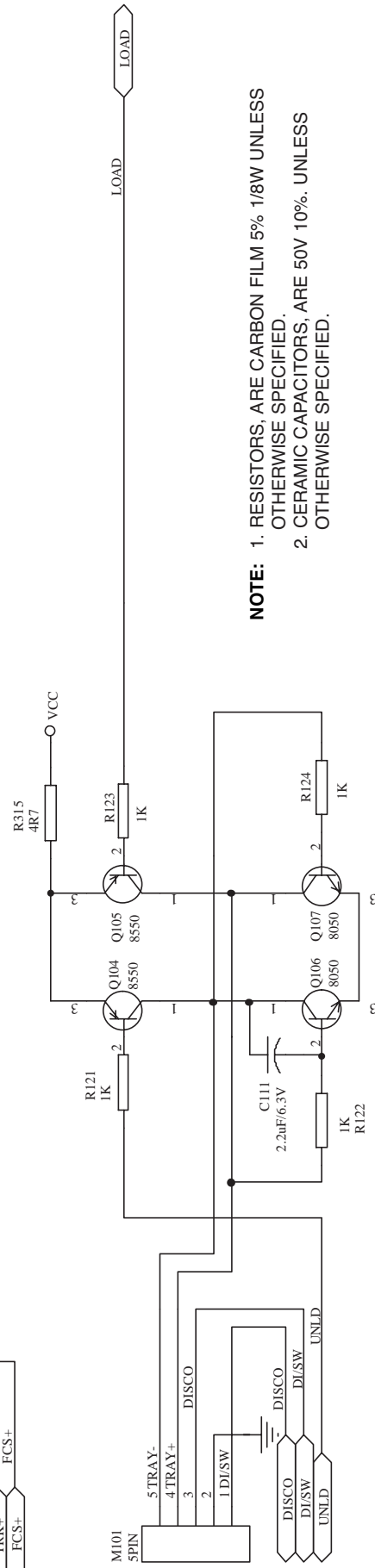
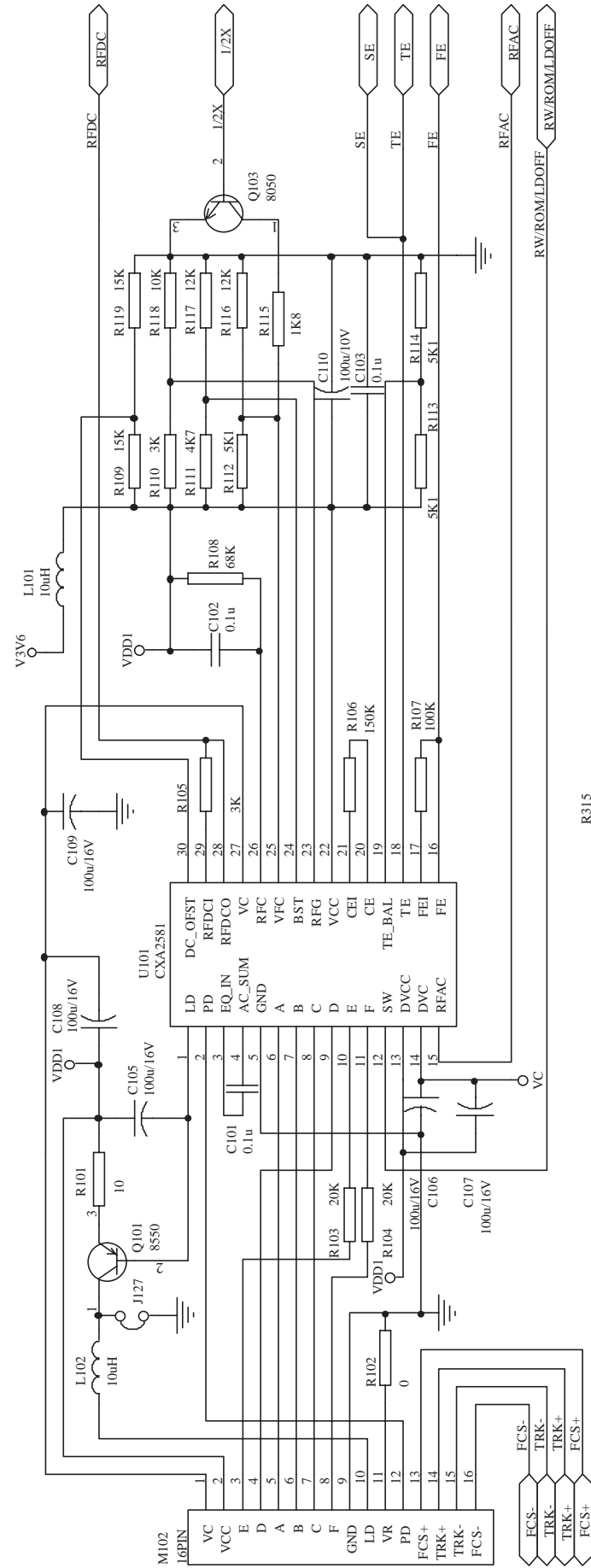

NOTE: 1. RESISTORS, ARE CARBON FILM 5% 1/8W UNLESS OTHERWISE SPECIFIED.
2. CERAMIC CAPACITORS, ARE 50V 10%, UNLESS OTHERWISE SPECIFIED.

DAC

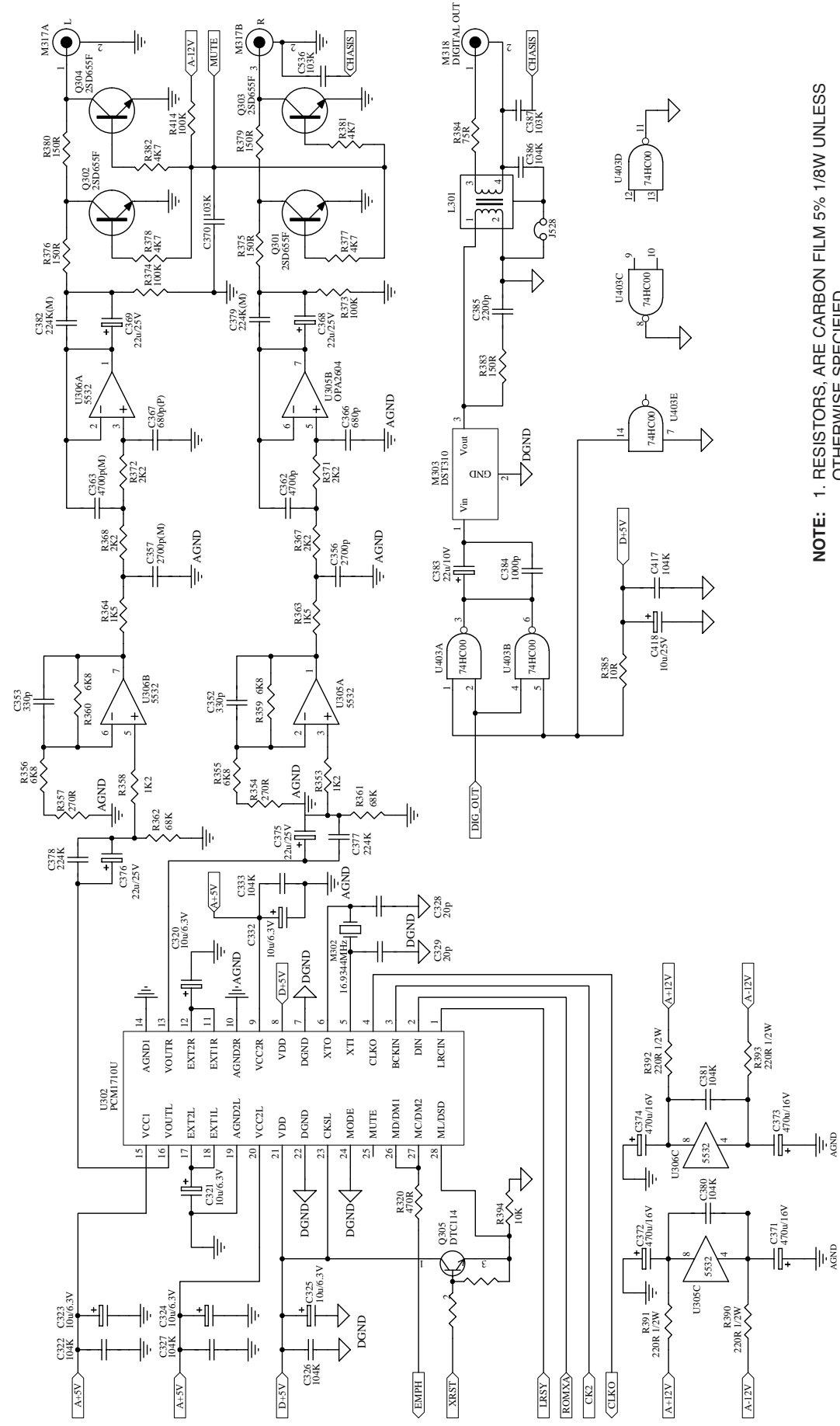

NOTE: 1. RESISTORS, ARE CARBON FILM 5% 1/8W UNLESS OTHERWISE SPECIFIED.
2. CERAMIC CAPACITORS, ARE 50V 10%, UNLESS OTHERWISE SPECIFIED.

IC BLOCK DIAGRAM

MAIN BOARD

U101: CXA2581N

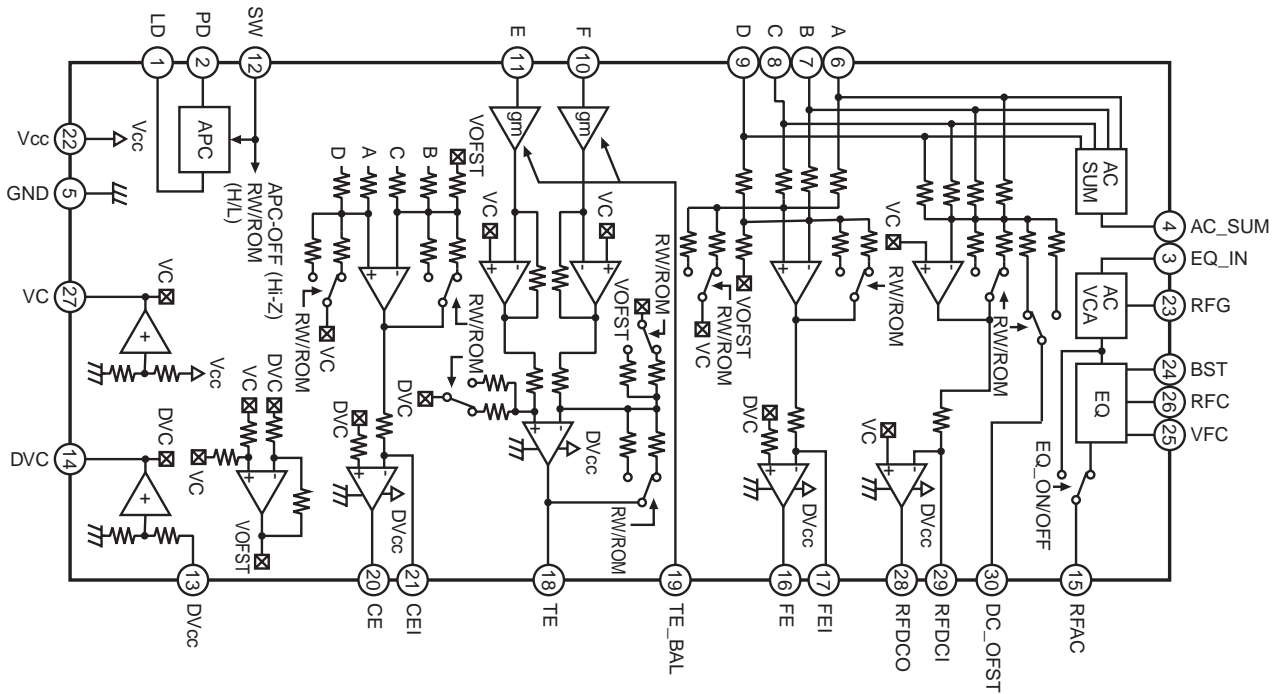

MAIN BOARD

U201: BA6392FP

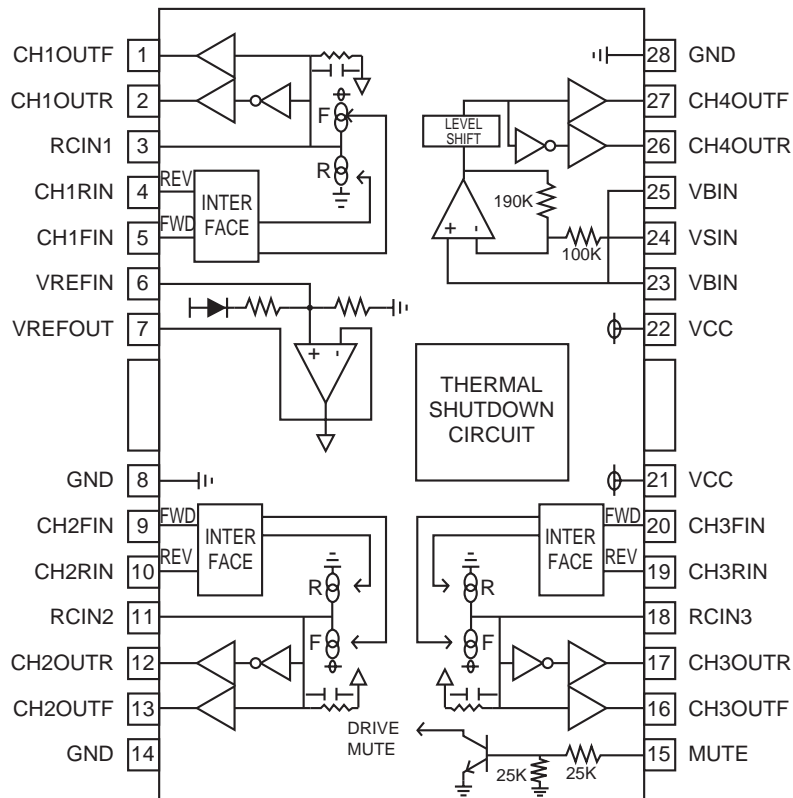

MAIN BOARD
U301: CXD3017Q

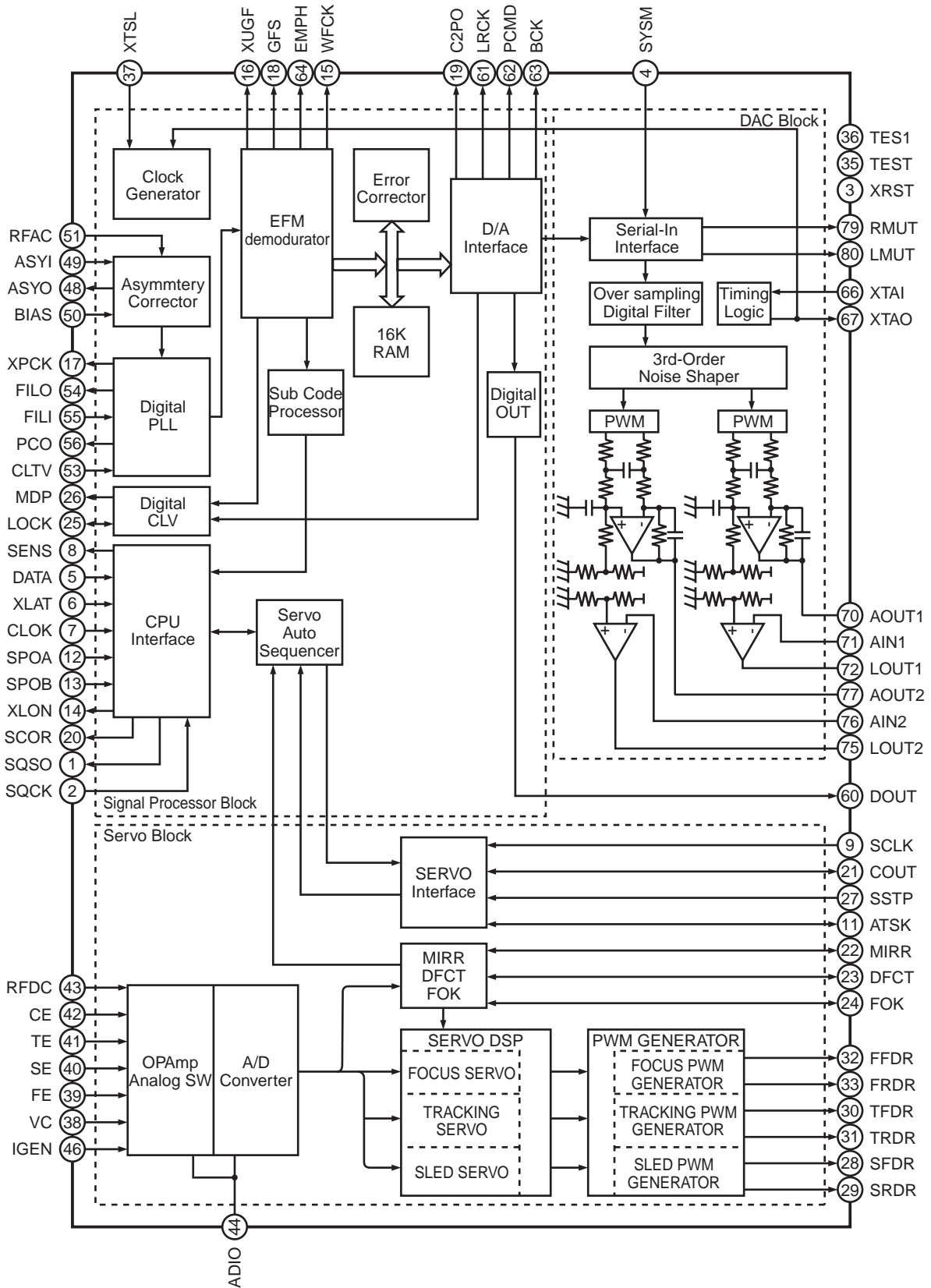

MAIN BOARD
U302: PCM1710U

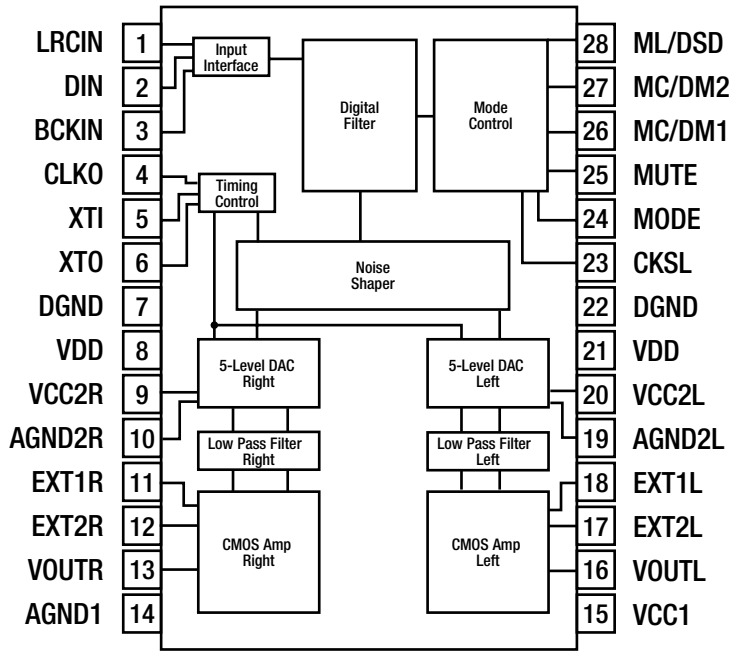

MAIN BOARD
U401: M38223E4HP4

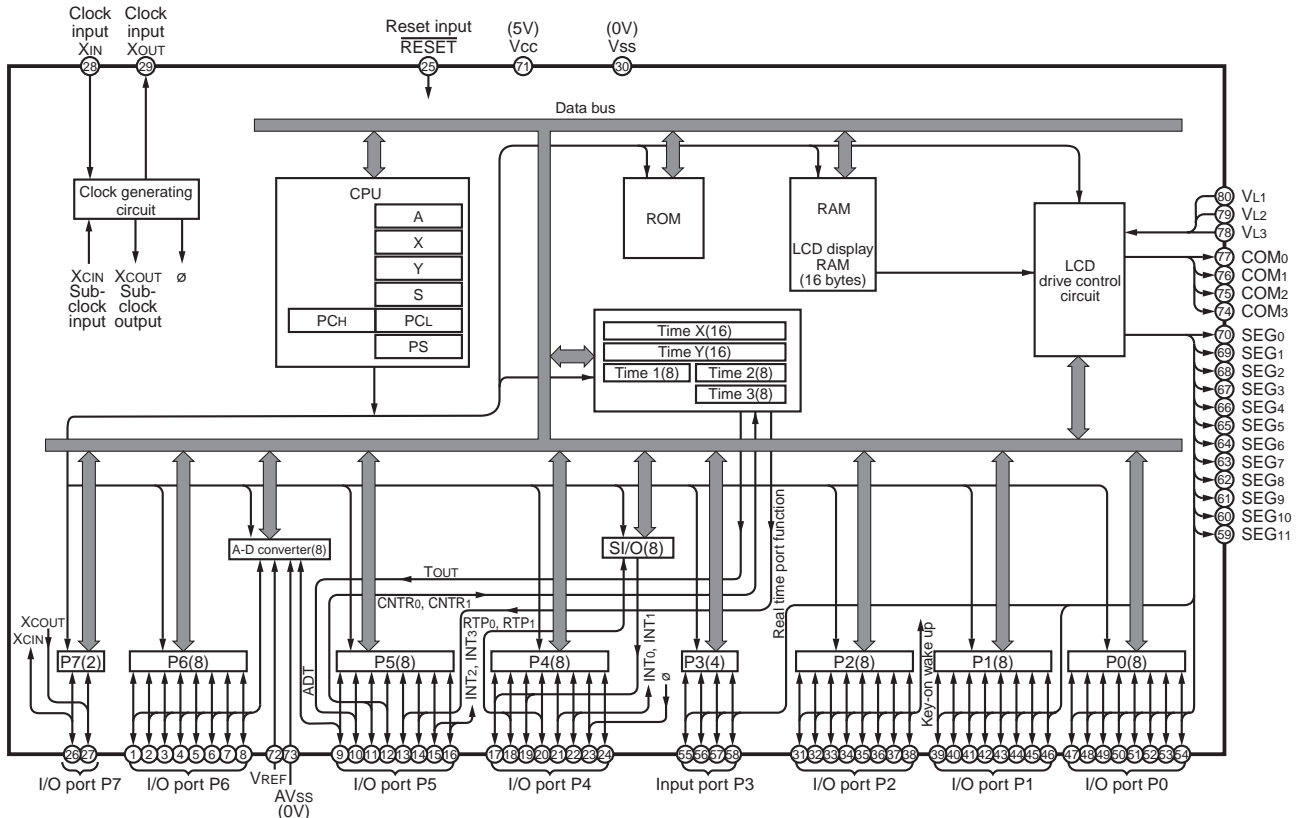

MAIN BOARD
U305, U306: NE5532

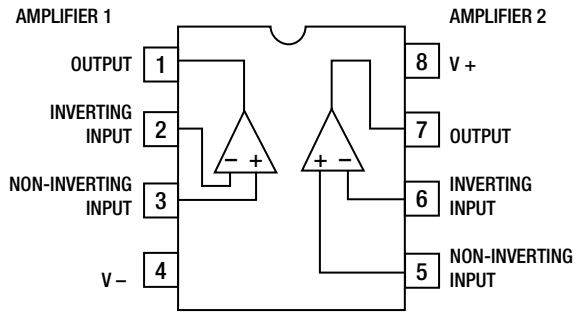

MAIN BOARD
U403: TC74HC00AP

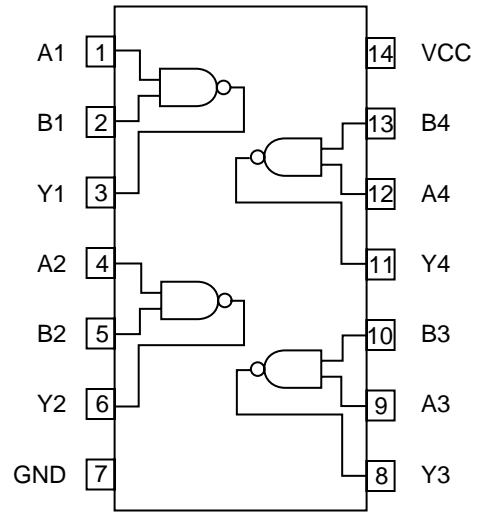

MAIN BOARD
U501, U502, U504,
U506, U507: 78XX

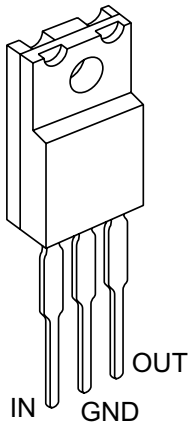

MAIN BOARD
U503: UPC79M12HF

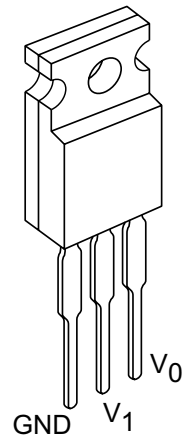

TROUBLESHOOTING GUIDE

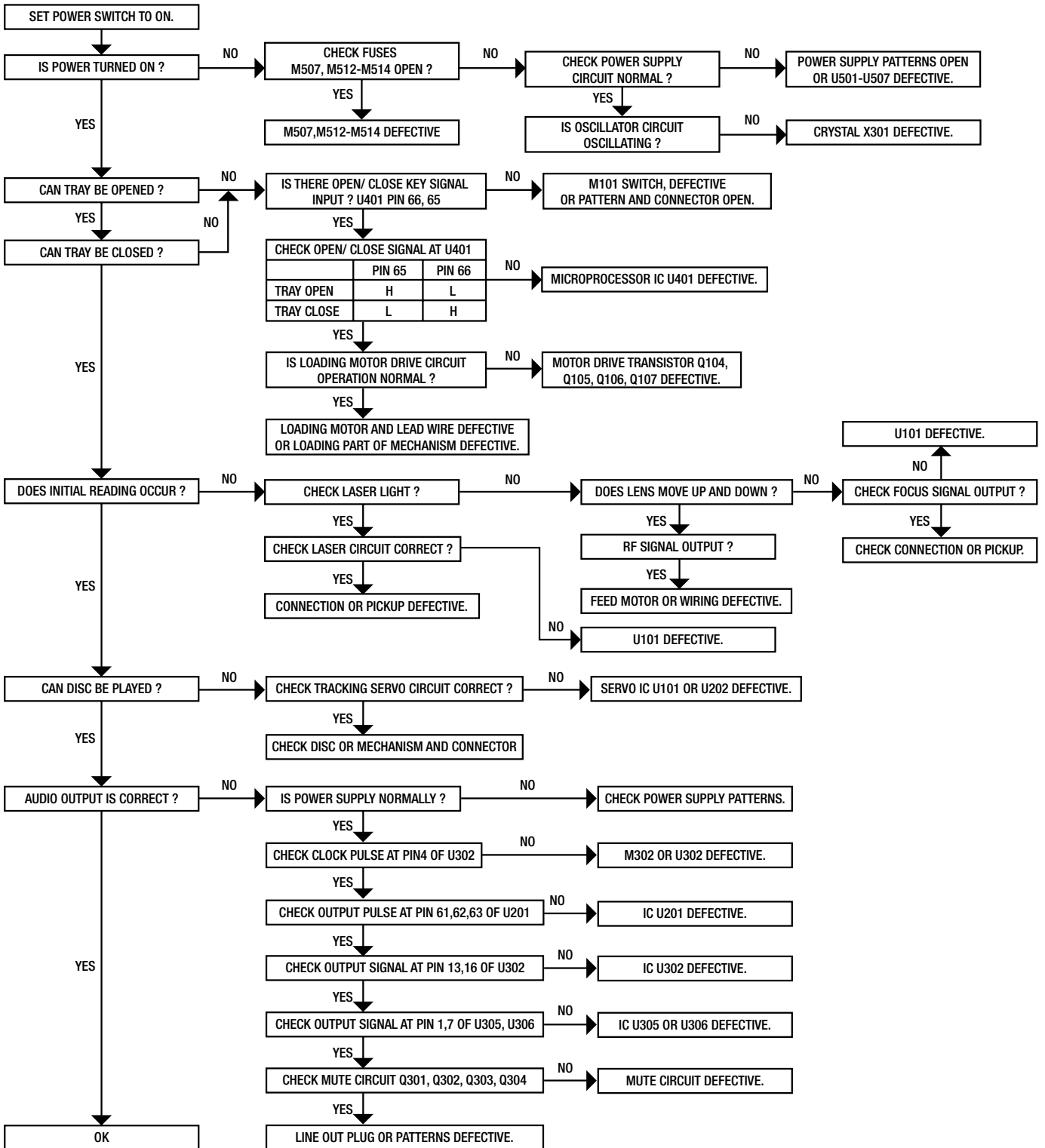

ELECTRICAL PARTS LIST

<u>Reference No.</u>	<u>Part No.</u>	<u>Description</u>
<u>DISP ASSY</u> PC BOARD	PCB-N0A60C-DISP	PCB ASSY DISP N0A60C
WIRE M505A,M505B M509A	7009-9630-0 7010-1300-1	CONN WIRE ASSY 14P 100MM CN ASSY SHIELD 2P P2.5
PC BOARD	1725-221A-0102	PCB MAIN N0A10C C521I
<u>MISCELLANEOUS</u>		
0011	4134-3011-0	LCD/EL HOLDER
0015	3716-3505-0	PC SHEET FILTER
0016	3716-3502-0	POLYESTER SHEET LEE
0017	4134-3041-0	LCD CORNER BRACKET
M113	4816-043T-3	IR SENSOR PIC-26043TM2
M501	2460-1340-2	LCD DISPLAY NEGATIVE
M502	2450-1146-0	EL BACKLIGHT
<u>KEY ASSY</u> PC BOARD	PCB-N0A60C-KEY	PCB ASSY KEY N0A60C
RESISTOR R301,R306,R307 R302,R303 R304,R305	4711-102A-2 4711-622A-2 4711-202A-2	RMF 1/8W 1K 1% AT RMF 1/8W 6.2K 1% AT RMF 1/8W 2K 1% AT
SWITCH M101-M110	5200-3538-0	SWITCH, TACT SKHHBY 7MM
WIRE M120C	7012-6347-0	CONNECTOR WIRE ASSY
PC BOARD	1725-211B-0000	PCB KEY N0A60C
<u>LED ASSY</u> PC BOARD	PCB-N0A60C-LED	PCB ASSY LED N0A60C
LED D304	3700-3517-RG	LED RED/GREEN (L-469HGW)
WIRE M301B	7703-1280-2004	CONN.ASSY 3P P2.5 L=280
PC BOARD	1725-221A-0102	PCB MAIN N0A10C C521I

Reference No.	Part No.	Description
<u>LIVE ASSY</u> PC BOARD *AH *CE	PCB-N0A60C-LIVE PCB-N0A61C-LIVE	PCB ASSY LIVE N0A60C PCB ASSY LIVE N0A61C
SWITCH M802	5200-3151-0-01	POWER SWITCH
PC BOARD	1725-221A-0102	PCB MAIN N0A10C C521I
MISCELLANEOUS C800 Δ M801,M803,M806 M804 *CE M805 *AH M810 *CE	8910-0049-0 4132-1071-0 4132-1071-0 4132-1071-0 1806-2170-0	CAP400V 4700P TERMINAL PIN TERMINAL PIN TERMINAL PIN EMI FILTER TLN12UA
<u>MAIN ASSY</u> PC BOARD	PCB-N0A60C-MAIN	PCB ASSY MAIN N0A60C
CAPACITOR C101-C103,C207,C208,C210, C213,C217,C222,C227,C228, C304,C386,C521 C105-C110,C230,C522 C111 C201,C202,C204,C205 C203,C216,C221,C303,C387 C206,C352,C353 C209,C223 C211,C212 C214,C215 C218 C219,C220 C226 C301,C302 C305 C307,C309 C308,C320,C321,C323-C325, C332,C334 C310,C508,C525 C322,C326,C327,C380,C381, C417,C501-C526,C528,C531, C532,C534,C535,C537,C540-C543 C328,C329 C330 C362,C363 C366,C367 C368,C369,C375,C376 C377-C379,C382 C383 C384	150F-104K-2-FC 157D-107M-5-IU 157F-225M-5-IUNK 150F-221K-2-FC 150F-103K-2-FC 150F-331K-5-GE 153F-152J-5-JM 15CH-270J-5-GG 150F-471K-2-FC 150F-101K-2-FC 150F-474M-5-II 157F-334K-5-IU 15CH-330J-5-IG 157D-227M-5-OMK 157C-476M-5-IU 157B-106M-5-EI 157C-108M-5-S5 157B-106M-5-EI 15CH-200J-5-GG 153F-103J-5-IM 153F-472J-5-KM 158F-681J-5-KW 157E-226K-5-IU 153F-224J-5-MIB 157C-226M-5-IU 150F-102K-2-FC	CC 50V 0.1 μ F 10% AT 3.5x2 CE 16V 100 μ F 20% RL 5x11 CE 50V 2.2 μ F 20% RL 5X11 CC 50V 220pF 10% AT 3.5x2 CC 50V 0.01 μ F 10% AT 3.5x2 CC 50V 330pF 10% RL 4x3 CM 50V 1500PF 5% RL 5.8x7 CTC 0/60 27pF 5% RL 4x4 CC 50V 470pF 10% AT 3.5x2 CC 50V 100pF 10% AT 3.5x2 CC 50V 0.47 μ F 20% RL 5X5 CE 50V 0.33 μ F 10% RL 5x11 CTC 0/60 33pF 5% RL 5x4 CE 16V 220 μ F 20% RL 8x7 CE 10V 47 μ F 20% RL 5x11 CE 6.3V 10 μ F 20% RL 3x5 CE 10V 1000 μ F 20% RL 10x16 CE 6.3V 10 μ F 20% RL 3x5 CTC 0/60 20pF 5% RL 4x4 CM 50V 0.01 μ F 5% RL 5X7 CM 50V 4700pF 5% RL 6x7 CP 50V 680pF 5% RL 6x12 CE 25V 22 μ F 10% RL 5x11 CM 50V 0.22 μ F 5% RL 7x5 CE 10V 22 μ F 20% RL 5x11 CC 50V 1000pF 10% AT 3.5x2

Reference No.	Part No.	Description
C385	150F-222K-2-GD	CC 50V 0.0022μF 10% AT
C407	157D-228M-5-X9E	CE 16V 2200μF 20% RL 12.5x20
C418,C530	157E-106M-5-IU	CE 25V 10μF 20% RL 5x11
C506,C507	157E-228M-5-X9	CE 25V 2200μF 20% RL 12.5x20
C511	157C-227M-5-KW	CE 10V 220μF 20% RL 6x12
C512,C513	157D-108M-5-S9	CE 16V 1000μF 20% RL 10x20
C518	157E-107M-5-KW	CE 25V 100μF 20% RL 6x12
C523	157F-225M-5-IU	CE 50V 2.2μF 20% RL 5x11
C524	153F-223K-5-LQ	CM 50V 0.022μF 10% RL 6.5x9
C527	157C-477M-5-OW	CE 10V 470μF 20% RL 8x12
C529	157D-338M-5-W@	CE 16V 3300μF 20% RL 12x26
C533	157D-477M-5-OY	CE 470μF +-20% RL 8X13
C536,C537	153F-272J-5-JM	CM 50V 2700PF 5% RL 5.8x7
C710	157B-107M-5-KM	CE 6.3V 100μF 20% RL 6x7
COIL		
L101,L102,L302	1801-100K-M	COIL 10μH 10% BL7.0
L201	1801-270K-M	COIL 27 μH,10%,AL,BL7
L301	1802-0450-0	DIGITAL COIL
TRANSFORMER		
M501 	1806-2320-0	TRANSFORMER STEP-UP 5V
WAFER/CONNECTOR		
M102	2101-1382-0	CONNECTOR FLEXIBLE 16P
M120	2102-051S-004	5P ST.WAFER
M301A	2102-031S-004	3 PIN ST. WAFER
M500A	2102-071S-004	WF T8 DE 7PIN COULOMB
M505A,M505B	2102-141S-004	14P ST. WAFER P=2.5
M509	2102-021S-004	2P ST.WAFER
M509A	2102-022S-008	WAFER 2PIN PITCH=2.54MM
JACK		
M318	2113-1170-0	1P RCA JACK YL AU
M317	2113-1300-0	2P RCA JACK W/R AU
CRYSTAL		
M302	2300-0110-0	CRYSTAL 16.9344 MHZ
X301	2300-1420-0	CRYSTAL 8MHZ
SCREW		
	2954-2608-3000	SCREW BT 2.6X8 BLACK
	2954-3008-0000	TAPPING 3X8MM B-TITE
IC		
U101	3131-8030-0	IC CXA2581N ASP FOR CD S
U201	3131-8040-0	IC BA6392FP 4-CHANNEL
U301	3131-8000-0	IC CXD3017Q DSP FOR CD
U302	3130-5660-0	IC PCM1710U D/A
U305,U306	3130-2430-0	IC-NE5532 OPER. AMP PHIL
U401	3131-8020-1	IC M38223M4 MICRO MASK
U403	3130-4160-0	IC TC74HC00AP DIGITAL
U501,U506	3130-2020-3	IC 7805 REG 5V 1.5A
U502	3130-2520-2	IC 7812H 12V REG, T0220F
U503	3130-3800-0	IC UPC79M12HF REGULATOR
U504	3130-9030-0	IC NJM78L09A 9V 0.1A

Reference No.	Part No.	Description
U507	3130-2790-1	IC NJM7808FA +8V REG
RELAY RL101	4500-0200-1	RELAY 2P2T BT-12S 12VDC
RESISTOR R101,R340 R103,R104 R105,R110,R308-R310 R106 R107,R212,R220,R225,R339, R373,R374,R414 R108 R109,R119 R111,R201,R321-R323,R325-R329, R377,R378,R381,R382,R412 R112,R113,R114 R115 R116,R117 R118,R213,R224,R230,R330, R338,R346,R394,R403 R121-R124,R202-R211,R217, R311,R331,R335,R347,R407 R214 R215,R315 R218,R219 R223 R225 R227 R228,R229 R312-R314,R405 R320 R334,R341 R353,R354,R357,R358 R355,R356 R359,R360 R361,R362 R363,R364 R367,R368,R371,R372 R375,R376,R379,R380,R383,R521 R384 R390-R393 R406,R415 R413,R416 R501 R502 R520	4701-100J-2 4701-203J-2 4701-302J-2 4701-154J-2 4701-104J-2 4701-683J-2 4711-153A-2 4701-472J-2 4701-512J-2 4701-182J-2 4701-123J-2 4701-103J-2 4701-102J-2 4701-822J-2 4701-4R7J-C 4701-153J-2 4701-333J-2 4701-105J-2 4701-101J-2 4701-332J-2 4701-223J-2 4701-471J-2 4701-561J-2 4711-122A-2 4711-682A-2 4701-682J-2 4711-683A-2 4701-152J-2 4701-222J-2 4701-151J-2 4701-750J-2 4717-221J-C 4701-752J-2 4701-473J-2 4711-273A-2 4701-183J-2 4701-513J-2	RCF 1/8W 10R 5% AT RCF 1/8W 20K 5% AT RCF 1/8W 3K 5% AT RCF 1/8W 150K 5% AT RCF 1/8W 100K 5% AT RCF 1/8W 68K 5% AT RMF 1/8W 15K 1% AT RCF 1/8W 4.7K 5% AT RCF 1/8W 5.1K 5% AT RCF 1/8W 1.8K 5% AT RCF 1/8W 12K 5% AT RCF 1/8W 10K 5% AT RCF 1/8W 1K 5% AT RCF 1/8W 8.2K 5% AT RCF 1/8W 4.7R 5% ATS RCF 1/8W 15K 5% AT RCF 1/8W 33K 5% AT RCF 1/8W 1M 5% AT RCF 1/8W 100R 5% AT RCF 1/8W 3.3K 5% AT RCF 1/8W 22K 5% AT RCF 1/8W 470R 5% AT RCF 1/8W 560R 5% AT RMF 1/8W 1.2K 1% AT RMF 1/8W 6.8K 1% AT RCF 1/8W 6.8K 5% AT RMF 1/8W 68K 1% AT RCF 1/8W 1.5K 5% AT RCF 1/8W 2.2K 5% AT RCF 1/8W 150R 5% AT RCF 1/8W 75R 5% AT RMF 1/2W 220R 5% ATS RCF 1/8W 7.5K 5% AT RCF 1/8W 47K 5% AT RMF 1/8W 27K 1% AT RCF 1/8W 18K 5% AT RCF 1/8W 51K 5% AT
SVR R709	4756-4716-3-06	SVR 470 H3 7X7.6 RH0615C
DIODE D201,D501-D504,D506-D508, D514-D517	4804-0010-2	DIODE 1N4001 AT

Reference No.	Part No.	Description
D301,D303,D306,D409,D411 D302,D513 D403 D505	4804-1480-2 4805-3930-2 4837-3V36-2 4840-1140-0	DIODE 1N4148 AT DIODE 1N5393 200V 1.5A DZ 1/2W +-5% 3.3V TEMIC ZD 1.3W 3.3V 5% AT
TRANSISTOR Q101,Q104,Q105,Q312,Q313 Q103,Q106,Q107,Q307-Q309,Q520 Q301-Q304 Q305,Q405 Q401,Q403 Q402 Q404	4860-0060-5 4860-0050-5 4860-1780-5 485C-114E-5 4860-0660-5 4851-012F-5 485A-114E-5	TR SS8550 C/D SAMSUNG RL TR SS8050 C/D SAMSUNG RL TR 2SD655F HFE:600-1200 TR DTC114ES TR 2SA1015 (G.R.) RL TR 2SD1012F/G HFE TR DTA114ESA ROHM
HEATSINK U501,U503,U506,U507 U502	5400-9130-0 5400-0831-0	HEAT SINK FOR 7805 2438- HEATSINK
WIRE M101 M102C M105	7012-6536-0 7012-6232-0 7012-6538-0	CONN WIRE ASSY 5PIN P2.0 WIRE CON 16P P=1.0 CONN WIRE ASSY 6PIN P2.0
PC BOARD	1725-221A-0102	PCB MAIN N0A10C C521I
MISCELLANEOUS C-GND1,M320 M303 M502-M505	2601-2608-0601 4132-1061-0 2704-0060-0 4131-9131-0	FIBRE WASHER M2.6 0.8T SOLDER TAG EMC FILTER FUSE HOLDER 6.5MM PITCH
PWR ASSY PC BOARD *AH *CE	PCB-N0A60C-PWR PCB-N0A61C-PWR	PCB ASSY PWR N0A60C PCB ASSY PWR N0A61C
TRANSFORMER M500 △	1806-2194-0	EI-57 TRANSFORMER 740
WIRE M500A	7707-1130-2004	CONN WIRE ASSY 7P P2.5
PC BOARD	1723-006A-0000	PCB-TRANSFORMER A0140C
MISCELLANEOUS J406,J407	4132-1071-0	TERMINAL PIN

- NOTE:**
- The components identified by △ mark are critical for risk of fire and electrical shock. Replace only with part number specified.
 - <*AH > : USA, Canadian model only.
 - <*C > : European model only.
 - Capacitors : CP-Polystyrene, CM-Mylar, CE-Electrolytic, CC-Ceramic, CTC-NPO.
 - Resistors : RMF-Metal Film, RCF-Carbon Film, RWR-Wirewound Metal Oxide.

MECHANISM EXPLODED VIEW

WSL-2130CCM

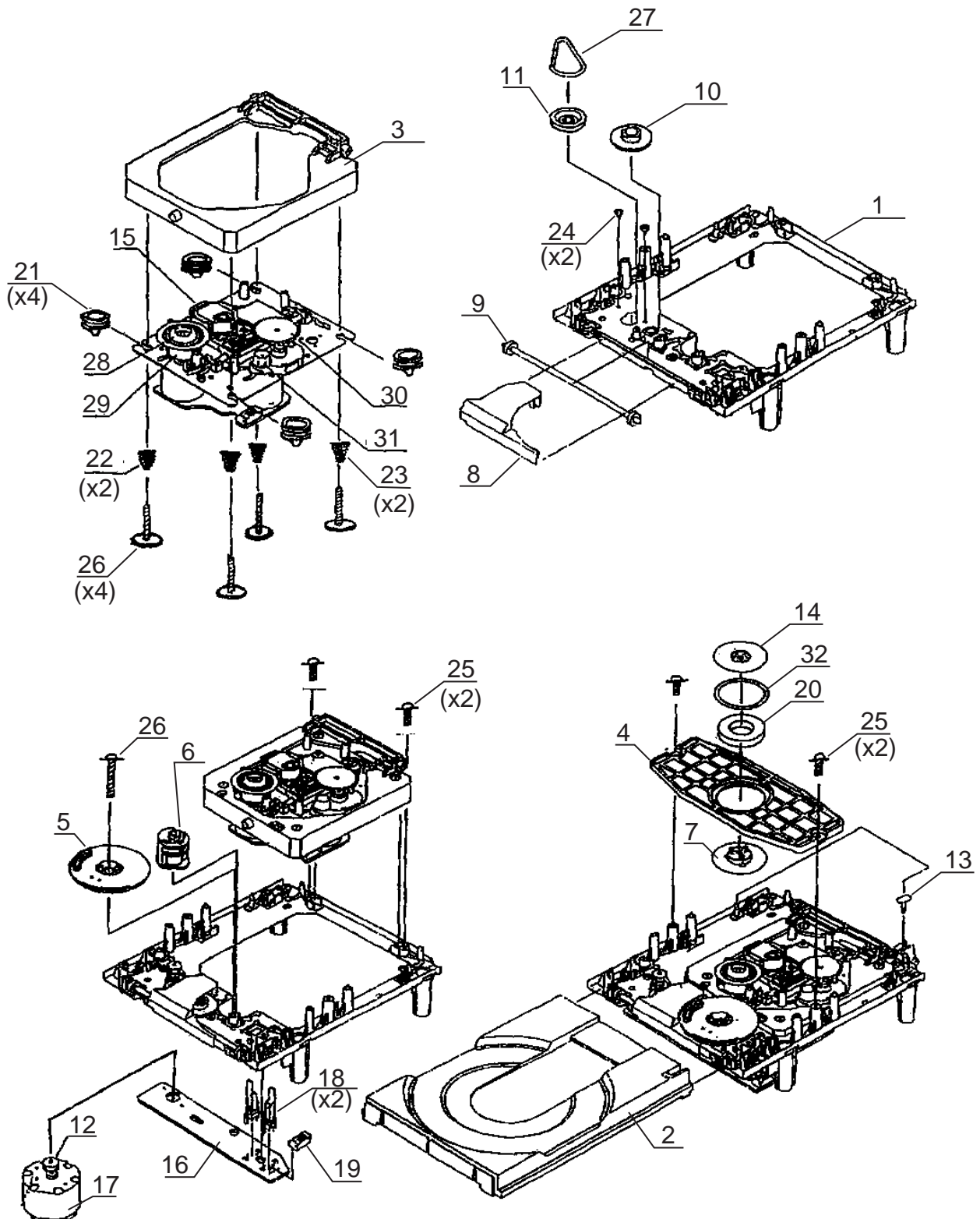

MECHANISM EXPLODED VIEW PARTS LIST

Item	Part No.	Description	Qty
1	4102-9000-0	Outside Main Chassis	1
2	4102-9001-0	Tray	1
3	4102-9002-0	Subchassis	1
4	4102-9003-0	Chucking Plate	1
5	4102-9004-0	Drive Gear	1
6	4102-9005-0	Control Cam	1
7	4102-9006-0	Chucking Pulley	1
8	4102-9007-0	Gear Cover	1
9	4102-9008-0	Tray Gear	1
10	4102-9009-0	Intermediate Gear	1
11	4102-9010-0	Loading Pulley	1
12	4102-9011-0	Motor Pulley	1
13	4102-9012-0	SW Pin	1
14	4102-9013-0	Chucking Yoke	1
15	4102-9014-0	Optical Pickup Unit	1
16	4102-9015-0	Loading PWB	1
17	4102-9016-0	Motor RF-500TB-14415	1
18	4102-9017-0	Leaf Switch	1
19	4102-9018-0	Connector pin (5P)	1
20	4102-9019-0	Magnet	1
21	4102-9020-0	Insulator	4
22	4102-9021-0	Coil Spring (Front)	2
23	4102-9022-0	Coil Spring (Rear)	2
24	4102-9023-0	Screw-Motor M2.6x2.5	2
25	4102-9024-0	Screw M2.6x7	2
26	4102-9025-0	Screw Washer Based M2.6x16	4
27	4102-9026-0	Rubber Belt	1
28	4102-9027-0	Center Ring	1
29	4102-9028-0	Turn Table	1
30	4102-9029-0	Gear (A)	1
31	4102-9030-0	Motor Gear	1
32	4102-9031-0	Damper	1

EXPLODED VIEW

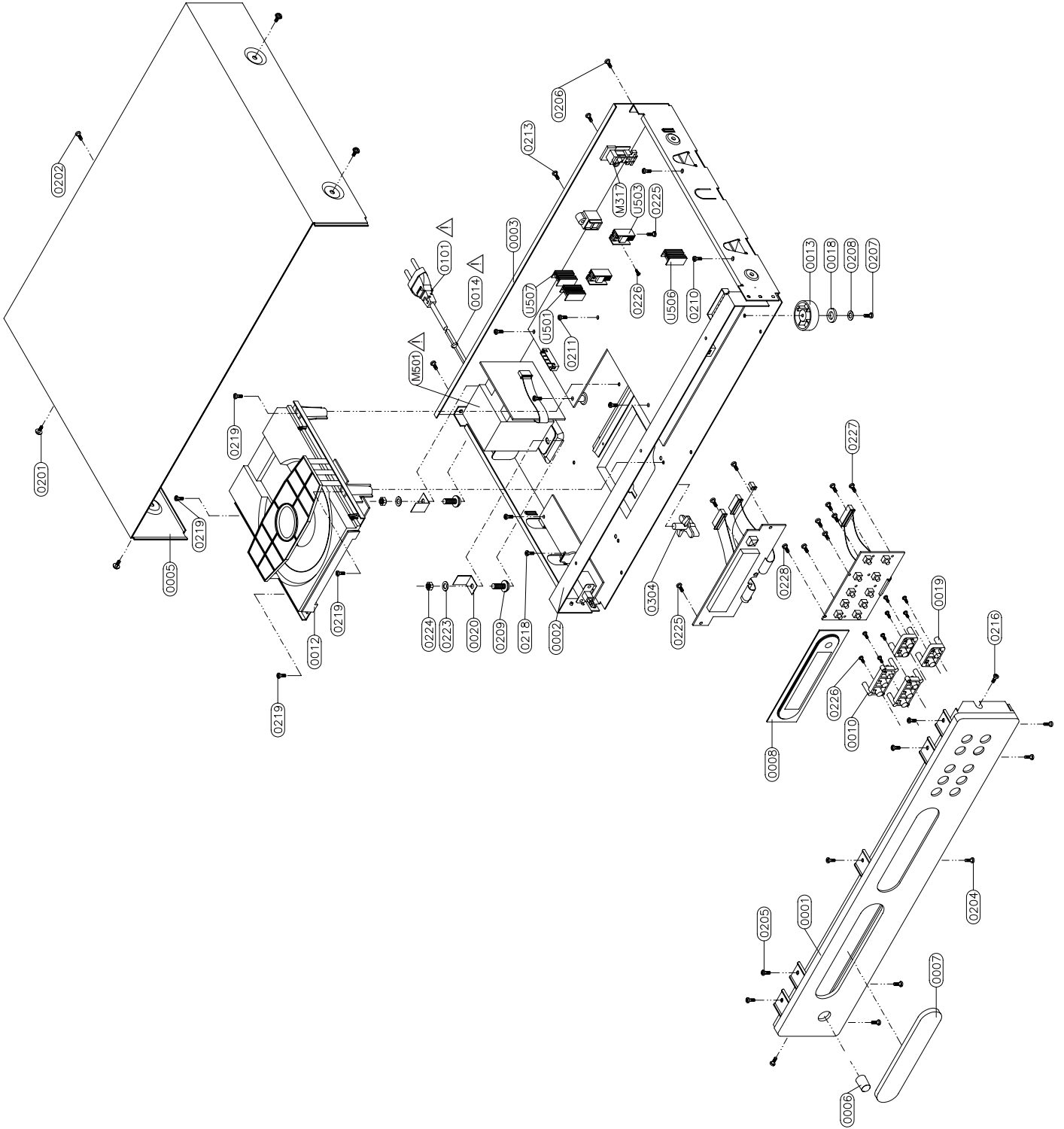

EXPLODED VIEW PARTS LIST

Item	Part No.	Description
0001 *AH TIT/*CE TIT	1466-5102-0	FASCIA SILVER (C521BEE)
0001 *AH GREY/*CE GREY	1466-5101-0	FASCIA BLACK (C521BEE)
0002	1402-3783-2	STRAP (C542)
0003 *CE GREY	1402-3525-1	CHASSIS C521BEE(C)
0003 *AH GREY/*AH TIT	1402-3524-1	CHASSIS C521BEE(AH)
0005 *AH GREY/*CE GREY	1402-3531-0	TOP COVER BLACK (C542)
0005 *AH TIT/*CE TIT	1402-3532-0	TOP COVER SILVER (C542)
0006 *AH GREY/*CE GREY	2442-1002-0	POWER BUTTON BLACK
0006 *AH TIT/*CE TIT .	2442-1001-0	POWER BUTTON SILVER
0007 *AH GREY/*CE GREY	4154-4192-1	CD DOOR BLACK (C521BEE)
0007 *AH TIT/*CE TIT	4154-4193-1	CD DOOR SILVER (C521BEE)
0008	3716-4313-0	WINDOW LENS (C520) W/SS
0010 *AH TIT/*CE TIT	2444-1202-0	BUTTON TR10 TITANIUM
0010 *AH GREY/*CE GREY	2444-1203-0	BUTTON TRIO BLACK
0013	4157-0501-1	RUBBER FOOT
0014 	4151-9461-0	STRAIN RELIEF BUSHING
0018	4152-4641-1	CUSHION FOOT W/RUBBER WA
0019 *AH GREY/*CE GREY	2444-1903-0	DUO BUTTON BLACK
0019 *AH TIT/*CE TIT	2444-1902-0	DUO BUTTON TITANIUM
0020	4132-6191-0	BRACKET,MTG,X'FORMER
0023	4154-1931-1	DUSTPROOF CUSHION
0024	3714-5706-0	LED LENS (412) CLEAR SAN
0052	4152-4841-1	BLACK CUSHION (EL/LCD)
0101 *AH GREY/*AH TIT 	7009-3100-2	AC CORD 18AWGX2
0101 *CE GREY/*CE TIT 	7009-3110-0	AC CORD (SEMKO)
0201 *AH TIT/*CE TIT	2900-4006-2010	SCM PW M4X6 RECESS WHITE
0201 *AH GREY/*CE GREY	2900-4006-3010	M4X0.5PX6MM W/FLAT
0202 *AH GREY/*CE GREY	2954-3008-3000	T3X8MM SELF TAPPING
0202 *AH TIT/*CE TIT	2954-3010-4000	ST SCREW 3X10 BH
0204	2954-3008-3000	T3X8MM SELF TAPPING
0205	2954-3008-0000	TAPPING 3X8MM B-TITE
0206	2954-3008-3000	T3X8MM SELF TAPPING
0207	2954-3008-3000	T3X8MM SELF TAPPING
0208,0217	2842-3367-0	METAL WASHER

Item	Part No.	Description
0209	2900-4010-3030	PH W/WASHER M4X10 BL ZN
0210	2954-3008-0000	TAPPING 3X8MM B-TITE
0211	2904-3006-0000	SCREW M3X6
0213	2954-3008-3000	T3X8MM SELF TAPPING
0216	2954-3008-0000	TAPPING 3X8MM B-TITE
0218	2954-3006-0000	3X6MM B-TITE (YEL.ZN)
0219	2904-3006-3000	SCREW M3X6 BINDING (BLK)
0223,0228	2600-4008-0973	FLAT WASHER M4X0.8X9.7
0224	2640-4030-0703	M4 NUT (BLK)
0225	2954-3008-0000	TAPPING 3X8MM B-TITE
0226	2954-2006-0000	TAPPING SCREW 2X6
0227	2954-2608-0000	SCREW BT 2.6X8
0230	2954-3008-0000	TAPPING 3X8MM B-TITE
0301	4151-9411-0	CUSHION 130X10X1MM
0304	1463-160B-1	CD TRANSIT LOCK (ED)
0309	3100-5101-0	PC SHEET 50X7X0.25
0311	4152-0241-0	PAD CORK 15X12X3MM GRAY
0312	4154-1401-0	PC SHEET 14x350x0.5 THK
0500 *AH GREY/*AH TIT	3000-4290-0	LABEL, BLANK 45X10
0500 *AH GREY/*AH TIT	3005-0360-2	RIBBON 60MMX600M TEC
0501	3009-1689-0	CD LASER LABEL YELLOW
0502	3000-4205-0	LABEL, CD WARNING
M501 	1806-2320-0	TRANSFORMER STEP-UP 5V

- NOTE:**
- The components identified by  mark are critical for risk of fire and electrical shock. Replace only with part number specified.
 - <*AH > : USA, Canadian model only.
 - <*C > : European model only.

PACKING DIAGRAM

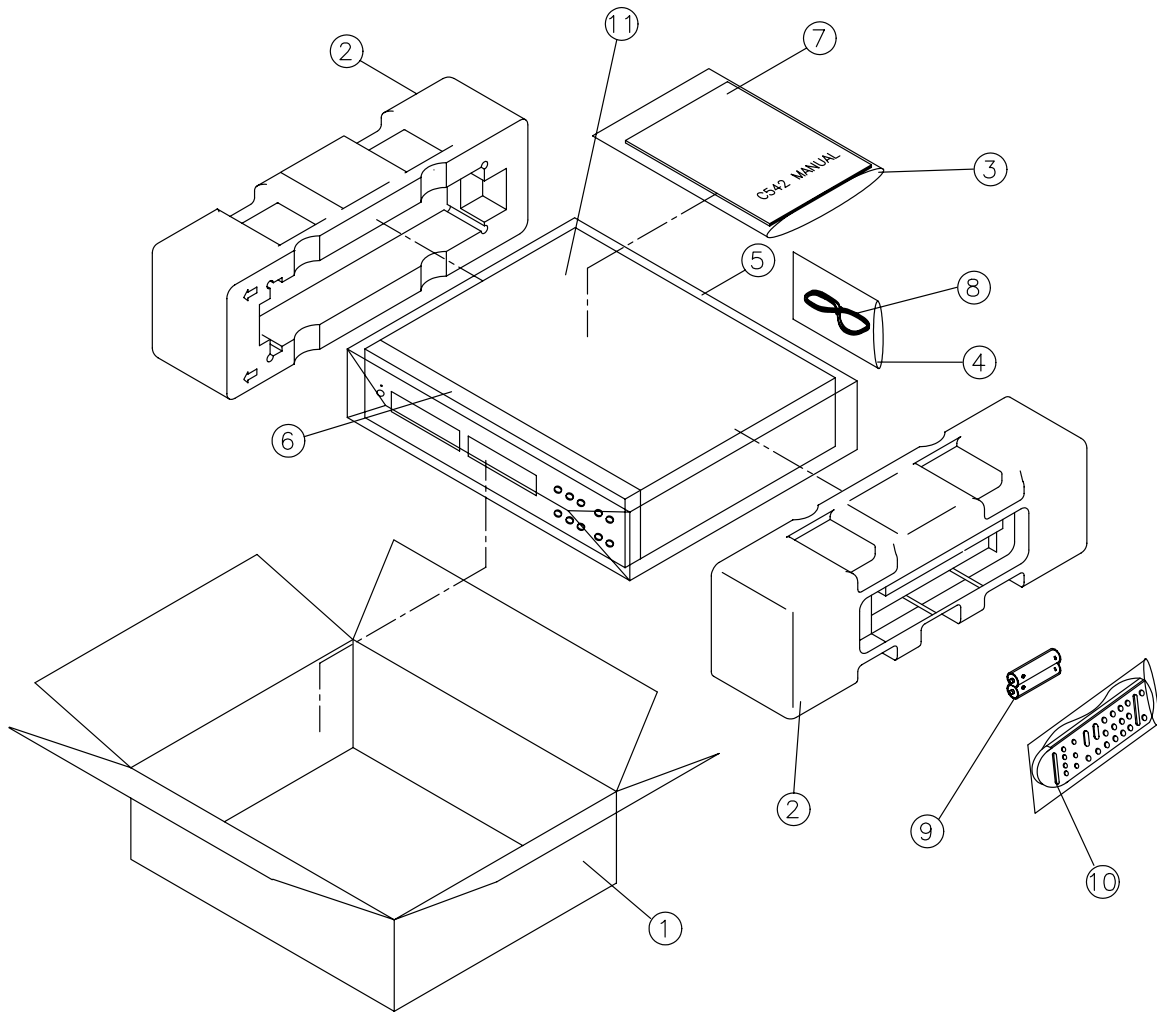

ITEM	PART NO.	DESCRIPTION	Q'TY
1.	1435-8301-0-2	CARTON BOX C521BEE	1
2.	1490-3783-2	POLYFORM ENDCAP	2
3.	1497-1062-0	POLYBAG MANUAL	1
4.	1497-1302-0	POLYBAG	1
5.	1497-1332-1	POLYBAG	1
6.	1497-1432-0	EPE BAG (412)	1
7.	4301-7071-1	INSTRUCTION MANUAL	1
8.	2103-7302-1	RCA PLUG (MALE)	1
9.	4060-0530-0	GREENCELL 3A SIZE GP24G2	2
10.	8912-0038-0	REMOTE CONTROL C521BEE	1
11.	1405-2520-0	WHITE PAPER	1

Proprietary information for servicing purposes only. The information herein may not be used commercially without the prior written agreement of NAD Electronics International, Toronto, Canada.