

BIPOLAR ANALOG INTEGRATED CIRCUIT

μ PC1237

PROTECTOR IC FOR STEREO POWER AMPLIFIER

DESCRIPTION

μ PC1237 is a monolithic integrated circuit designed for protecting stereo power amplifiers and loudspeakers.

FEATURES

- Work stably within a wide power supply voltage range. ($V_{CC} = 25$ to 60 V)
- Contain a relay driver. (Max. $I_G = 80$ mA)
- Work as either latching function or automatic resetting function by using pin 3. (In both overload detection and output offset detection, either function can be selected.)
- Need only single power supply.
- Both positive and negative output offset can be detected through the same pin. (Output offset detection through pin 2)
- AC voltage can be detected. (For AC-power-OFF mute through pin 4)
- The time delay from amplifier power ON to relay ON can be freely set by selecting external components. (For AC-power-ON mute through pin 7)
- The moment that amplifier-power is turned off, it can make relay broken OFF and then loudspeaker disconnected from amplifier to prevent a shock off noise.

ORDERING INFORMATION

PART NUMBER	PACKAGE	QUALITY GRADE
μ PC1237HA	8 PIN PLASTIC SLIM SIP	Standard

Please refer to "Quality grade on NEC Semiconductor Devices" (Document number IEI-1209) published by NEC Corporation to know the specification of quality grade on the devices and its recommended applications.

BLOCK DIAGRAM

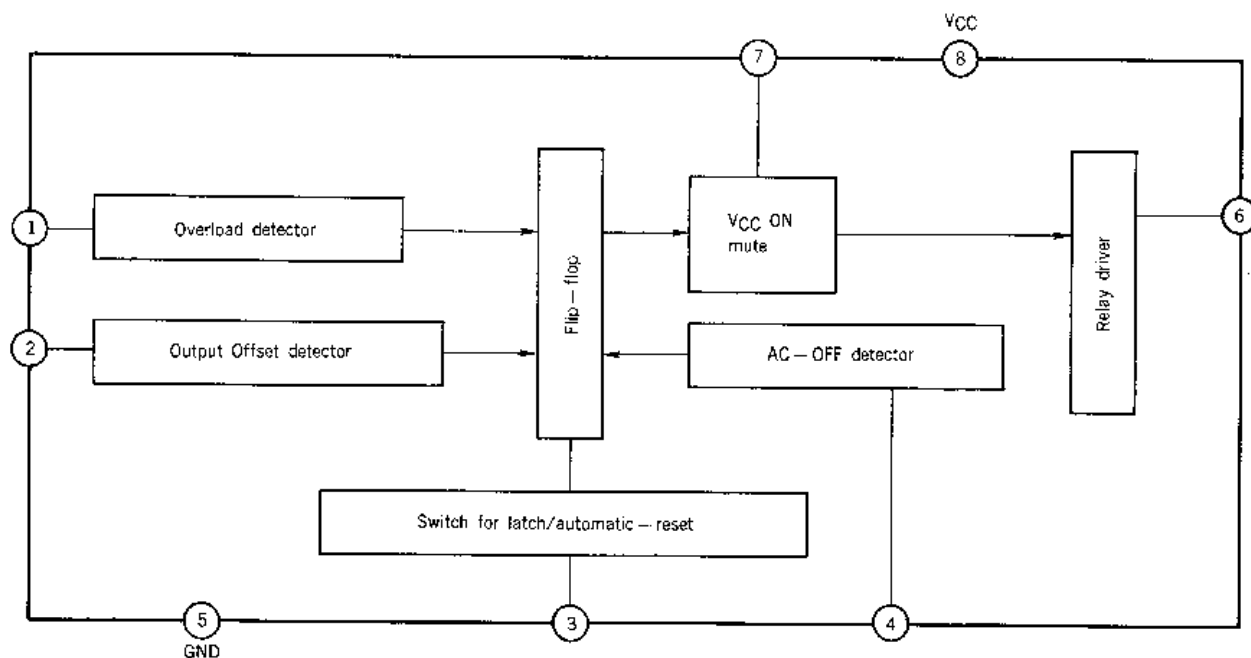

ABSOLUTE MAXIMUM RATINGS ($T_a = 25^\circ\text{C}$)

Power Supply Voltage	V_{CC}	60	V
Allowable Power Dissipation	P_D	320*	mW
Operational Temperature	T_{opt}	-20 to +75	$^\circ\text{C}$
Storage Temperature	T_{stg}	-40 to +125	$^\circ\text{C}$
Pin 6 Maximum Current	$I_6 \text{ max}$	80	mA
Pin 4 Maximum Voltage	$V_4 \text{ max}$	10	V
Pin 8 Maximum Voltage	$V_8 \text{ max}$	8	V
Pin 1 Maximum Current	$I_1 \text{ max}$	3	mA
Pin 2 Maximum Current	$I_2 \text{ max}$	± 3	mA
Pin 7 Maximum Voltage	$V_7 \text{ max}$	8	V

* $T_a = 75^\circ\text{C}$ **RECOMMENDED OPERATING CONDITION**Supply Voltage $V_{CC} = 25$ to 45 to 60 V**ELECTRICAL CHARACTERISTICS ($V_{CC} = 45\text{ V}$, $T_a = 25^\circ\text{C}$, State using latching function)**

CHARACTERISTIC	SYMBOL	MIN	TYP.	MAX.	UNIT	CONDITION
Pin 1 Threshold Voltage	$V_{th\ 1}$	0.58	0.67	0.76	V	level to invert at pin 6
Pin 2 Positive Threshold Voltage	V_{th+2}	0.54	0.62	0.70	V	level to invert at pin 6
Pin 2 Negative Threshold Voltage	V_{th-2}	-0.12	-0.17	-0.23	V	level to invert at pin 6
Pin 4 Threshold Voltage	$V_{th\ 4}$	0.60	0.74	0.90	V	level to invert at pin 6
Pin 8 Reference Voltage	V_8	3.0	3.4	3.8	V	$R_L = 1.5\text{ k}\Omega$

TEST CIRCUIT (State using latching function)

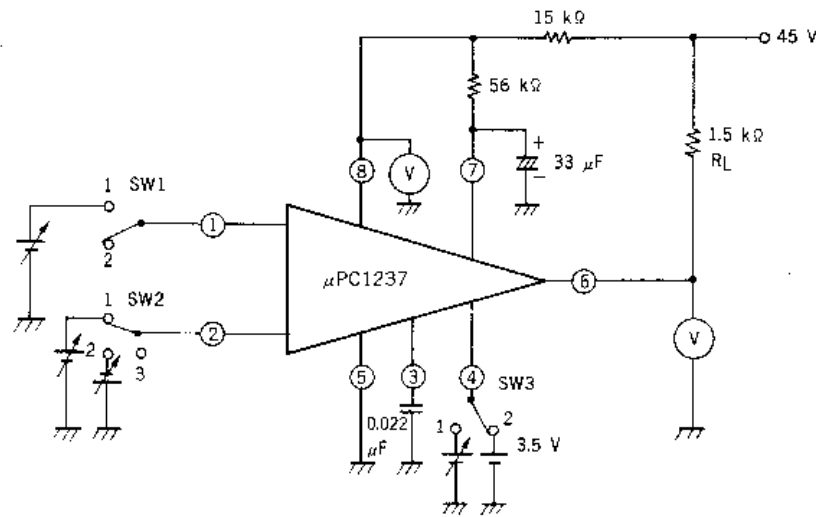

Switch positions

Item	SW 1	SW 2	SW 3
Vth 1	1	3	2
Vth+2	2	1	2
Vth-2	2	2	2
Vth 4	2	3	1
VB	2	3	2

TYPICAL APPLICATION CIRCUIT

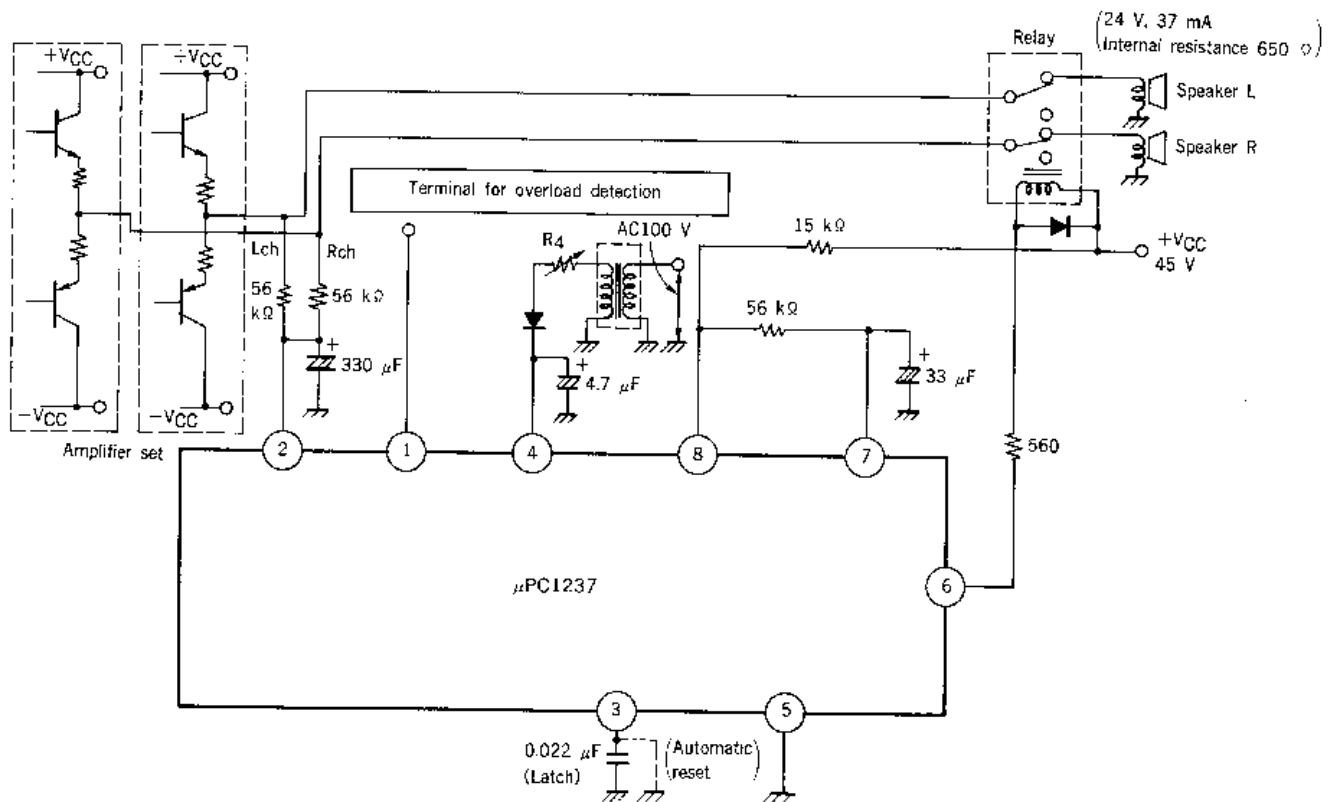

NOTE FOR USING μPC1237

1. FUNCTION FOR OUTPUT OFFSET DETECTION (pin 2)

1) If too much DC current flows through a speaker voice coil due to large output offset DC level, the voice coil might be overheated and the speaker might be broken. To prevent the damage, it is necessary to detect the Output Offset DC level and to disconnect the speaker from the power amplifier by breaking off a relay if the detected DC level is shifted beyond a threshold level. μPC1237 has a function to detect both the positive and the negative Output Offset DC level with its single power supply. As shown below, you can easily make the positive and the negative threshold level equivalent and also set up their level by choosing proper resistances.

2) How to determine the threshold levels of Output Offset detection. (±Vth)

[1] The threshold level of positive output offset detection (+Vth) is given by Eq. (1).

$$+V_{th} = \left(2 + \frac{R_A}{R_C}\right) \cdot V_{th}^{+2}, \dots\dots\dots (1)$$

where V_{th}^{+2} is the original positive threshold level of pin 2, and $V_{th}^{+2} = 0.62 \text{ V TYP.}$

[2] The threshold level of negative Output Offset detection (-Vth) is given by Eq. (2).

$$-V_{th} = - \left\{ -V_{th}^{-2} \cdot \left(2 + \frac{R_A}{R_C}\right) + I_{c2} \cdot R_A \right\}, \dots\dots\dots (2)$$

where V_{th}^{-2} is the original negative threshold level of pin 2, and $V_{th}^{-2} = -0.17 \text{ V TYP.}$

and I_{c2} is the current from μPC1237 and, $I_{c2} = 12.5 \mu\text{A TYP.}$
at nearly -Vth.

3) You can easily find how to make ±Vth level equivalent as shown below

$$\left(2 + \frac{R_A}{R_C}\right) \cdot V_{th}^{+2} = - \left\{ -V_{th}^{-2} \cdot \left(2 + \frac{R_A}{R_C}\right) + I_{c2} \cdot R_A \right\}, \dots\dots\dots (3)$$

therefore determine R_A , R_B and R_C from Eq. (3)

Attention; The original positive and negative threshold level at pin 2 without any resistances are unbalanced; $+V_{th} = 0.62 \text{ V TYP.}$ and $-V_{th} = -0.17 \text{ V TYP.}$

Example of design

If you need the output offset threshold level ±Vth to be ±2.0 V, determine R_A , R_B and R_C as shown below.

[1] Substitute 2.0 to +Vth in Eq. (1) and obtain R_A / R_C .

$$2.0 = \left(2 + \frac{R_A}{R_C}\right) \times 0.62$$

$$\frac{R_A}{R_C} = 1.226$$

[2] Substitute -2.0 to -Vth in Eq. (2) and obtain R_A (R_B) and R_C .

$$-2.0 = -0.17 \left(2 + 1.226\right) - 12.5 (\mu\text{A}) \times R_A (\text{k}\Omega) (\text{V})$$

$$R_A = 116.1 \text{ k}\Omega$$

$$R_C = 94.7 \text{ k}\Omega$$

Therefore, if you need ±Vth to be 2.0 volts, choose R_A , R_B and R_C as shown below.

$$R_A = R_B = 120 \text{ k}\Omega \text{ and } R_C = 91 \text{ k}\Omega$$

The lower limits of R_A and R_B are given by the maximum rating (±3 mA) of pin 2 and

$$\frac{\pm V_{CC}}{R_{A(B)}} < \pm 3 (\text{mA})$$

In case of recommended condition, that is $R_A = R_B = 56 \text{ k}\Omega$ and $R_C = \infty$, ±Vth can be obtained as shown below.

$$[1] +V_{th} = \left(2 + \frac{56 (\text{k}\Omega)}{\infty}\right) \cdot 0.62 = 1.24 (\text{V})$$

$$[2] -V_{th} = -0.17 \left(2 + \frac{56 (\text{k}\Omega)}{\infty}\right) - 12.5 (\mu\text{A}) \times 56 (\text{k}\Omega) = -1.04 (\text{V})$$

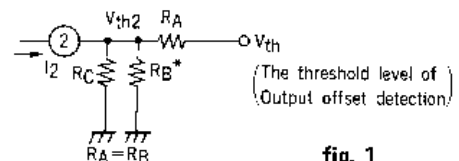

* Rch power amplifier output terminal is usually an imaginably GND as seen from Lch power amplifier, so that the equivalent circuit can be obtained as shown above.

2. FUNCTION OF AC LEVEL DETECTION

When you turn off the power switch, it sometimes causes a shock-off noise, therefore it is necessary to break off the relay and then to keep the power amplifier apart from loud speaker at the moment that power switch is turned off. In other words, the protection circuit is required to have a function to detect that power-off time. However, in fact, it is difficult to detect that power-off time from actual DC supply voltage line. Because it cannot be turned 0 V instantaneously due to a large capacitance inserted between the power supply line and GND. In case of μPC1237, it can detect this power-off time from AC power supply directly, that is, this is a function to detect AC level.

The AC power supply level (usually 50 Hz or 60 Hz) can be transmitted to pin 4 through a half-wave rectification circuit as shown below.

And it works within a wide range of AC level by choosing a proper resistance as R4 (Refer to the characteristic curve shown as fig.5 for the choice of R4). If power switch is turned off while the relay is being made ON and the speaker is being connected to the power amplifier output, the relay will be broken OFF to disconnect the speaker after a time delay (AC OFF mute) according to the discharge time constant determined by the voltage on pin 4, the external capacitance C4, and the internal resistance of the IC.

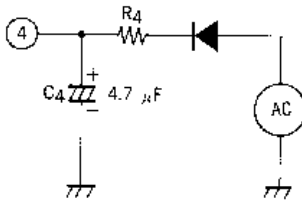

fig. 2

3. FUNCTION OF OVERLOAD DETECTION (pin 1)

The original threshold level of pin 1 is 0.67 V TYP. In case of using a constant-current drive, as the means of detection, the threshold current level is 110 μA TYP. When current which is larger than 110 μA flows to the IC, the relay will be broken OFF.

Note ; The overload detecting circuit is not included in the IC because of patent problems. Use the external circuit as an overload detection.

4. FUNCTION OF LATCHING AND AUTOMATIC RESETTING (pin 3)

If the IC detects the abnormal condition such as the larger output offset level or the overload, the IC can make the relay broken OFF. And then, two functions can be selected after the condition returns to the normal state. One is that the relay is made ON automatically and the other is that it keeps the relay broken off until once the power switch is turned off and then is turned on again.

The former is a function of automatic resetting and the latter is a function of latching. μPC1237 has both functions and can be selected either function by using pin 3. In case of latching, connect pin 3 to the ground through the capacitor, which is for preventing misoperation. For automatic resetting, connect it to the ground directly. This function is valid for both overload detection and output offset detection.

5. TIME DELAY FROM POWER AMPLIFIER POWER SWITCH ON TO RELAY ON (power-on mute at pin 7)

To suppress shock-on noise generated by power ON, a time delay is provided by connecting a circuit with a time constant. This time delay is set to make relay ON to connect speakers after enough time for the power amplifier and the preamplifier to reach a stable operating condition. The ON mute time is determined as follows,

$$T \text{ (ON mute)} = -C_7 \cdot R_7 \cdot \ln \frac{V_8 - V_7}{V_8}$$

where V_8 is reference voltage at pin 8, 3.40 volts, TYP. and V_7 is threshold level at pin 7, 2.06 volts, TYP.

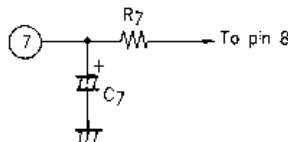

fig. 3

6. HOW TO MAKE IT WORK WITHIN A WIDE RANGE OF POWER SUPPLY VOLTAGE (pin 8)

By choosing a proper resistance R_8 connected to pin 8, the IC can work within a wide range of power supply voltage V_{CC} from 25 to 60 volts.

In case that pin 8 is directly driven by a regulated power supply, set V_8 to 3.40 volts, TYP. As for the choice of R_8 value, refer to the characteristic curve shown as fig.6.

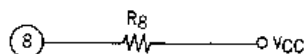

fig. 4

fig. 5 OPTIMUM VALUE OF EXTERNAL RESISTANCE R_4

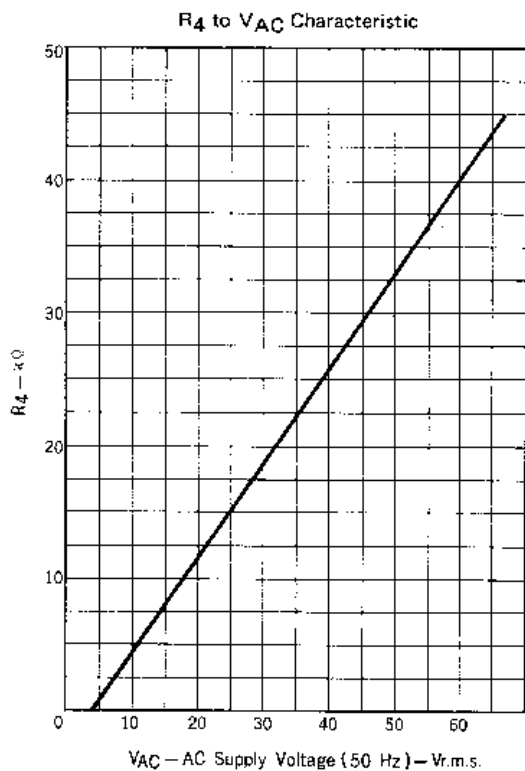
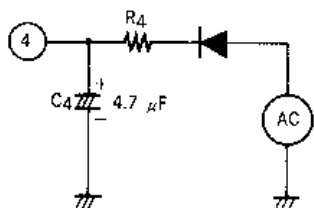
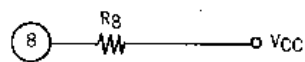
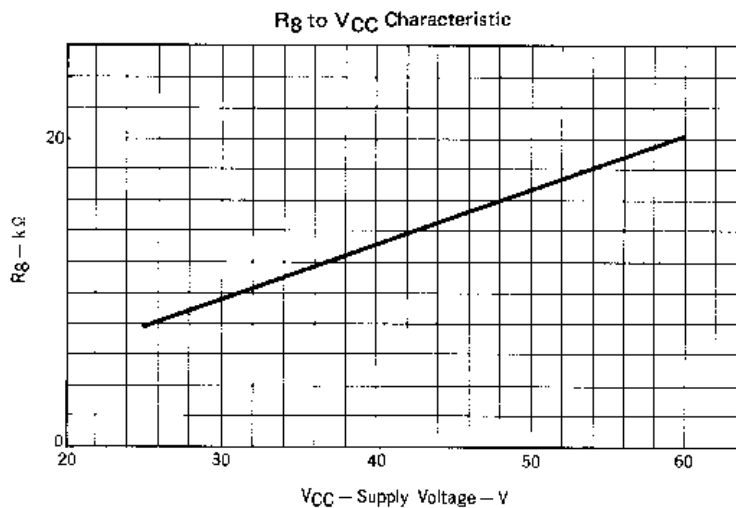

fig. 6 OPTIMUM VALUE OF EXTERNAL RESISTANCE R_8



Example) Use of E-24 series.
 Select $15 k\Omega R_8$ for 45 volts V_{CC} .
 If no resistance of specified value is available,
 choose a resistance which is as close as possible
 to and lower than the value specified by the diagram.

Example) Use of E-24 series.
 Select $24 k\Omega R_4$ for 40 volts r.m.s. V_{AC} .
 If no resistance of specified value is available,
 choose a resistance which is as close as possible
 to and lower than the value specified by the diagram.

TEMPERATURE CHARACTERISTIC

V_g: TON mut, V_{th4}, V_{th+2}, and V_{th1} to T_a Characteristics

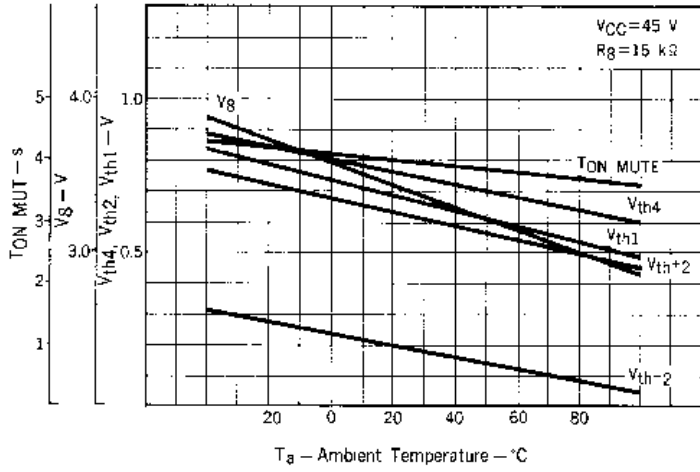

8 PIN PLASTIC SLIM SIP

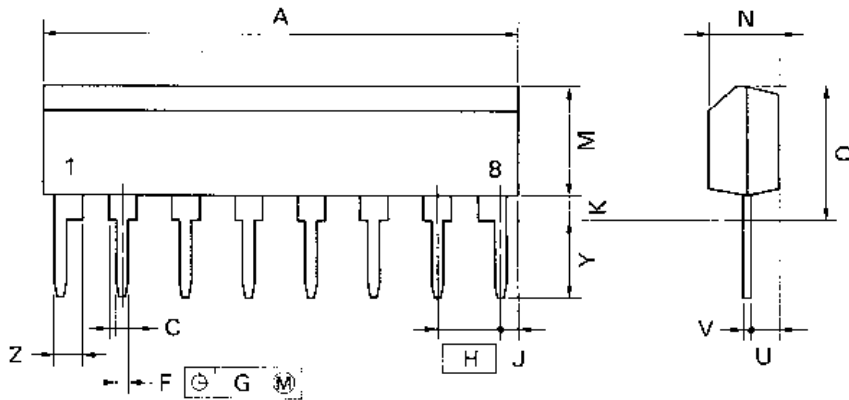

P8HA-254B

NOTE

Each lead centerline is located within 0.25 mm (0.01 inch) of its true position (T.P.) at maximum material condition.

ITEM	MILLIMETERS	INCHES
A	20.32 MAX.	0.8 MAX.
C	1.1 MIN.	0.043 MIN.
F	0.5 ^{+0.1}	0.02 ^{+0.004}
G	0.25	0.01
H	2.54	0.1
J	1.27 MAX.	0.05 MAX.
K	0.51 MIN.	0.02 MIN.
M	5.08 MAX.	0.2 MAX.
N	2.8 ^{+0.2}	0.11 ^{+0.008}
Q	5.75 MAX.	0.227 MAX.
U	1.5 MAX.	0.059 MAX.
V	0.25 ^{+0.08}	0.01 ^{+0.003}
Y	3.2 ^{+0.5}	0.126 ^{+0.02}
Z	1.1 MIN.	0.043 MIN.

[MEMO]

No part of this document may be copied or reproduced in any form or by any means without the prior written consent of NEC Corporation. NEC Corporation assumes no responsibility for any errors which may appear in this document.

NEC Corporation does not assume any liability for infringement of patents, copyrights or other intellectual property rights of third parties by or arising from use of a device described herein or any other liability arising from use of such device. No license, either express, implied or otherwise, is granted under any patents, copyrights or other intellectual property rights of NEC Corporation or others.

The devices listed in this document are not suitable for use in the field where very high reliability is required including, but not limited to, aerospace equipment, submarine cables, nuclear reactor control systems and life support systems. If customers intend to use NEC devices for above applications or those intend to use "Standard" quality grade NEC devices for the application not intended by NEC, please contact our sales people in advance.

Application examples recommended by NEC Corporation

Standard: Data processing and office equipment, Communication equipment (terminal, mobile), Test and Measurement equipment, Audio and Video equipment, Other consumer products, Industrial robots, etc.

Special: Automotive and Transportation equipment, Communication equipment (trunk line), Train and Traffic control devices, Burning control systems, antidisaster systems, anticrime systems etc.