

ArDAM Lite Build Guide

v1.0

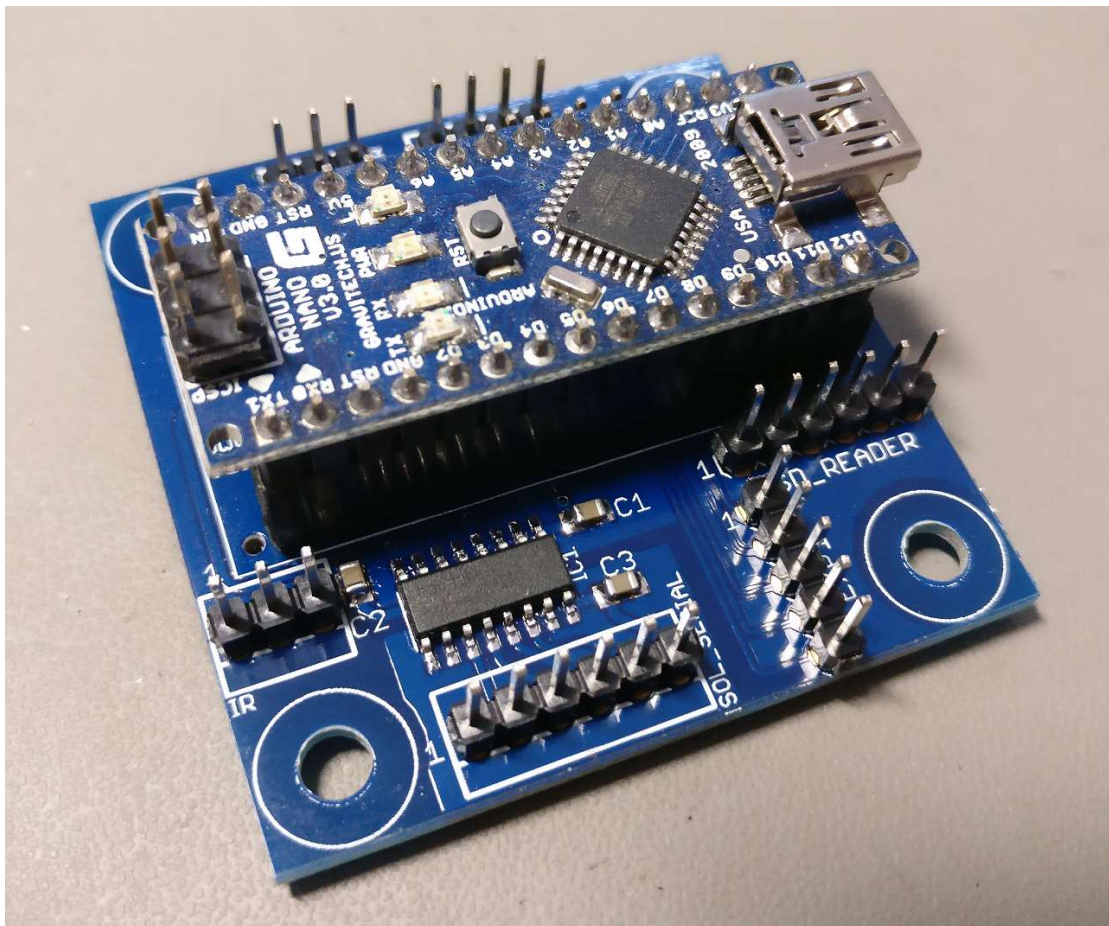

© Dimitris Dimitrakoudis, June 2017

<http://www.dimdim.gr>

This document describes in detail the ArDAM Lite PCB that was offered by me on diyaudio.com's [GB thread](#).

Schematic:

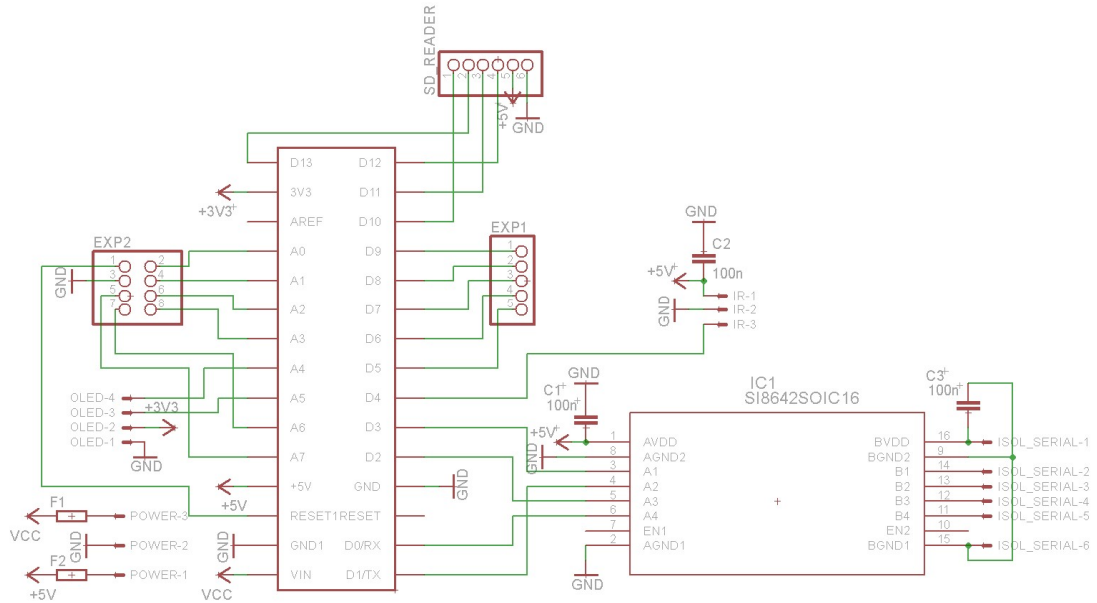

Board Layout:

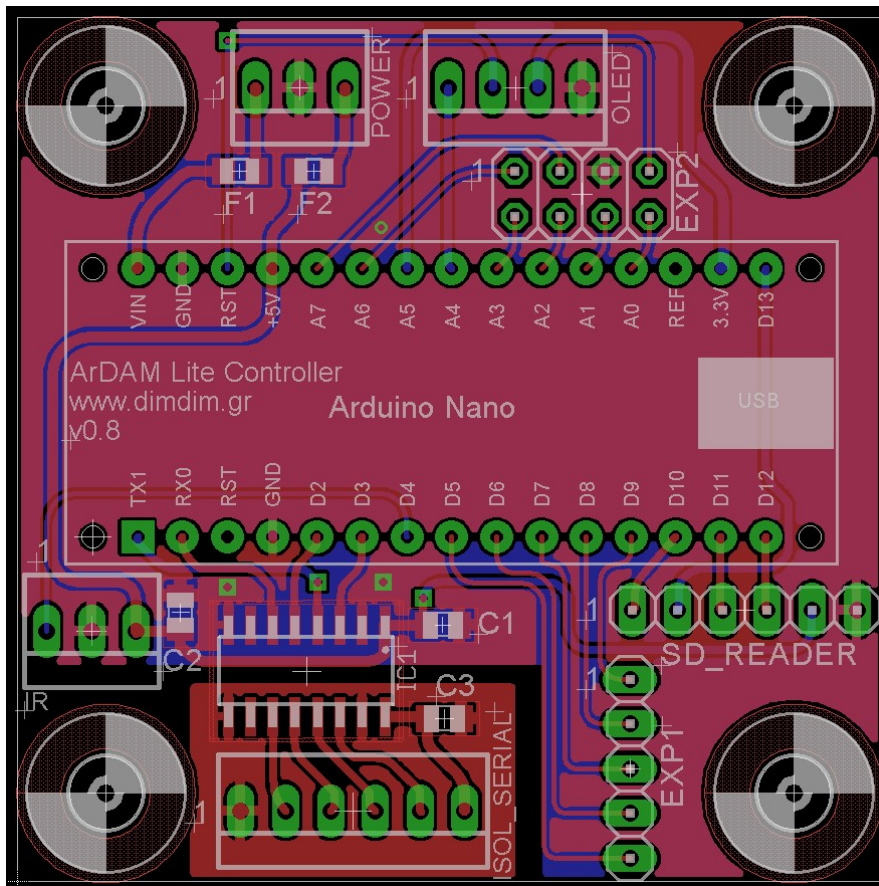

Bill of Materials:

Part	Value	Mouser part no.	Notes
IC1	Si8642BC-B-IS1	634-SI8642BC-B-IS1	
C1, C2, C3	100n 0805	710-885012207072	
FB1, FB2	0805, 2A rated, ~600R impedance	623-2508056017Y2	Value is not critical.
IR Receiver	TSOP4838 38KHz receiver	782-TSOP4838	
ISOL_SERIAL	2.54mm (0.1") pin header, 6 pin		
IR	2.54mm (0.1") pin header, 3 pin		
EXP1	2.54mm (0.1") pin header, 5 pin		
SD_READER	2.54mm (0.1") pin header, 6 pin		
POWER	2.54mm (0.1") pin header, 3 pin		
OLED	2.54mm (0.1") pin header, 4 pin		
EXP2	2.54mm (0.1") pin header, 4x2 pin		
NANO	Arduino NANO		No need to be original.
OLED	0.96" or 1.3" I2C OLED screen		

What this board does is:

- Accommodates the connection of an OLED display.
- Supports an IR receiver.
- Offers up to two (2) galvanically isolated serial ports (one hardware, one software).
- Exposes all of the Arduino Nano's unused I/O pins.

Hardware requirements:

As seen on the BoM, a minimum number of components is necessary. The values of the components are not critical, with the exception of the isolator IC. It should be the exact part number that is specified.

The microcontroller that is used is the Arduino Nano.

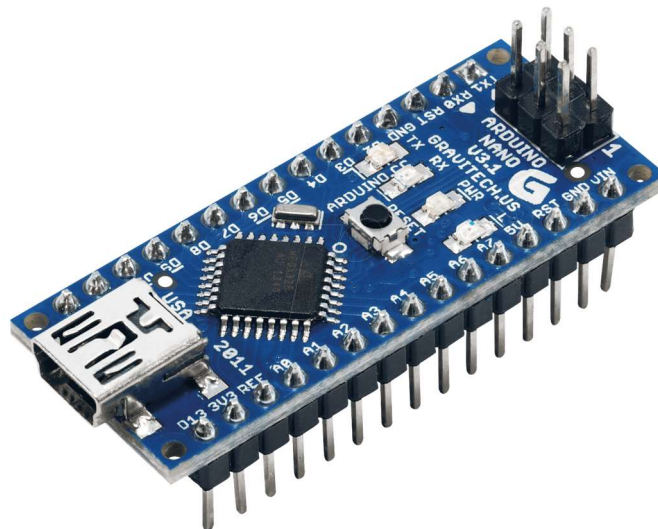

The Arduino Nano is a 5V device, so all of its pins are at 5V levels. Keep that in mind when connecting peripherals (like an SD reader). Some peripherals are designed for 3.3V logic levels.

Software requirements:

The Arduino code that will run on this board can be found here:

<http://www.dimdim.gr/arduino/ardam1021-lite-project/>

The current version of the code supports:

- Powering the DAM on / off (toggle pin D13) by IR remote
- Displaying the signal's sampling rate (to do: support DSD)
- Changing the volume by IR remote
- Changing between sources by IR remote
- Changing filters by IR remote

Remote control:

The IRremote library that is used by my code supports all kinds of remotes so you shouldn't have much trouble finding a suitable one. The current version of the code is capable of decoding all IR signals and sending through the serial port just the IR codes that it does not recognize as valid commands. This way it is easy to discover a working remote and to find out the exact IR code that you should put in the relevant code section:

```
#define POWER_CODE 0xFF48B7 // Code for power on/off
#define SOURCE1_CODE 0xFF827D // Code for source 1
#define SOURCE2_CODE 0xFFB24D // Code for source 2
etc..
```

This functionality is disabled by default in the code to save space and CPU cycles. In order to enable it you should uncomment lines 446 & 447:

```
Serial.print("unexpected value: ");
Serial.println(results.value, HEX);
```

Now when you press a key on a compatible remote you should see its corresponding code on the serial port.

Note on uploading code:

In order to upload code, take the Nano out of the board and connect it to the PC using its USB port. Programming while the Nano is plugged-in to the board may be problematic because the RX & TX lines that are used for serial communication with the PC are also connected to the DAM through the isolator.

Connectivity:

For basic functionality, it is necessary to solder on the following headers:

POWER	
Pin no.	Description
1	Unregulated In
2	Ground
3	Regulated 5V In

Power to the board is supplied by the POWER header. Pin 1 is “Unregulated In”, it must be connected to a 7.5V – 12V power supply. The on-board regulator will drop this down to 5V. Pin 2 is GND. Pin 3 is 5V regulated in. You may power the Nano either by using pins 1(+) & 2 (GND), 3(+) & 2(GND) or by its USB port. **This power supply must be galvanically isolated from the DAM’s power supply(ies).**

OLED	
Pin no.	Description
1	SDA (pin A4 on the Nano)
2	SCL (pin A5 on the Nano)
3	3.3V DC (from the Nano)
4	GND

Compatible OLED displays are both 0.96” and 1.3” I2C OLEDs that can be found on Ebay. These OLED displays are 3.3V devices, so they need +3.3V to function, but their I2C lines are 5V tolerant. Depending on whether you chose the 0.96” or the 1.3” OLED, you will need to comment out the relevant line in the code.

IR	
Pin no.	Description
1	Signal In (pin D4 on the Nano)
2	Ground
3	5V

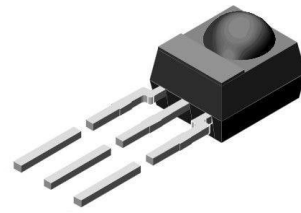

Pin 1 is the leftmost pin, 2 is the center pin, 3 is on the right.

Beware that if you use an IR Receiver other than the TSOP4838, it might have a different pinout.

ISOL_SERIAL	
Pin no.	Description
1	GND (connect to ISO GND at the DAM's J3)
2	RX (pin RXD on the Nano)
3	Input (pin D2 on the Nano)
4	TX (pin TXD on the Nano)
5	Output (pin D3 on the Nano)
6	Vcc (connect to ISO +3.3V at the DAM's J3)

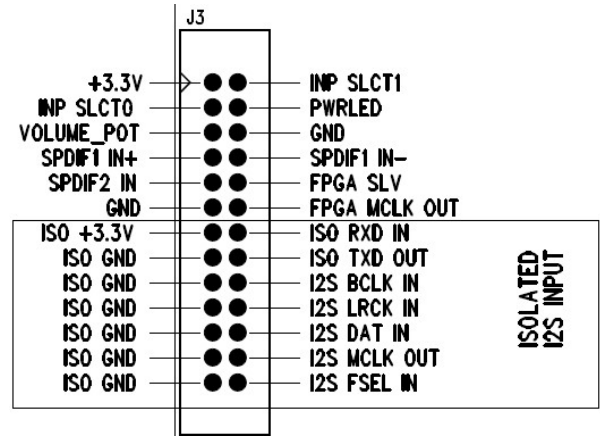

The isolated side may be powered by either 3.3V or 5V, it does not matter. In case of the DAM, it should be 3.3V taken from J3. For proper serial communication, **Pin 2** should be connected to the pin **ISO TXD OUT** and **Pin 4** to **ISO RXD IN**.

Other headers:

EXP1	
Pin no.	Description
1	D9 on the Nano
2	D8 on the Nano
3	D7 on the Nano
4	D6 on the Nano
5	D5 on the Nano

EXP2	
Pin no.	Description
1	A6 on the Nano
2	A3 on the Nano
3	A7 on the Nano
4	A2 on the Nano
5	GND
6	A1 on the Nano
7	RST on the Nano
8	A0 on the Nano

SD_READER	
Pin no.	Description
1	SS (D10 on the Nano)
2	SCK (D13 on the Nano)
3	MOSI (D11 on the Nano)
4	MISO (D12 on the Nano)
5	+5V
6	GND

Revision history:

Date	Version	Notes
05/07/2017	v1.0	